



Компания "LRservice" предлагает оригинальные, не оригинальные запчасти, аксессуары, детали тюнинга для всех моделей Land Rover.

Мы производим техническое обслуживание, ремонт, тюнинг, стайлинг, внедорожную подготовку автомобилей Land Rover.

Осуществляем быстрые розничные или оптовые поставки в регионы России и другие страны.

На нашем сайте www.lrservice.ru, который постоянно пополняется, вы найдете огромное количество информации по автомобилям Land Rover: руководства по эксплуатации, фотографии, Часто Задаваемые Вопросы, Вопрос-Ответ, Форум, каталоги запчастей и многое другое.



BY APPOINTMENT
TO HER MAJESTY THE QUEEN
MANUFACTURERS OF
LAND ROVER VEHICLES
LAND ROVER, WARWICK



BY APPOINTMENT
TO HER MAJESTY THE QUEEN
MANUFACTURERS OF
LAND ROVER VEHICLES
LAND ROVER, WARWICK



BY APPOINTMENT
TO HER MAJESTY THE QUEEN
MANUFACTURERS OF
LAND ROVER VEHICLES
LAND ROVER, WARWICK



BY APPOINTMENT
TO HER MAJESTY THE QUEEN
MANUFACTURERS OF
LAND ROVER VEHICLES
LAND ROVER, WARWICK



FREELANDER

OWNER'S HANDBOOK

Publication Part No. LRL0672ENX - 2nd Edition

© Land Rover 2003

All rights reserved. No part of this publication may be reproduced, stored in a retrieval system or transmitted in any form, electronic, mechanical, recording or other means without prior written permission from Land Rover.



As part of Land Rover environmental policy, this publication is printed on paper made from chlorine free pulp.

Introduction

This handbook covers all derivatives in the Freelander range available at the date of publication and, together with the other publications in the literature pack, provides the information you will need to derive maximum pleasure from owning and driving the vehicle.

For your convenience, the handbook is divided into sections, each dealing with a different aspect of the vehicle. These are listed on the following page and you will find it worthwhile to take a little time to read each one, and get to know your Freelander as soon as you possibly can. The more you understand before you drive, the greater the satisfaction once you are seated behind the steering wheel.

* An asterisk appearing within the text, identifies features or items of equipment that are either optional, or are only fitted to some vehicles in the model range.

IMPORTANT

The specification of each vehicle will vary according to territorial requirements and also from model to model within the vehicle range. Some of the information published in this handbook, therefore, may not apply to your particular vehicle.

Land Rover operates a policy of constant product improvement and therefore reserves the right to change specifications without notice at any time. Whilst every effort is made to ensure complete accuracy of the information in this handbook, no liabilities for inaccuracies or the consequences thereof can be accepted by the manufacturer or the dealer, except in respect of personal injury caused by the negligence of the manufacturer or the dealer.

Contents

Quick Overview

| | |
|--------------------------------------|----|
| FASCIA CONTROLS | 5 |
| INSTRUMENT PANEL | 6 |
| WARNING LIGHTS. | 7 |
| LIGHTS & INDICATORS. | 8 |
| WIPERS & WASHERS | 9 |
| CENTRE CONSOLE SWITCHES - 5 DOOR | 10 |
| CENTRE CONSOLE SWITCHES - 3 DOOR | 11 |
| HEATER CONTROLS | 12 |
| AUDIO SYSTEM CONTROLS | 13 |
| NAVIGATION SYSTEM CONTROLS | 14 |

Filling Station Information

| | |
|------------------------------|----|
| Fuel filler | 15 |
| Opening the bonnet | 16 |
| Tyre pressures. | 16 |

Before You Drive

| | |
|----------------------------|----|
| Before You Drive | 19 |
|----------------------------|----|

Controls & Instruments

| | |
|---------------------------------|----|
| Keys & Handsets | 23 |
| Fascia Controls | 24 |
| Locks & Alarm | 26 |
| Seats | 35 |
| Seat Belts | 40 |
| Child Restraints | 45 |
| Airbag SRS | 47 |
| Steering Column | 51 |
| Instruments | 52 |
| Warning Lights | 55 |
| Lights & Indicators | 58 |
| Wipers & Washers | 61 |
| Horn | 64 |
| Mirrors | 65 |
| Windows | 68 |
| Sunroof | 73 |
| Heating & Ventilation | 75 |
| Interior Equipment | 81 |
| Rear Door | 88 |
| Loadspace Cover | 89 |
| In-Car Telephones | 90 |
| Audio System | 91 |

Driving & Operating

| | |
|----------------------|-----|
| Starting & Driving | 95 |
| Catalytic Converter | 101 |
| Fuel System | 103 |
| Manual Gearbox | 107 |
| Automatic Gearbox | 108 |
| Hill Descent Control | 113 |
| Cruise Control | 116 |
| Brakes | 118 |
| Traction Control | 122 |
| Parking Aid System | 123 |
| Targa Roof | 125 |
| Softback | 127 |
| Hardback | 138 |
| Roof Bars | 142 |
| Taildoor | 145 |
| Load Carrying | 146 |
| Towing | 149 |

Off-Road Driving

| | |
|--------------------|-----|
| Off-Road Driving | 155 |
| Driving Techniques | 159 |

Owner Maintenance

| | |
|-------------------------|-----|
| Maintenance | 167 |
| Bonnet Opening | 171 |
| Engine Compartment | 172 |
| Engine | 175 |
| Cooling System | 176 |
| Brakes | 178 |
| Power Steering | 180 |
| Washers | 181 |
| Wiper Blades | 182 |
| Battery | 183 |
| Tyres | 187 |
| Cleaning & Vehicle Care | 190 |
| Identification Numbers | 195 |
| Parts & Accessories | 197 |

Emergency Information

| | |
|--------------------|-----|
| Wheel Changing | 201 |
| Emergency Starting | 207 |
| Towing The Vehicle | 209 |
| Fuses | 211 |
| Bulb Replacement | 217 |

Technical Data

| | |
|---------------------|-----|
| Lubricants & Fluids | 233 |
| Capacities | 235 |
| Engines | 236 |
| Electrical System | 238 |
| Steering | 239 |
| Wheels & Tyres | 240 |
| Tyre Pressures | 240 |
| Dimensions | 242 |
| Dimensions | 243 |
| Tow Bar Dimensions | 244 |
| Vehicle Weights | 245 |
| Towing Weights | 246 |
| Fuel Consumption | 247 |
| Appendices | 248 |

Quick Overview

FASCIA CONTROLS

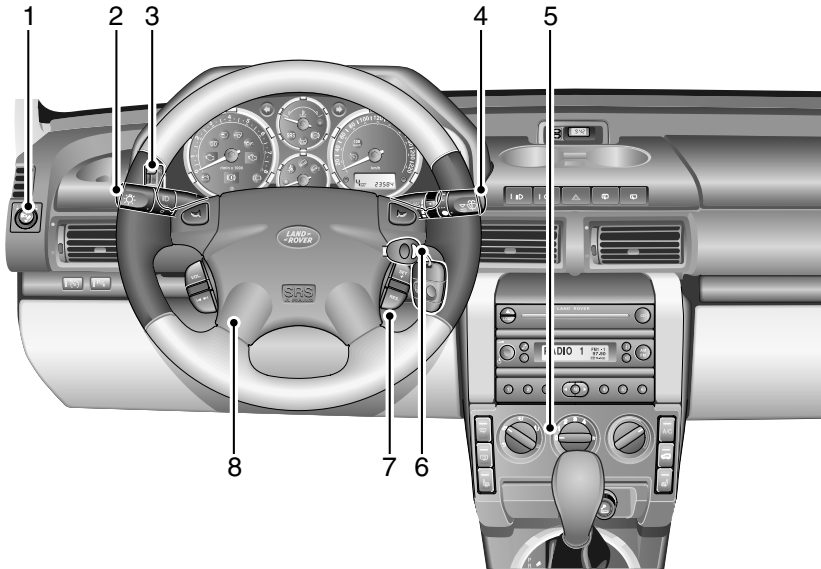

H5139

- | | |
|--|-------------------------------------|
| 1. Exterior mirror control | 5. Heater/Air conditioning controls |
| 2. Lighting and direction indicator controls | 6. Starter switch |
| 3. Headlight levelling control | 7. Cruise control* switches |
| 4. Windscreen wiper/washer controls | 8. Steering column adjustment lever |

NOTE: This is a brief overview of the fascia controls. For further details please refer to 'FASCIA CONTROLS', page 24.

Quick Overview

INSTRUMENT PANEL

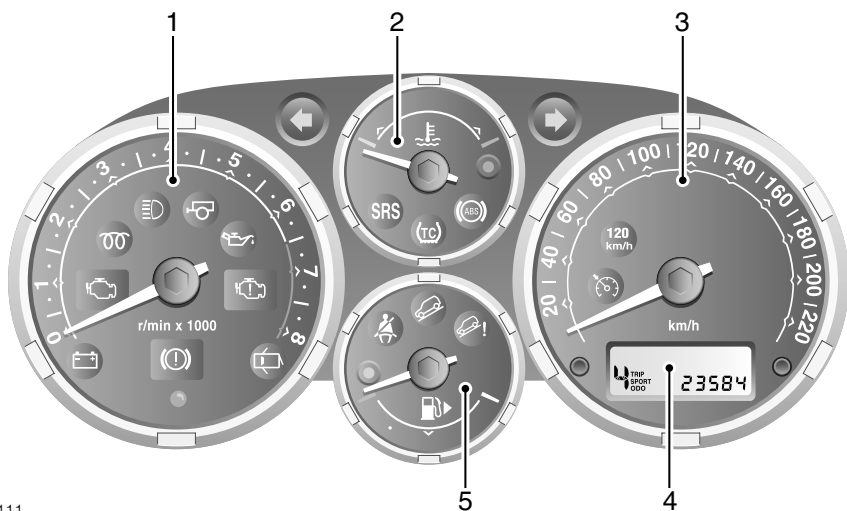

H5111

- 1. Tachometer
- 2. Coolant temperature gauge
- 3. Speedometer
- 4. Digital display
- 5. Fuel gauge

NOTE: This is a brief overview of the instrument panel, for more information, please refer to 'INSTRUMENT PANEL', page 52.

Quick Overview

WARNING LIGHTS

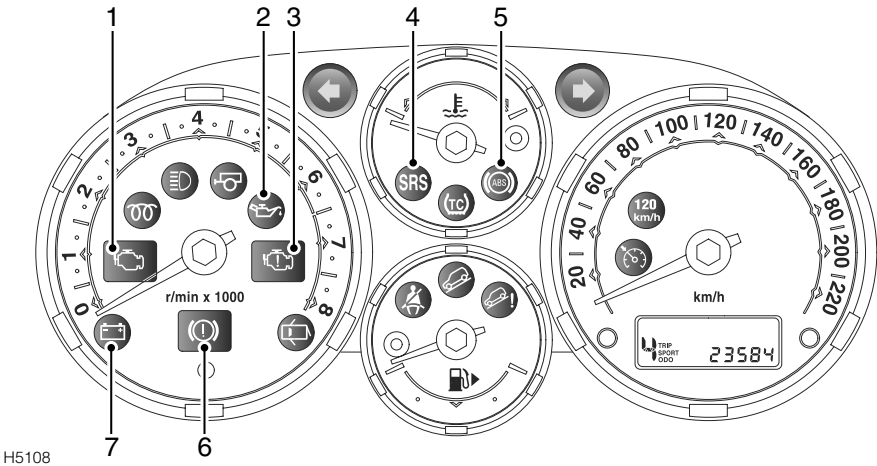

H5108

- | | |
|---|------------------------------------|
| 1. Engine malfunction - M.I.L. (AMBER). | 5. ABS (AMBER). |
| 2. Low oil pressure (RED). | 6. Handbrake & brake system (RED). |
| 3. Engine malfunction (AMBER). | 7. Battery charging (RED). |
| 4. Airbag SRS (RED). | |

NOTE: This is a brief overview of the warning lights, for more information concerning warning light functionality, please refer to 'INSTRUMENT PANEL', page 55.

Quick Overview

LIGHTS & INDICATORS

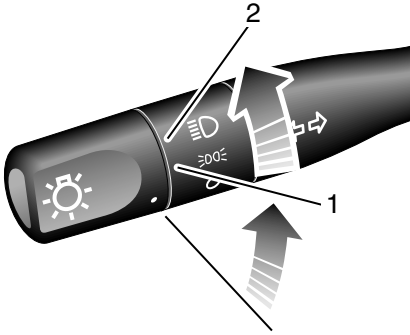

H5094

1. Side, tail and instrument panel lights
2. Headlights

Headlight main and dipped beams

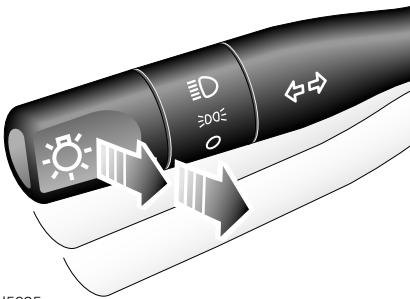

H5095

Pull the lever fully towards the steering wheel to change headlight beams.

Direction indicators

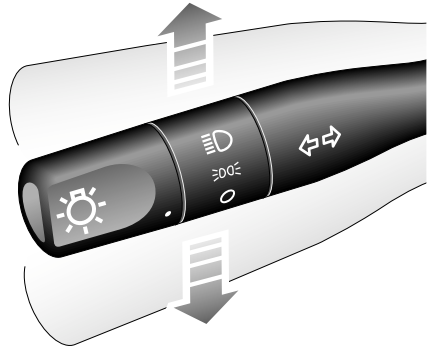

H5093

Move the lever DOWN to indicate a LEFT turn, and UP to indicate a RIGHT turn.

NOTE: For further information concerning operation of the lights, please refer to 'DIRECTION INDICATORS', page 58.

Quick Overview

WIPERS & WASHERS

The wipers and washers will only operate when the starter switch is turned to position 'I' or 'II'.

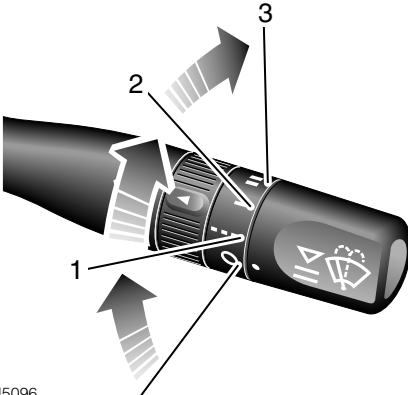

H5096

1. Intermittent wipe
2. Normal speed wipe
3. Fast speed wipe

Single wipe

Pull the lever down and release immediately.

Variable delay (intermittent wipe)

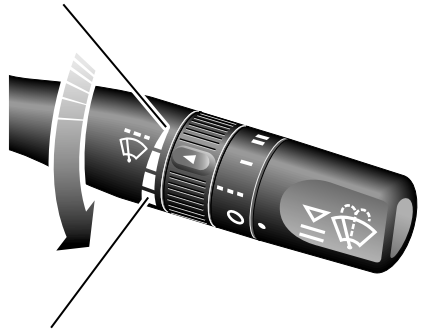

H5098

Rotate the inner switch to vary the delay between wipes.

Windscreen washers

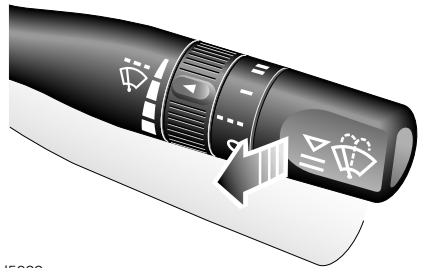

H5099

Pull the lever towards the steering wheel. The windscreen wipers will operate in conjunction with the washers.

NOTE: For further information concerning operation of the wipers and washers, please refer to 'WINDSCREEN WIPERS', page 61 and 'WINDSCREEN WASHERS', page 62.

Quick Overview

CENTRE CONSOLE SWITCHES - 5 DOOR

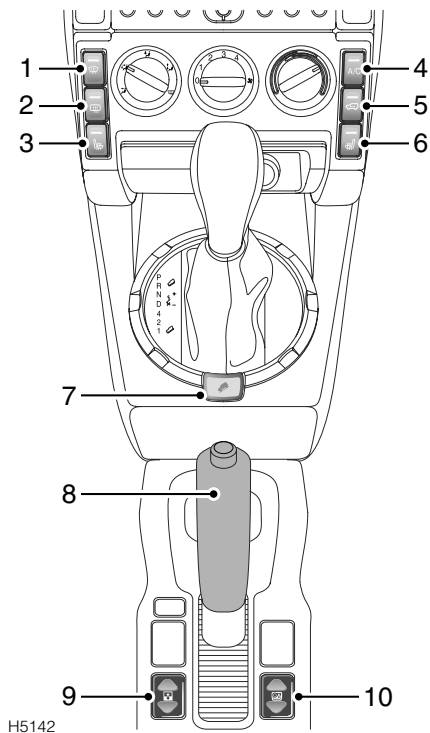

H5142

Automatic model illustrated

- | | |
|-----------------------------|-----------------------------|
| 1. Heated front screen* | 7. Hill Descent Control |
| 2. Heated rear screen | 8. Handbrake |
| 3. Heated driver's seat* | 9. Sunroof* |
| 4. Air conditioning* | 10. Electric taildoor glass |
| 5. Recirculated air supply* | |
| 6. Heated passenger's seat* | |

Quick Overview

CENTRE CONSOLE SWITCHES - 3 DOOR

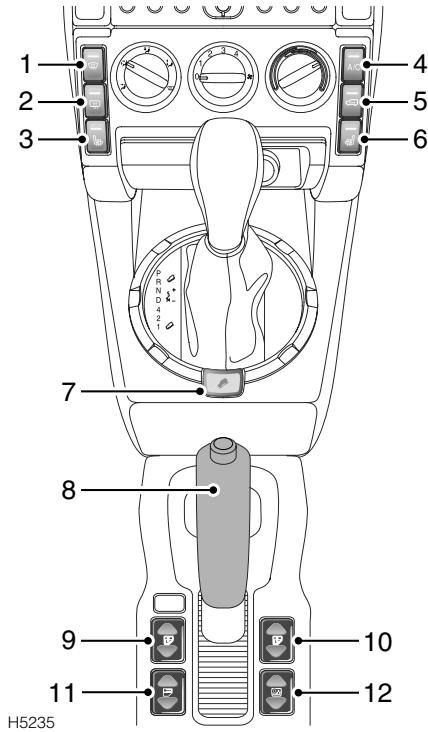

Automatic model illustrated

- | | |
|-----------------------------|--------------------------------|
| 1. Heated front screen* | 7. Hill Descent Control |
| 2. Heated rear screen | 8. Handbrake |
| 3. Heated driver's seat* | 9. Driver's window control |
| 4. Air conditioning* | 10. Passenger's window control |
| 5. Recirculated air supply* | 11. Interior locking switch |
| 6. Heated passenger's seat* | 12. Electric taildoor glass |

Quick Overview

HEATER CONTROLS

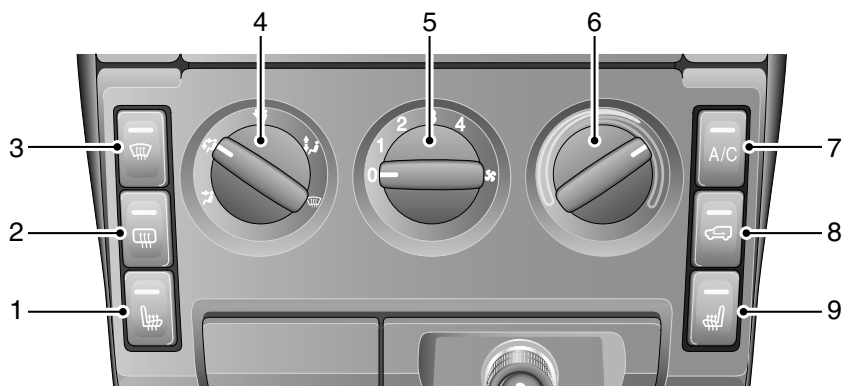

H5063

1 & 9. Heated front seats*

Press to heat the driver's or front passenger seat. Press a second time to switch off.

2. Heated rear window





Press to defrost or demist the rear screen.

3. Heated front screen*

Press to defrost or demist the screen.

4. Air distribution control

Rotate to select air distribution:

-  Air to face vents.
-  Air to face vents and foot outlets.
-  Air to foot outlets.
-  Air to foot outlets and windscreen.
-  All air to windscreen.

5. Air blower control

6. Air temperature control

7. Air conditioning*

8. Air recirculation button*

Press to recirculate air inside the vehicle.

NOTE: For further information concerning operation of the heater controls, please refer to 'HEATER CONTROLS', page 76.

Quick Overview

AUDIO SYSTEM CONTROLS

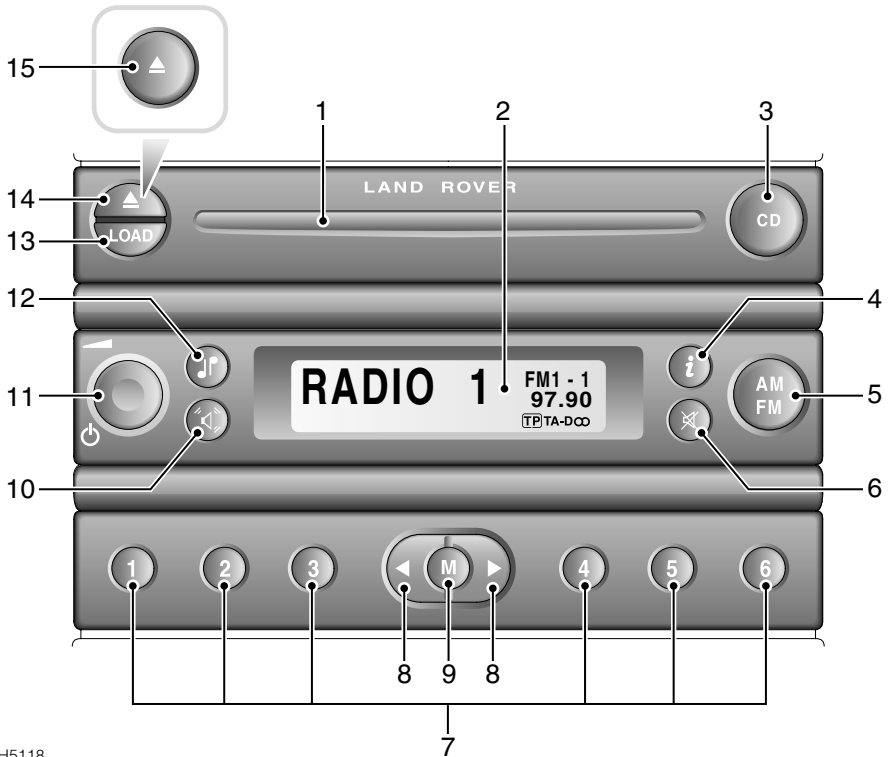

H5118

- | | |
|---------------------------------|---|
| 1. CD compartment | 9. Memory store button |
| 2. Display | 10. Fader and balance control |
| 3. CD mode button | 11. On/off and volume control |
| 4. Traffic and news information | 12. Tone control |
| 5. Waveband selector | 13. CD load button (Multichanger only) |
| 6. Sound mute | 14. CD eject button (Multichanger only) |
| 7. Pre-set/CD buttons | 15. CD eject button |
| 8. Search/CD track controls | |

Quick Overview

NAVIGATION SYSTEM CONTROLS

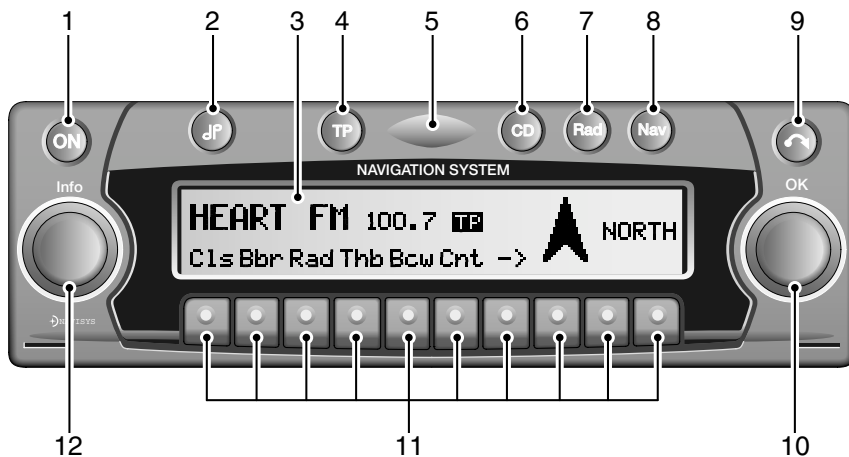

ICE 0223

- | | |
|----------------------|--------------------------------|
| 1. On/off | 7. Radio mode selection |
| 2. Tone | 8. Navigation mode selection |
| 3. Display | 9. Display/CD eject |
| 4. Traffic programme | 10. Right rotary control |
| 5. Security light | 11. Multifunction buttons |
| 6. CD mode selection | 12. Left rotary/volume control |

NOTE: Please refer to your 'In-Car Entertainment' and 'Navigation' handbooks for further details.

NOTE: Some music CD manufacturers are using data encryption to 'copy-protect' their recordings and prevent the production of pirate copies. These CD's differ from the internationally agreed CD audio standard, RedBook, a standard that serves as the operating basis for all CD players and changers.

Copy-protected CD's may not play in your Audio unit or CD changer or may be played subject to various limitations, e.g., sound quality may be impaired.

If you do experience a problem, try the CD in other players before contacting the CD vendor.

Filling Station Information

Fuel filler

The fuel filler is located in the rear right-hand wing.

Insert the key in the lock, turn it anti-clockwise and allow any pressure inside the tank to escape, before removing the cap

NOTE: The key cannot be removed from the filler cap unless the cap is correctly positioned in the filler neck.

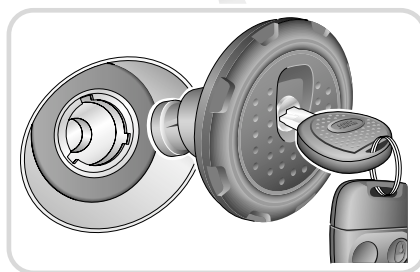
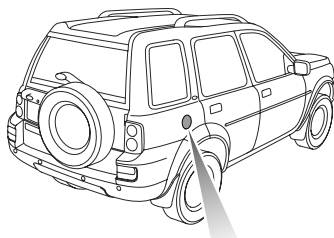

H5115

| Fuel type | |
|-----------------|---|
| Diesel vehicles | To EN590 specification. NOT compatible with Bio-Diesel fuels |
| Petrol vehicles | Unleaded 95RON |

NOTE: For more detailed information, see 'FUEL FILLING', page 104.

Filling Station Information

Opening the bonnet

1. From inside the vehicle, pull the bonnet release handle located on the right hand side of the fascia at knee height.
2. Lift the bonnet safety catch lever and raise bonnet.
3. Support the bonnet in the raised position with the bonnet stay.

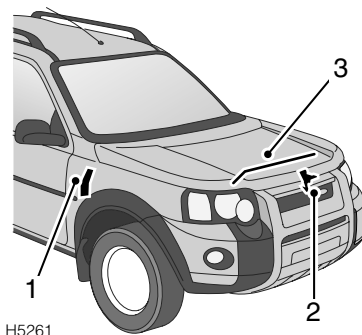

| Engine oil top up | |
|--|--|
| Diesel vehicles | 0W/30, 5W/30, 5W/40, 5W/50, 10W/30, 10W/40 or 10W/60 oil to ACEA: A3 and B3 specification. |
| Petrol vehicles - 1.8 litre & 2.5 litre V6 | 10W/40 oil to ACEA: A2 or A3 specification. |
| Cooling system top up | |
| All vehicles | 50% mix of fresh water and ethylene glycol based anti freeze (containing no methanol). |

NOTE: For more detailed information, see 'BONNET OPENING', page 171.

Tyre pressures

Air pressure naturally increases in warm tyres (after the vehicle has been driven for a while). If you have to check warm tyres, you should expect the pressures to have increased between 30 and 40 kPa. In this circumstance, NEVER let air out of the tyres in order to match the recommended pressures.

| Loading condition | | Pressure - kPa |
|---|--------------|----------------|
| All driving conditions (all tyre sizes) | Front & Rear | 211 |

NOTE: For more detailed information, see 'TYRE PRESSURES', page 241.

Before You Drive

| | |
|---|----|
| SYMBOLS USED | 19 |
| WARNINGS IN THIS HANDBOOK | 19 |
| SERVICE PORTFOLIO | 19 |
| SECURITY CARD | 19 |
| BEFORE YOU DRIVE | 19 |
| WARNING LABELS ATTACHED TO THE VEHICLE IN AN EMERGENCY | 20 |





Before You Drive

SYMBOLS USED

The following symbols used within the handbook call your attention to specific types of information.



This recycling symbol identifies those items that must be disposed of safely in order to prevent unnecessary damage to the environment.



This symbol identifies those features that can be adjusted or disabled/enabled by a Land Rover Dealer/Authorised Repairer.

WARNINGS IN THIS HANDBOOK

WARNING

Safety warnings are included in this handbook. These indicate either a procedure which must be followed precisely, or information that should be considered with great care in order to avoid the possibility of personal injury or serious damage to the vehicle.

SERVICE PORTFOLIO

The Service Portfolio book included in your literature pack contains important vehicle identification information, details of your entitlement under the terms of the Land Rover Warranty, as well as useful consumer advice.

Most important of all, however, is the section on maintenance. This outlines the servicing requirements for your vehicle and also includes the service record slips, which the Dealer/Authorised Repairer should sign and stamp to certify that the routine services have been carried out at the recommended intervals.

SECURITY CARD

The security card, supplied with the literature pack, contains important emergency information. It is ESSENTIAL that you keep the card safe from theft and ensure that it is passed to the new owner if you sell the vehicle.

- **Locking wheel nut number:** If your vehicle has locking wheel nuts, you will have been provided with a special wheel nut socket to remove them. You will need to quote this number to obtain a replacement socket.
- **VIN (vehicle identification number):** This identity number is unique to your vehicle and is essential proof of its specification. The number can also be found in various locations around the vehicle (see 'VEHICLE IDENTIFICATION NUMBER', page 196).
- **Radio security code number:** This unique code must be entered into the radio whenever the power supply has been disconnected. Without this code, the radio unit will not operate (see 'Security code' in the 'In-Car Entertainment' book).

WARNING

Never leave the security card inside the vehicle when it is unattended.

BEFORE YOU DRIVE

WARNING

Your vehicle has a higher ground clearance and, hence, a higher centre of gravity than ordinary passenger cars. This will result in different handling characteristics. Inexperienced drivers should take additional care, particularly in off-road driving situations and when performing abrupt manoeuvres on unstable surfaces.

Before You Drive

WARNING LABELS ATTACHED TO THE VEHICLE



Warning labels attached to your vehicle bearing this symbol mean: DO NOT touch or adjust components until you have read the relevant instructions in the handbook.



Warning labels showing this symbol indicate that the ignition system utilises very high voltages. DO NOT touch any ignition components while the starter switch is turned on!



IN AN EMERGENCY

IMPORTANT

Remember the breakdown safety code

If a breakdown occurs while travelling:

- Wherever possible, consistent with road safety and traffic conditions, the vehicle should be moved off the main thoroughfare, preferably into a lay-by. If a breakdown occurs on a motorway, pull well over to the inside of the hard shoulder.
- Switch on hazard lights.
- If possible, position a warning triangle or a flashing amber light at an appropriate distance from the vehicle to warn other traffic of the breakdown, (note the legal requirements of some countries).
- Consider evacuating passengers through nearside doors onto the verge as a precaution in case your vehicle is accidentally struck by other traffic.

Controls & Instruments

Keys & Handsets

| | |
|-----------------------------|----|
| KEYS AND HANDSETS | 23 |
|-----------------------------|----|

Fascia Controls

| | |
|---------------------------|----|
| FASCIA CONTROLS | 24 |
|---------------------------|----|

Locks & Alarm

| | |
|---|----|
| STEERING COLUMN LOCK | 26 |
| ALARM SYSTEM | 26 |
| LOCKING THE VEHICLE AND ARMING THE ALARM | 26 |
| CHILD-PROOF LOCKS | 32 |
| ENGINE IMMOBILISATION | 32 |
| DOOR LOCKING CUT-OFF SWITCH | 33 |
| REMOTE HANDSET | 34 |

Seats

| | |
|-----------------------|----|
| FRONT SEATS | 35 |
|-----------------------|----|

Seat Belts

| | |
|------------------------------------|----|
| SEAT BELT SAFETY | 40 |
| PREGNANT WOMEN | 41 |
| SEAT BELTS | 41 |
| SEAT BELT PRE-TENSIONERS | 43 |
| CARING FOR SEAT BELTS | 44 |

Child Restraints

| | |
|------------------------------|----|
| CHILD SAFETY SEATS | 45 |
|------------------------------|----|

Airbag SRS

| | |
|------------------------------------|----|
| AIRBAG SRS | 47 |
| HOW THE AIRBAG SRS WORKS | 48 |
| SERVICE INFORMATION | 50 |

Steering Column

| | |
|--------------------------------------|----|
| STEERING COLUMN ADJUSTMENT | 51 |
|--------------------------------------|----|

Instruments

| | |
|----------------------------|----|
| INSTRUMENT PANEL | 52 |
|----------------------------|----|

Warning Lights

| | |
|----------------------------|----|
| INSTRUMENT PANEL | 55 |
|----------------------------|----|

Lights & Indicators

| | |
|--------------------------------|----|
| DIRECTION INDICATORS | 58 |
| LIGHTS | 58 |



| | |
|-----------------------------|----|
| FOG LIGHTS | 60 |
| HAZARD WARNING LIGHTS | 60 |

Wipers & Washers

| | |
|------------------------------------|----|
| OPERATING | 61 |
| WINDSCREEN WIPERS | 61 |
| WINDSCREEN WASHERS | 62 |
| REAR SCREEN WIPER AND WASHER | 63 |

Horn

| | |
|------------|----|
| HORN | 64 |
|------------|----|

Mirrors

| | |
|------------------------|----|
| EXTERIOR MIRRORS | 65 |
| INTERIOR MIRROR | 66 |
| VANITY MIRROR | 67 |

Windows

| | |
|--|----|
| ELECTRIC WINDOW CONTROLS | 68 |
| ELECTRIC TAILDOOR GLASS | 71 |
| REAR VENTILATOR WINDOWS (3-door models) | 72 |

Sunroof

| | |
|------------------------|----|
| ELECTRIC SUNROOF | 73 |
|------------------------|----|

Heating & Ventilation

| | |
|-------------------------|----|
| VENTILATION | 75 |
| HEATER CONTROLS | 76 |
| USING YOUR HEATER | 78 |
| FACE LEVEL VENTS | 79 |
| AIR CONDITIONING | 80 |

Interior Equipment

| | |
|--|----|
| COURTESY & MAP READING LIGHTS (5-door models) | 81 |
| COURTESY LIGHT (3-door models) | 81 |
| LUGGAGE COMPARTMENT LIGHT | 81 |
| CLOCK | 82 |
| GLOVEBOX | 82 |
| DRIVER'S STORAGE AREA | 83 |
| DRINKS STOWAGE | 83 |
| CUP HOLDERS | 84 |
| SUN VISOR | 85 |
| SUNGLASSES POCKET (3-door models) | 85 |
| ASHTRAY | 86 |
| CIGAR LIGHTER | 86 |
| AUXILIARY POWER SOCKET | 87 |

Rear Door

| | |
|-----------------|----|
| REAR DOOR | 88 |
|-----------------|----|

Loadspace Cover

| | |
|-----------------------|----|
| LOADSPACE COVER | 89 |
|-----------------------|----|

In-Car Telephones

| | |
|-------------------------|----|
| IN-CAR TELEPHONES | 90 |
|-------------------------|----|

Audio System

| | |
|-----------------------------|----|
| AUDIO EQUIPMENT | 91 |
| RADIO AERIAL | 91 |
| REMOTE AUDIO CONTROLS | 91 |

Keys & Handsets

KEYS AND HANDSETS

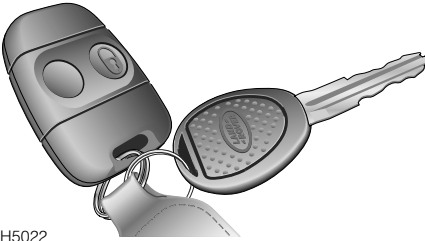

H5022

You have been supplied with a pair of identical keys and two remote control handsets.

WARNING

Keep the spare set in a safe place - NOT IN THE VEHICLE!

Your keys

The keys supplied with your vehicle are programmed to the vehicle's security system - they **CANNOT** be reprogrammed and the engine cannot be started without a valid programmed key. If a key is lost or broken, a replacement can be ordered only from a Land Rover Dealer/Authorised Repairer.

NOTE: *Land Rover Dealers/Authorised Repairers do not stock spare keys, time has to be allowed for replacements to be programmed to your security system and then delivered to the dealer.*

If you lose a key, contact your Land Rover Dealer/Authorised Repairer; a key reported lost will be deactivated. If the key is later recovered, your Land Rover Dealer/Authorised Repairer can have it reactivated.

Fascia Controls

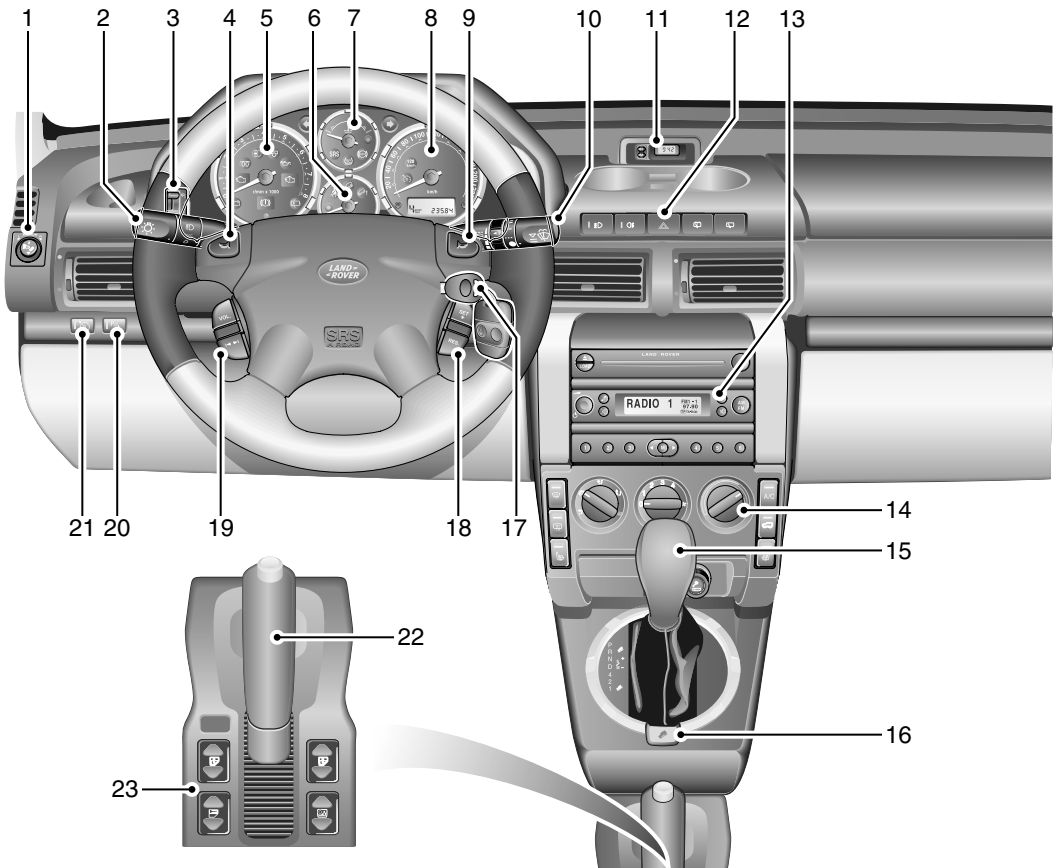

Fascia Controls

1. Exterior mirror control
2. Lighting and direction indicator controls
3. Headlight levelling control
4. Horn
5. Tachometer
6. Fuel gauge
7. Coolant temperature gauge
8. Speedometer
9. Horn
10. Windscreen wiper/washer controls
11. Clock display
12. Hazard warning switch
13. Audio system
14. Heater/Air conditioning controls
15. Gear lever
16. Hill descent control
17. Starter switch
18. Remote cruise control* switches
19. Remote audio controls*
20. Parking aid system switch
21. Cruise control master switch*
22. Handbrake
23. Centre console switches (3 Door shown)

NOTE: *The precise specification and location of the controls may vary according to territorial requirements and from model to model within the vehicle range.*

Locks & Alarm

STEERING COLUMN LOCK

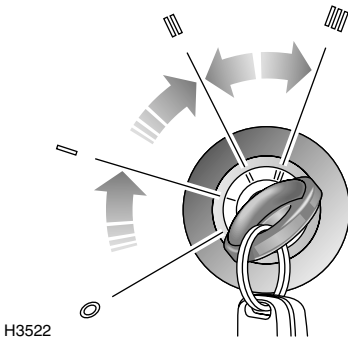

To unlock the steering column

Insert the key FULLY and turn the starter switch to position 'I'. A small movement of the steering wheel may be necessary to disengage the steering lock while turning the switch.

To lock the steering column

Turn the key to position '0' and withdraw it from the starter switch. Turn the steering wheel slightly until the lock engages.

WARNING

Once the steering lock has engaged, it is impossible to steer the vehicle. DO NOT remove the key or turn the starter switch to position '0' while the vehicle is in motion.

ALARM SYSTEM

Your vehicle is fitted with a sophisticated electronic anti-theft alarm and engine immobilisation system. In order to ensure maximum security and minimum inconvenience, you are strongly advised to gain a full understanding of the alarm system, by thoroughly reading this section of the handbook.

LOCKING THE VEHICLE AND ARMING THE ALARM

Before locking the vehicle and arming the alarm, ensure that all doors (including taildoor), windows, sunroof and bonnet apertures are securely closed.

There are three methods for securing your vehicle:

- 'Superlocking' using the handset - (recommended high security method).
- 'Superlocking' using the key.
- Locking using the key.

IMPORTANT

- If passengers or animals are to be left inside, DO NOT lock the vehicle using the handset - movement inside the vehicle may activate interior space protection*, causing the alarm to sound.
- FOR MAXIMUM SECURITY ALWAYS SUPERLOCK THE VEHICLE USING THE REMOTE HANDSET

Locks & Alarm

Using the remote handset

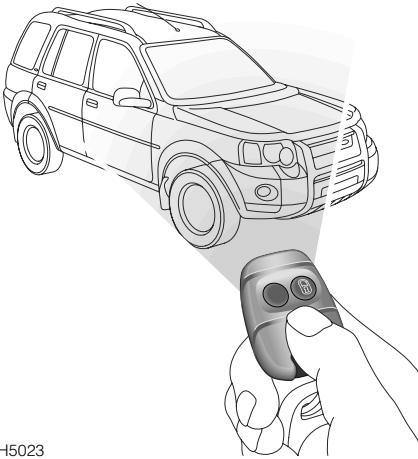

H5023

While it is not necessary to point the handset at the vehicle, the handset must be within range of the vehicle when a button is pressed. Note that the operating range may vary depending upon handset battery condition and may sometimes be limited by physical and geographical factors beyond your control. From a security point of view, it may not be wise to unlock unless you are in close proximity to the vehicle.

Locking

With the remote handset:

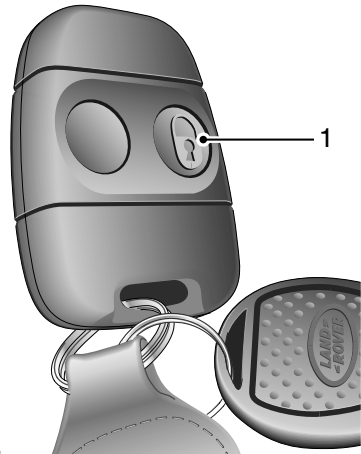

H5024

Press the lock (padlock symbol (1)) button once. Each time the vehicle is locked using the handset, a coded signal is transmitted to a receiver inside the vehicle, which activates the following security features:

- the central door locking system (all the door locks are activated).
- 'Superlocking' - the door locks cannot be operated from inside the vehicle.
- the perimeter alarm (protects the door, taildoor, and bonnet apertures).
- interior space protection*.

If the doors lock correctly, the direction indicator lights flash three times to confirm that the vehicle is secure and the anti-theft alarm indicator light (in the instrument panel) will start to flash rapidly.

Locks & Alarm

Once armed, the alarm will sound if any door is opened, or if the soft-back is raised or hard-back removed or if (after a checking period of 15 seconds) any movement is detected inside the passenger compartment (see '*Interior space protection**', page 31).

With the key:

Insert the key and turn towards the rear of the vehicle. Turning the key ONCE activates the following:

- all doors locked (not superlocked)
- perimeter alarm activated (protects the doors, bonnet and taildoor)

NOTE: *Interior space protection** is not activated!

Turning the key TWICE within 1 second activates, in addition to the above:

- Superlocking

If the doors lock correctly, the direction indicators flash three times to confirm that the vehicle is secure and the anti-theft alarm indicator light (in the instrument panel) will start to flash rapidly.

NOTE: *The engine will automatically be immobilised after the starter switch has been turned off.*

Superlocking

Provided all the doors are fully closed, the Superlocking feature is activated automatically whenever the vehicle is locked using the remote handset. Superlocking immobilises the interior door handles, thereby preventing an intruder from gaining entry by smashing a window and reaching inside the vehicle to operate the door handles.

WARNING

For safety, NEVER use Superlocking if passengers are to remain inside the vehicle - in an emergency they would not be able to escape.

Mislock

If one of the doors, taildoor or bonnet are not properly closed when the alarm is armed, a mislock occurs (the horn will sound a warning). The alarm will still be armed and the engine immobilised, but the open aperture will not be protected and, unless it is the bonnet that has been left open, interior space protection* will not have been activated. If the appropriate aperture is then closed, the alarm will fully arm without the need to press the lock button again unless the driver's door is open, in which case the alarm will be fully armed by pressing the lock button again.

If the taildoor glass is left open when the alarm is armed, the horn will sound as a reminder, but the vehicle will be locked and alarmed as normal. The taildoor glass can be closed from outside the vehicle using the starter key in the taildoor (see '*Raising and lowering*', page 71).

Locks & Alarm

Anti-theft alarm indicator light

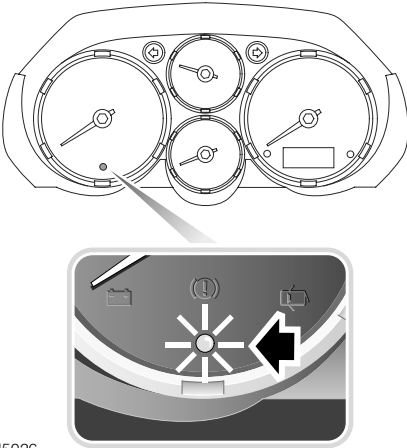

H5026

After locking, the RED indicator light on the instrument panel flashes rapidly while the alarm is arming itself.

After approximately 10 seconds, the indicator light adjusts to a slower frequency, and continues to flash as an anti-theft deterrent until the alarm is disarmed.

Unlocking

With the remote handset:

If your vehicle has been configured with the Single Point Entry security feature, and was locked with the handset, the handset unlocks the vehicle in two stages:

- Press the unlock (no padlock) button once to disarm the alarm and unlock the driver's door only (see 'Single point entry', page 29).
- Press the unlock button twice to disarm the alarm and unlock ALL the doors.

If your vehicle has not been configured with Single Point Entry, all the doors will unlock at the first press. In either case, the direction indicators flash once and the interior lights illuminate.

With the key:

Turn the key towards the front of the vehicle. The alarm will be fully disarmed. To remobilise the engine, the key must be inserted into the starter switch.

If the alarm sounds

If the alarm is triggered, it will sound for approximately 30 seconds before switching itself off and can be triggered up to ten times in total before needing to be reset.

To silence the alarm, press either handset button, or operate the door locks using the key in the driver's door.

Single point entry

This is a personal security feature, which enables the driver's door only to be unlocked, leaving the other doors in a locked state. It can be operated by the remote handset as follows:

Press the unlock button once to unlock the driver's door, press a second time to unlock the remaining doors and taildoor.



Single point entry can be disabled by a Land Rover Dealer/Authorised Repairer.

Locks & Alarm

Interior locking switch - 5 door vehicles

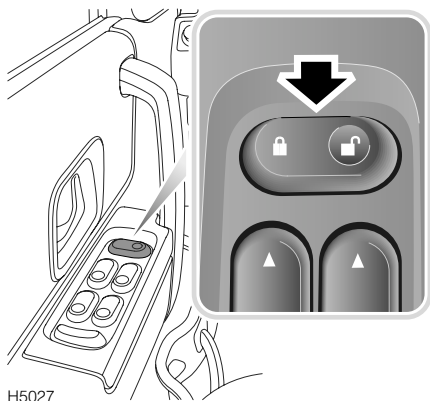

H5027

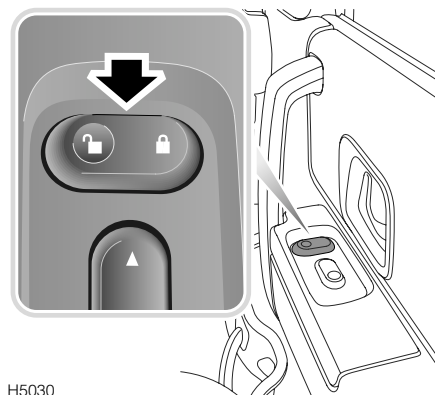

H5030

This is a personal security feature which allows the driver (or passenger) to lock (or unlock) all the doors from inside the vehicle (while driving or with the vehicle stationary). Press the padlock symbol part of the switch to lock (the alarm will not be armed), and the unlocked padlock symbol to unlock.

NOTE: If interior locking has been activated, pull the interior door handle once to unlock, and twice to open the door.

Interior locking switch - 3 door vehicles

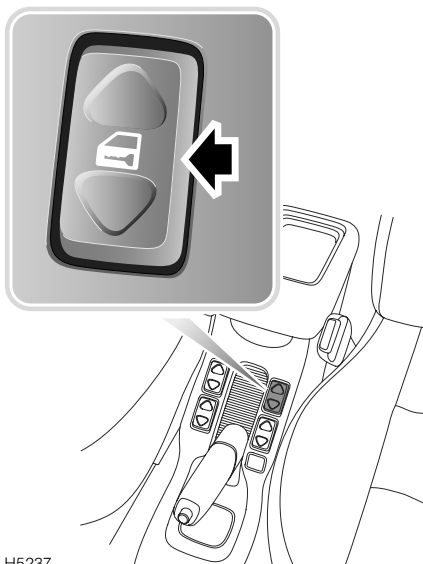

H5237

This is a personal security feature which allows the driver (or passenger) to lock (or unlock) all the doors from inside the vehicle (while driving or with the vehicle stationary). Press the lower part of the switch to lock (the alarm will not be armed), and the upper part to unlock.

NOTE: If interior locking has been activated, pull the interior door handle once to unlock, and twice to open the door.

Locks & Alarm

Door handles and door sill locking buttons

From inside the vehicle, each door can be individually locked by depressing (arrowed in illustration) the appropriate door sill button. However, doors cannot be unlocked by raising the sill button.

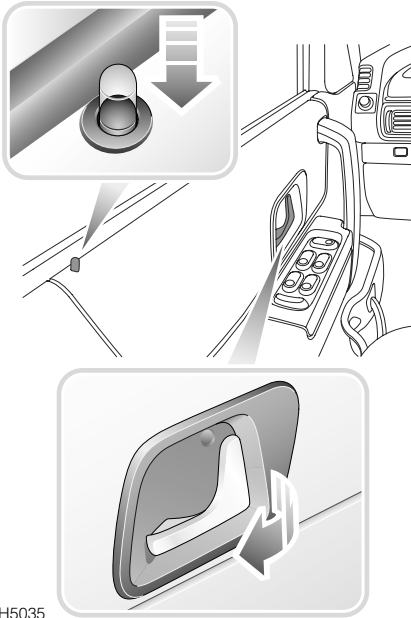

H5035

Use the door handles to unlock, as follows:

- First operation of the door handle unlocks the door.
- Second operation of the door handle opens the door.

NOTE: The door handles will not open the doors if the vehicle has been superlocked (see 'Superlocking', page 28)

Interior space protection*

Interior space protection is designed to protect the interior of the vehicle from intrusion (entry by a thief through a smashed window, for example). A sensor inside the vehicle monitors the interior space and activates the alarm if movement is detected in the passenger compartment.

Using the handset:

Interior space protection is activated automatically whenever the remote handset is used to set the alarm.

Key operation:

Using the key to lock the vehicle will NOT activate interior space protection.

WARNING

Never activate interior space protection if passengers or animals are to be left inside the vehicle - any movement will activate the alarm.

Locks & Alarm

CHILD-PROOF LOCKS



H5029

On 5-door models, move the lever on the rear doors down (arrowed in illustration) to engage.

With the child-proof locks engaged, the rear doors cannot be opened from inside the vehicle, thereby avoiding the risk of a door being opened accidentally.

WARNING

NEVER leave children unsupervised in the vehicle.

ENGINE IMMOBILISATION

Engine immobilisation is an important aspect of the security system and is designed to safeguard the vehicle from theft. Engine immobilisation prevents the engine from being started unless a valid key is inserted into the starter switch and occurs automatically.

The engine is re-mobilised by a signal to the starter switch transmitted from a transponder contained within the key head. This occurs automatically whenever a valid key is inserted into the starter switch and turned to position 'I'.

WARNING

DO NOT keep more than one starter key or keys from other vehicles on the same key ring, because the engine may not re-mobilise automatically.

Locks & Alarm

DOOR LOCKING CUT-OFF SWITCH

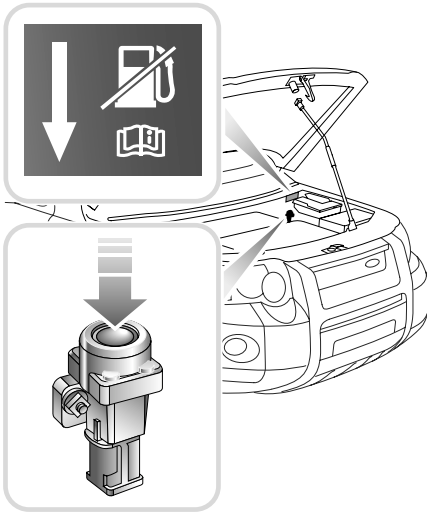

H5033

In the event of an accident or sudden impact, an inertia switch operates when the starter switch is in position 'II', preventing the doors from centrally locking (or, if the doors are already locked, unlocks them). If this occurs, central locking will be inhibited until the driver's door has been opened and closed, and the inertia switch is reset.

The inertia switch is located inside the engine compartment on the left hand side, beneath and to the rear of, the engine compartment fuse box. The switch must be reset before the engine can be restarted. Reset the switch by pressing the rubber top (arrowed in illustration).

On petrol models, this will also reset the fuel system, see 'FUEL CUT-OFF SWITCH (Petrol engine vehicles only)', page 106).

WARNING

Always check for fuel leaks before resetting the switch. Activating the switch when the fuel system has been damaged will cause additional fuel leakage, increasing the risk of fire or personal injury.

Locks & Alarm

REMOTE HANDSET

WARNING

The handset contains delicate electronic circuits and must be protected from impact and water damage, high temperatures and humidity, direct sunlight and the effects of solvents, waxes and abrasive cleaners.

The battery should last for approximately three years dependent upon use. When the battery needs replacing, it will be apparent from the following symptoms:

- A gradual deterioration in range and performance.
- The alarm buzzer and the anti-theft alarm indicator light will double bleep/flash every second, for ten seconds, after the alarm is disarmed and driver's door opened.

It is recommended that you fit a Land Rover YWX10003L or a Panasonic CR2032 replacement battery (available from a Land Rover Dealer/Authorised Repairer).

Battery replacement

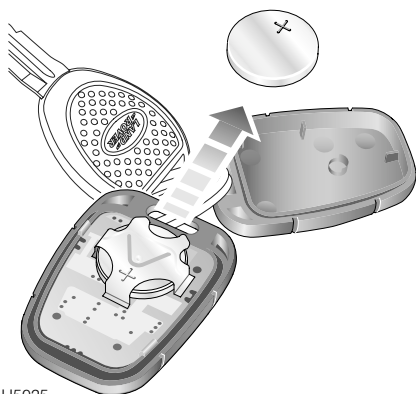

H5025

1. Carefully prise the handset apart, start from the keyring end using a small coin or screwdriver. Avoid damaging the seal between the two halves of the case and DO NOT allow dirt or moisture to get inside the handset.
2. Slide the battery out of its clip, taking care to avoid touching the circuit board or the contact surfaces of the clip.
3. Press and hold each button in turn for at least five seconds (this will drain any residual power from the handset).
4. Fit the new battery, ensuring that correct polarity is maintained ('+' side facing up). Finger marks will adversely affect battery life; if possible, avoid touching the flat surfaces of the battery and wipe them clean before fitting.
5. Press the two halves of the handset firmly together and ensure that both halves are fully joined to prevent dirt or moisture from entering the handset.
6. Resynchronise the handset.

The handset is now ready for use.

Handset resynchronisation

If the handset fails to lock or unlock the car, this may be because the coded signal transmitted by the handset, and the signal expected by the alarm control unit are no longer synchronised.

To resynchronise the handset, operate either button of the handset at least five times in quick succession (in close proximity to the vehicle).

Seats

FRONT SEATS

WARNING

To avoid the risk of loss of control and personal injury, DO NOT adjust the driver's seat or head restraint while the vehicle is in motion.

DO NOT travel with the seat backs reclined steeply rearwards. Optimum benefit is obtained from the seat belt with the seat back reclined to a maximum 30 degrees from the upright (vertical) position.

SITTING CORRECTLY

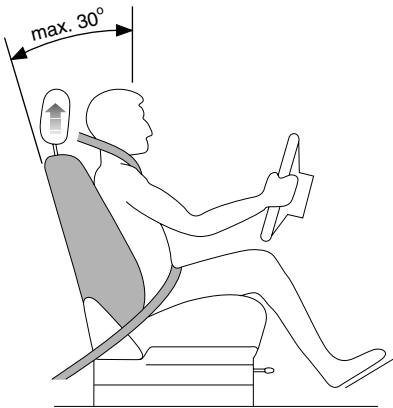

H4767

The seats, head restraints, seat belts and airbags all contribute to the protection of the occupants. Optimal use of these components will give you more protection. Therefore, observe the following points:

- Sit in the most upright position with the base of your spine as far back as possible and the backrest not reclined more than 30 degrees.

- Adjust the head restraints so that the top of the head restraint is level with the upper portion of the head.
- Do not move the front seat too close to the instrument panel. The driver should hold the steering wheel with slightly bent arms. The legs should also be slightly bent so that the pedals can be pressed to the floor.
- The seat belt should rest in the centre of the shoulder. The lap part should fit tightly across the hips and not on the stomach.

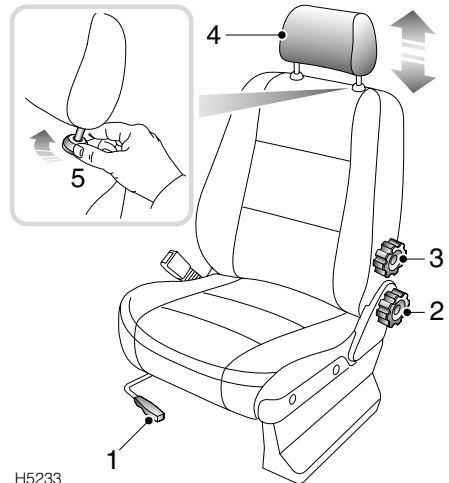

H5233

Forward/backward adjustment

Lift the lever (1) and slide the seat into position. Make sure that the seat is locked in position before driving.

Backrest adjustment

Rotate the handwheel (2) to adjust.

Lumbar support adjustment (Driver's seat only)

Rotate the handwheel (3) to increase or decrease support to the lumbar region of the back.

Seats

Head restraint adjustment

Raise or lower the restraint (4) until the top of the cushion is level with the top of the head.

WARNING

Head restraints are designed to support the back of the head (NOT THE NECK), and to restrain rearward movement of the head in the event of a collision. The restraint must be positioned level with the head to be effective.

Head restraint removal

Turn the right hand mounting (5) a quarter turn anti-clockwise and pull the restraint upwards.

After replacing a head restraint, turn the right-hand mounting clockwise.

WARNING

DO NOT drive with the head restraints removed from occupied seats.

Backrest release lever (3-door models)



H5234

To enable rear seat passengers to enter or exit the vehicle, lift the backrest release lever upwards to fold the front seat backrest forwards.

After the backrest has been returned to its normal, upright position, ensure that it is securely retained by attempting to pull it forward again, but without operating the release lever. There should be no appreciable movement.

The rear seat access lever also acts as a seat belt presenter, improving access to the seat belt (see 'Seat belt presenter (3-door models)', page 42).

WARNING

Ensure that the backrest is secure before driving.

Seats

HEATED FRONT SEATS*

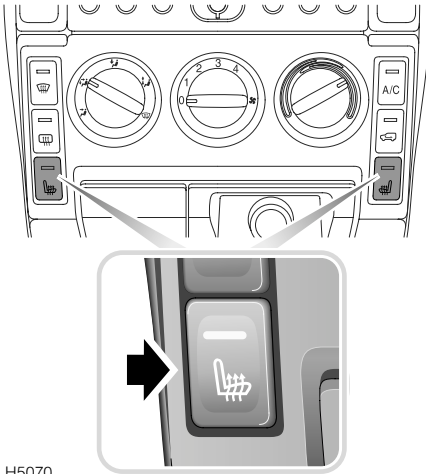

H5070

With the starter switch turned on and the engine running, press the switches to operate the heating elements in either the driver's or front passenger seat (the indicator light in the switch illuminates). Press a second time to switch off.

NOTE: The seat heaters will switch off automatically 45 seconds after the starter switch is turned off, or either front door is opened.

The seat heaters are thermostatically controlled and operate intermittently to achieve and then maintain a predetermined temperature between 26°C and 36°C.

NOTE: Owners should be aware that the seat heaters consume considerable power from the battery and for this reason, it is recommended that they are operated only with the engine running.

Seats

REAR SEATS

Folding the rear seats

On vehicles not fitted with 60/40 split rear seats the whole seat can be folded forwards to increase luggage space. On vehicles fitted with 60/40 split rear seats, either or both parts of the seat can be folded.

NOTE: Before folding the rear seats, ensure that the centre rear seat belt is unbuckled. Also ensure that the front seats are moved forward and the backrest is not reclined. This will avoid damaging the rear of the front seats when a rear seat is folded.

WARNING

Ensure that the rear seat backrests are securely latched in the upright position when the seat is in use and when loads are carried in the luggage area.

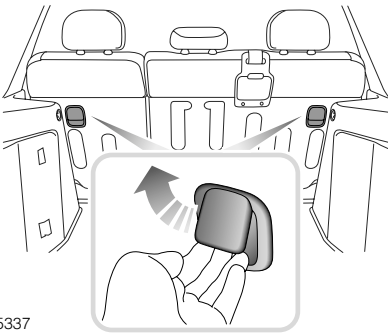

H5337

Lift the release levers (see inset) to release the backrest (lift both levers simultaneously on vehicles without 60/40 split seats) and fold the backrest forwards.

WARNING

DO NOT carry unsecured equipment, tools or luggage that could move, causing personal injury in the event of an accident, or emergency manoeuvre - where possible, use the seat belts to secure luggage carried on the seats.

Accommodating long loads

Remove the head restraints from the front passenger and rear seats (see 'Head restraint removal', page 36), move the front passenger seat forwards as far as possible and fully recline the seat backrest. Finally, fold the rear seat backrest (or the appropriate part of the backrest in the case of 60/40 split seats) fully forward as shown.

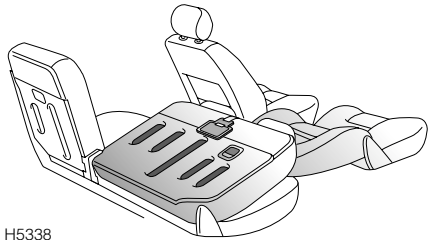

H5338

Loads that are too long to be carried inside the vehicle should be carried on the roof. (See 'ROOF RACK', page 147).

If it is necessary to carry a load that protrudes through the taildoor, or taildoor window, be aware of any territorial restriction restricting the length of any such load. In addition, ensure that loads DO NOT rest on the glass of a partially open window. Damage to the glass or window mechanism may occur.

Seats

WARNING

You are advised NOT to carry loads which require driving with the taildoor or taildoor window open - poisonous fumes will be drawn into the vehicle! If driving the vehicle in this condition is unavoidable, switch the heater to face level vents with all vents open, close the sunroof and windows and turn the air blower to position 4.

Maximum luggage space

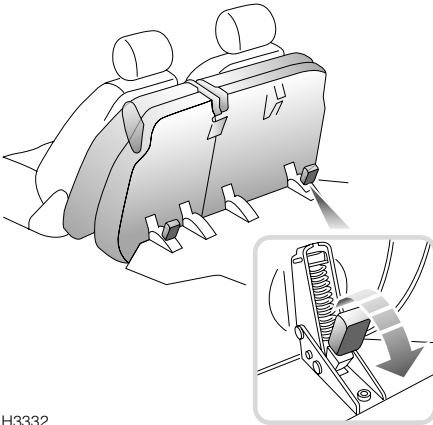

H3332

To create an extra large luggage area:

1. Lift the seat release levers to release the backrest and fold the seat backrest forward.
2. Tip the whole seat assembly forward as shown in illustration and readjust the front seats as required.

To return the seats to their normal position; push the seat base release levers (shown in lower inset) rearwards to unlock the seat base and unfold the seats. Ensure the seat backrests are properly secured by attempting to push them forwards - there should be no movement.

WARNING

It is extremely dangerous to ride in the cargo area. In a collision, anyone riding in this area is more likely to be injured or killed. Do not allow anyone to ride in any area of your vehicle that is not equipped with seats and safety belts. Be sure that everyone in your vehicle is in a seat and using a safety belt properly.

'Latch secure' indicator

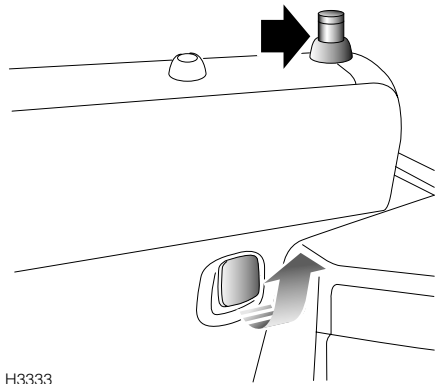

H3333

A 'latch secure' indicator, mounted on the top of the right hand side of the rear seat backrest, will pop up showing a red band, when the catch is released.

When returning the seat to the upright position, ensure the indicator drops back into the backrest and that the red band is no longer visible - this confirms that the larger portion of the backrest is secure.

NOTE: The 'latch secure' indicator does NOT indicate that the smaller portion of the 60/40 split backrest is secure - this must be checked individually.

NOTE: When returning the seats to the upright position, ensure that the seat belts are not trapped!

Seat Belts

SEAT BELT SAFETY

Seat belts fitted to your vehicle are designed for adults and larger children. Each belt should be used by one occupant only.

Observe the following precautions:

- DO make sure ALL passengers are securely strapped in at all times, using the appropriate restraint - even for the shortest journeys.
- ALWAYS adjust seat belts to eliminate any slack in the webbing. DO NOT slacken the webbing by holding the belt away from the body - to be fully effective, the seat belt must remain in full contact with the body at all times.
- ALWAYS fit the lap strap as low on the hips as possible (never across the abdomen), and ensure that the diagonal belt passes across the shoulder without slipping off or pressing on the neck.
- DO NOT wear seat belts over hard, sharp or fragile items in clothing, such as pens, keys, spectacles etc.
- Always replace a seat belt assembly that has withstood the strain of a severe vehicle impact, or if the webbing shows signs of fraying.
- Where possible use the seat belts to secure large items of luggage that are to be carried on the seats - in the event of an accident, unsecured items become flying missiles capable of causing serious injury.
- DO NOT use a seat belt that is twisted or obstructed in any way that could impede its smooth operation.

- DO NOT allow front seat occupants to travel with the seat backs reclined steeply rearwards. Optimum benefit is obtained from the seat belt with the seat back angle reclined to a maximum of 30 degrees from the upright (vertical) position.
- DO NOT allow foreign matter (particularly sugary food and drink) to enter the seat belt locks - such substances can render the locks inoperative.
- In most countries, all occupants are required by law to wear a seat belt, unless they have been issued with a medical exemption certificate.

WARNING

The airbag supplementary restraint system (see 'Airbag SRS') is designed to add to the overall effectiveness of the seat belts. It does not replace them. SEAT BELTS MUST ALWAYS BE WORN!

Ensure that all seat belts are worn correctly - an improperly worn seat belt increases the risk of death or serious injury in the event of a collision.

Seat Belts

PREGNANT WOMEN

WARNING

Pregnant women must wear a correctly positioned seat belt; it is safer for mother and unborn child.

There are many ways that the belt can be misused for the sake of comfort, but there is only one way of wearing it safely.

During pregnancy, women should wear the lap belt across the hips below the baby, with the diagonal belt passing across the shoulder, between the breasts and to one side of the baby - if in doubt, consult a doctor.

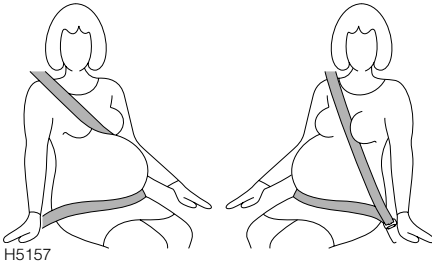

Never place anything between you and the seat belt in an attempt to cushion the impact in the event of an accident. It can be dangerous and reduce the effectiveness of the seat belt in preventing injury.

SEAT BELTS

To minimise injury in the event of an accident, it is important that seat belts are worn correctly. Read the instructions below and the advice contained under the heading 'SEAT BELT SAFETY', page 40.

Fastening the seat belts

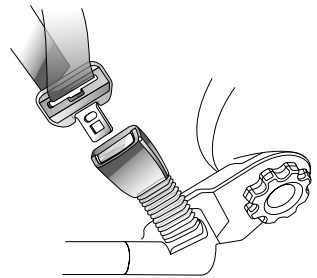

Inertia reel belts are fitted to all front and rear seating positions.

Pull the belt over the shoulder and across the chest and, ensuring that the webbing is not twisted, insert the metal tongue plate into the buckle nearest the wearer - a 'CLICK' indicates that the belt is securely locked.

NOTE: The centre rear seat belt* tongue plate will not latch into either of the outer seating position buckles.

Seat belts are designed to bear upon the bony structure of the body (pelvis, chest and shoulders) and can only be worn safely with the seats in a near upright position - DO NOT allow front seat occupants to travel with the seat steeply reclined.

NOTE: Where possible, rear seat passengers should adjust their position on the seat to enable the seat belt webbing to cross the shoulder without pressing on the neck.

Seat Belts

Releasing the belt

Press the RED button on the seat belt buckle.

Front seat belt upper anchorage adjustment (5-door models)

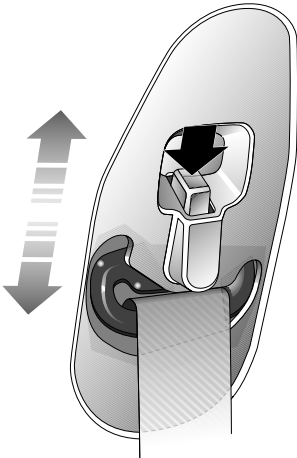

H2344A

The height of the seat belt upper anchorage can be adjusted for comfort AND safety. Adjust the height of the seat belt anchorage point by pressing the button (arrowed in illustration) and sliding the anchor up or down. For safety, the seat belt should always be worn with the webbing crossing the shoulder MIDWAY BETWEEN THE NECK AND THE EDGE OF THE SHOULDER.

Ensure the anchorage has 'clicked' into one of the locked positions before driving, and DO NOT adjust the height once the vehicle is in motion.

Seat belt presenter (3-door models)

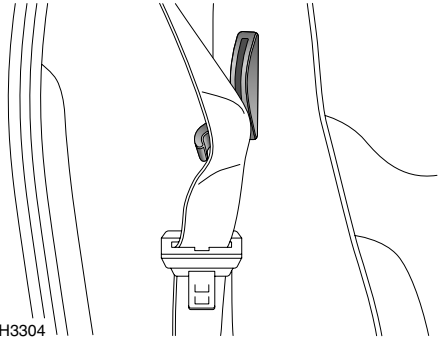

The rear seat access lever can be used as a seat belt presenter to improve accessibility of the front seat belts.

Seat Belts

SEAT BELT PRE-TENSIONERS

The seat belt pre-tensioners activate in conjunction with the airbag SRS and provide additional protection in the event of a severe frontal impact on the vehicle (see 'HOW THE AIRBAG SRS WORKS', page 48). The pre-tensioners automatically retract the seat belts fitted to the front seats. This reduces any slack in both the lap and diagonal portions of the belts, thereby reducing forward movement of the belt wearer in the event of a severe frontal collision.

The airbag SRS warning light on the instrument panel will alert you to any malfunction of the seat belt pre-tensioners.

If the pre-tensioners have been activated, the seat belts will still function as restraints, and must be worn in the event that the vehicle remains in a driveable condition.

NOTE: *The seat belt pre-tensioners will NOT be activated by rear, side or minor frontal impacts.*

WARNING

After the seat belt pre-tensioners have been activated once, they MUST BE REPLACED by a Land Rover Dealer/Authorised Repairer. Failure to replace the pre-tensioners will reduce the efficiency of the vehicle's front restraint systems.

After any frontal impact, always have the seat belts and pre-tensioners checked and, if necessary, replaced by a Land Rover Dealer/Authorised Repairer.

In the interests of safety, it is recommended that removal or replacement of the front seats and seat belts should be carried out only by a Land Rover Dealer/Authorised Repairer.

Second row seat belt locking mechanism

The second row seat belts have a special locking mechanism which aids the retention of child seats. The procedure to install a child seat is as follows:

1. Install the child seat in the vehicle, attach the seat belt and secure the buckle in accordance with the manufacturer's fitting instructions.
2. Pull on the shoulder section of the belt to unreel all of the remaining webbing to the limit of its travel. This will engage the automatic locking feature, which then acts as a ratchet, allowing the webbing to retract ONLY.
3. Allow the seat belt to retract onto the child seat (a 'clicking' sound will confirm that the ratchet has engaged), while firmly pushing the child seat into the vehicle seat.
4. Ensure there is no slack in the seat belt by pulling upwards on the shoulder belt immediately above the child restraint. The seat belt should now be locked and the child seat held firmly in position.

Once the child seat is removed and all the seat belt webbing is allowed to retract, the seat belt locking mechanism reverts to normal operation.

NOTE: *Where possible, use the seat belt automatic locking mechanism to secure large items of luggage that are to be carried on the seats - in the event of an accident, insecure items become flying missiles capable of causing serious injury.*

Seat Belts

Service information

WARNING

DO NOT attempt to service, repair, replace, modify or tamper with any part of the pre-tensioner and airbag SRS, or wiring in the vicinity of a pre-tensioner or airbag SRS component; this could cause the system to activate, resulting in personal injury.

After fifteen years from the original date of registration (or the installation date of a replacement pre-tensioner), some components will need to be replaced by a Land Rover Dealer/Authorised Repairer (note the 'Seat belt pre-tensioner replacement date' shown on page 2 of the Service Portfolio book).

In addition, ALWAYS contact your dealer if:

- an airbag inflates.
- a pre-tensioner activates.
- the front or side of the vehicle is damaged, even if the pre-tensioner has not activated.

CARING FOR SEAT BELTS

Regularly inspect the belt webbing for signs of fraying, cuts and wear; also pay particular attention to the condition of the fixing points and adjusters.

DO NOT bleach or dye the webbing and avoid contaminating the webbing with polish, oil or chemicals (see 'Seat belts', page 194).

Testing inertia reel belts

- With the seat belt fastened, give the webbing near the buckle a quick upward pull. The buckle must remain securely locked.
- With the seat belt unfastened, unreel the webbing to the limit of its travel. Check that unreeling is free from snatches and snags and then allow the belt to FULLY retract.
- Partially unreel the webbing, then hold the tongue plate and give it a quick forward pull. The mechanism must lock automatically and prevent any further unreeling.

If a seat belt should fail any of these tests, contact your dealer immediately.

WARNING

Always replace a seat belt that shows signs of webbing damage or has withstood the strain of a severe vehicle impact.

Child Restraints

CHILD SAFETY SEATS

Seat belts fitted to your vehicle are designed for adults and larger children. It is very important that all infants and children under 12 are restrained in a suitable child safety seat appropriate to their age and size (see table).

Only fit a child safety seat of a type approved for the specific seating positions in your vehicle (see table), and ensure the seat manufacturer's fitting instructions are followed exactly.

WARNING

Do not attempt to fit a child safety seat in the central rear position on 3-door vehicles fitted with only four seats.

For optimum safety, children should travel in the rear of the vehicle at all times; front passenger seat travel is NOT recommended. However, if a passenger airbag is fitted and it is ESSENTIAL that a child travels in the front, set the vehicle seat fully rearward and seat the child in an approved FORWARD-FACING child seat. DO NOT use a rear-facing child seat - an inflating airbag could impact with the seat and cause serious injury!



The above symbol affixed to the passenger side fascia panel of your vehicle, warns against the use of a REAR-FACING child safety seat in the front passenger seat, when a passenger airbag is fitted. This type of seat could cause serious injury to a child in the event of an airbag deployment.

WARNING

DO NOT install a rear-facing child safety seat in a passenger seat equipped with an airbag system. Failure to follow this advice could result in serious injury, or even death, for the child in the event of an airbag deployment.

Child Restraints

NOTE: Child restraint information given in the table is correct at time of going to press. Please refer to your dealer for the latest information.

| Mass Group (As displayed on Child Restraint packaging) | Seating Positions | | | |
|---|---------------------------------|------------------------------|------------------------------|-------------|
| | Front Passenger All vehicles | Rear Outboard 2 seater | Rear Outboard 3 seater | Rear Centre |
| 0 = Up to 10 kg (0-9 months) | X | U | L | L |
| 0+ = Up to 13 kg (0-18 months) | X | U | L | L |
| I = 9 to 18 kg (9 months - 4 years) | UF** | U | L | L |
| II & III = 15 to 36 kg (4-12 years) | UF** | U | L | L |
| <p>U = Suitable for 'universal' category restraints approved for this mass group. L = Suitable for particular child restraints as listed below. UF = Suitable for Forward Facing 'universal' category restraints approved for this mass group. X = Not suitable for child restraints in this mass group. Group 0 - BRITAX Rock-A-Tot. Group 0+ - BRITAX Rock-A-Tot. Group I - BRITAX Renaissance. Group II & III - BRITAX Horizon Booster.</p> <p>NOTE: Seating positions marked ** will accept 'universal' seats provided that the seat back is positioned vertically.</p> <p>WARNING! Do not install a rear facing child restraint in a passenger seat equipped with an airbag system.</p> | | | | |

Airbag SRS

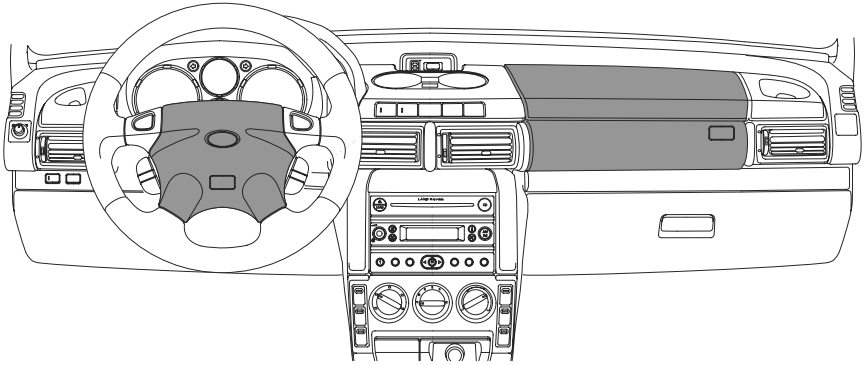

H5204

AIRBAG SRS



The airbag supplementary restraint system (SRS) provides additional protection for the driver and front seat passenger, in the event of a severe frontal impact on the vehicle.

WARNING

*The airbag is a supplementary restraint system that provides **ADDITIONAL** protection in a frontal impact only - it does **NOT** replace the need to wear a seat belt. For maximum safety protection in all crash situations, a seat belt must be worn.*

Provided the front seat occupants are correctly seated, with seat belts properly worn, the airbags will provide additional protection to the chest and facial areas in the event of the vehicle receiving a severe frontal impact.

NOTE: *Inflation and deflation of the airbags takes place very quickly and will not protect against the effects of secondary impacts that may occur.*

The airbag(s) are located in the centre pad of the steering wheel and in the fascia panel above the glovebox (see illustration).

WARNING

Do not allow a front seat passenger to obstruct the operation of the airbag by placing feet, knees or any other part of the person, or any other objects in contact with, or in close proximity to, an airbag module.

WARNING

DO NOT attach or position items to or on an airbag cover (steering wheel centre pad or fascia panel), which could interfere with the inflation of the airbag or, if the airbag inflates, be propelled inside the car causing injury to the occupants.

Airbag SRS

To ensure correct deployment of the airbags, it is essential that obstructions are not allowed to intervene between an airbag and the occupant. The following are examples of the type of obstructions that could either, impede correct operation of the airbags, or jeopardise personal safety in the event of an airbag deployment:

- Accessories attached to or obscuring an airbag cover.
- Items of hand luggage, or other objects placed on an airbag cover.
- Feet, knees or any other part of the anatomy in contact with, or in close proximity to, an airbag cover.

Seating positions

In order to provide optimum protection in the event of a severe frontal impact, it is necessary for the airbags to deploy with considerable speed.

An inflating airbag can cause facial abrasions and other injuries if the occupant is too close to the airbag at the time of its deployment.

WARNING

To reduce the risk of accidental injury from inflating airbags, seat belts should be correctly worn at all times. In addition, both driver and front seat passenger should adjust their seat to provide the maximum practical distance from the airbags.

HOW THE AIRBAG SRS WORKS

In the event of a severe frontal impact, the airbag control unit monitors the rate of deceleration induced by the collision, to determine whether the airbags should be deployed.

Operation of the airbag SRS is dependent entirely on the rate at which the vehicle's passenger compartment changes speed as a result of a collision. The circumstances affecting different collisions (vehicle speed, angle of impact, type and size of object hit, for example), vary considerably and will affect the rate of deceleration accordingly.

NOTE: *The airbag SRS is not designed to operate as a result of rear collisions, minor frontal or side impacts or roll-over accidents; nor will it operate as a result of heavy braking or driving over bumps and potholes.*

It follows, therefore, that significant superficial damage can occur without the airbags deploying or, conversely, that a relatively small amount of structural damage may cause the airbags to be deployed.

NOTE: *Airbags will only deploy when they are required to supplement the restraining force of the seat belts.*

In the case of a severe frontal collision, both front airbags and seat belt pre-tensioners will be deployed.

Airbag SRS

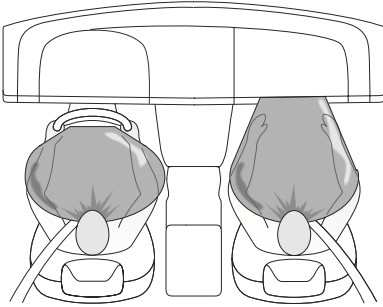

H5206

Airbag inflation is virtually instantaneous and occurs with considerable force, accompanied by a loud noise. The inflated bag, together with the seat belt restraint system, limit the movement of a front seat occupant, thereby reducing the risk of injury to the head and upper torso.

WARNING

An inflating airbag can cause facial abrasions and other injuries. Minimise the risk of injury by ensuring that front seat occupants are wearing their seat belts and are seated correctly, with the seat as far back as is practical.

When an airbag inflates, a fine powder is released. This is not an indication of a malfunction. However, the powder may cause irritation to the skin and should be thoroughly flushed from the eyes and any cuts or abrasions of the skin. After inflation the airbags deflate immediately. This provides a gradual cushioning effect for the occupant and also ensures that the driver's forward vision is not impaired.

WARNING

After inflation, some airbag components are hot - DO NOT touch until they have cooled.

Airbag SRS warning light

SRS

A warning light mounted on the instrument panel will alert you to any malfunction of the airbag SRS.

The light illuminates as a bulb and system check when the starter switch is turned to position 'I' and will extinguish after approximately five seconds. The airbag SRS should always be checked by a dealer if any of the following symptoms occurs:

- The warning light fails to illuminate when the starter switch is turned to position 'II'.
- The warning light fails to extinguish within approximately five seconds after the starter switch is turned to position 'II'.
- The warning light illuminates after the engine is started, or while the vehicle is being driven.

Airbag SRS

SERVICE INFORMATION

WARNING

DO NOT attempt to service, repair, replace, modify or tamper with any part of the airbag SRS, or wiring in the vicinity of an airbag SRS component; this could cause the system to activate, resulting in personal injury.

After fifteen years from the original date of registration (or the installation date of a replacement airbag SRS), the airbag modules will need to be replaced by a Land Rover Dealer/Authorised Repairer (see the 'airbag module replacement date' shown on page 2 of the Service Portfolio book). The dealer should stamp and sign the appropriate page once the work has been completed.

In addition, ALWAYS contact your Dealer/Authorised Repairer if:

- an airbag inflates.
- the front of the vehicle is damaged, even if the airbag has not inflated.
- any part of an airbag module cover (the steering wheel centre pad or fascia panel) shows signs of cracking or damage.

IMPORTANT

The components that make up the airbag SRS are sensitive to electrical or physical interference, either of which could easily damage the system and cause inadvertent operation or a malfunction of the airbag.

For your safety it is recommended that you seek the assistance of a Land Rover Dealer/Authorised Repairer to carry out any of the following:

- Removal or repair of any wiring or component in the vicinity of any of the SRS components, including the steering wheel, steering column, instrument and fascia panels.
- Installation of electronic equipment such as a mobile phone, two-way radio or in-car entertainment system.
- Modification to the front of the vehicle, including the bumper and chassis.
- Attachment of accessories to the front of the vehicle.

Disposing of vehicles

If you sell your vehicle, be sure to inform the new owner that the vehicle has an airbag SRS. In addition, make sure the new owner is aware of the airbag module replacement date shown on page 2 of the Service Portfolio book.

If your vehicle is to be scrapped; uninflated airbags are potentially very dangerous and must be safely deployed in a controlled environment by qualified personnel, before a vehicle is scrapped.

Steering Column

STEERING COLUMN ADJUSTMENT

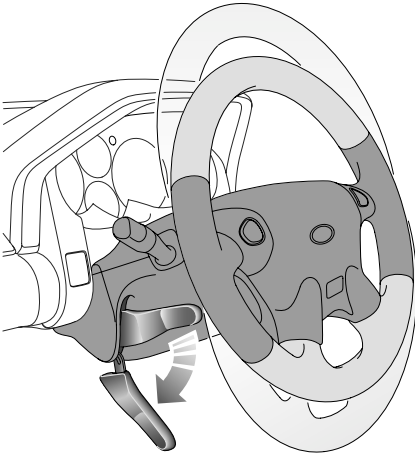

H5084

The angle of the steering column can be adjusted to suit your driving position:

1. With the vehicle stationary, push the locking lever fully down to free the steering column.
2. Move the steering wheel (up or down) into the desired position, making sure that the instrument panel is clearly visible.
3. When adjustment is complete, pull the locking lever fully up to lock the steering column in position.

WARNING

DO NOT adjust the steering column while the vehicle is in motion. This is extremely dangerous!

DO NOT drive the vehicle unless the locking lever is in the locked position (fully up).

Instruments

INSTRUMENT PANEL

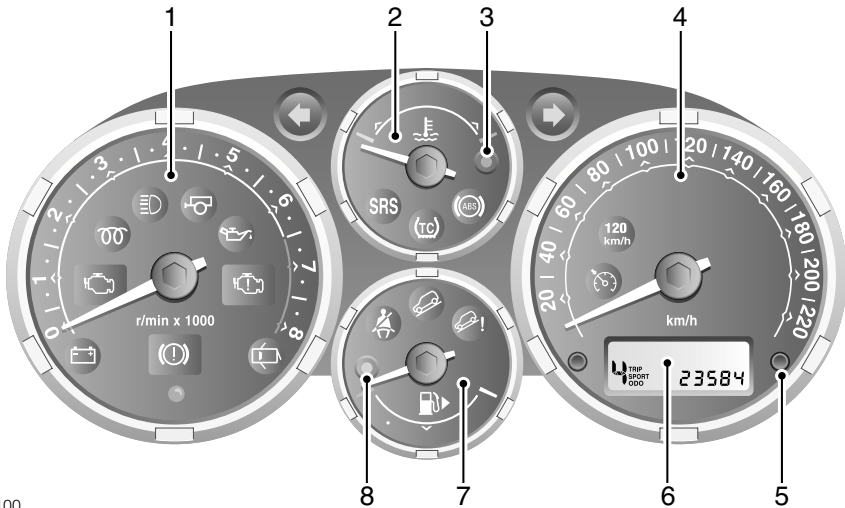

H5100

Petrol model illustrated

1. Tachometer

Indicates engine speed in revolutions per minute (x 1000). To protect the engine from damage, NEVER allow the tachometer pointer to enter the RED sector.

NOTE: On diesel models, the tachometer is only calibrated up to 6,000 rev/min.

2. Temperature gauge

This gauge indicates the temperature of the engine coolant. As the engine warms up, the pointer will rise to the mid-point of the gauge, where it should remain while the engine is operating at its normal temperature.

If the pointer reaches the RED sector, the coolant is too hot and severe engine damage could result; stop the vehicle as soon as safety permits and seek qualified assistance.

3. Over-temperature warning light

Illuminates when the engine coolant temperature reaches the RED sector (120°C). Illuminates as a bulb check when the starter switch is turned to position 'I' and extinguishes when the engine is started.

4. Speedometer

Indicates road speed in kilometres per hour.

5. Trip recorder reset button

When the starter switch is turned on, the display shows either the odometer reading or the trip recorder reading. By pressing the trip recorder reset button briefly, the display will change between the trip recorder and odometer modes. With the trip recorder mode displayed, press and hold the reset button for 2 seconds to reset the display to zero.

Pressing the button with the ignition off, will display the odometer reading for 5 seconds.

Instruments

6. Digital display

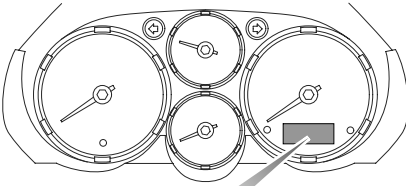

H5103

The panel displays the following:

1. Odometer reading (shows the total distance travelled by the vehicle). The word 'ODO' is displayed.
Trip recorder (for recording individual journey distances). The word 'TRIP' is displayed instead of 'ODO'.
2. Automatic gear selector position ('1', '2', '4', 'P', 'R', 'N', 'D') - automatic transmission only.
The word 'SPORT' confirms the selection of Sport mode - automatic transmission only.
Manual mode gear selection information ('1', '2', '3', '4' or '5') - automatic transmission only

For further information concerning the automatic transmission, (see 'CommandShift® TRANSMISSION', page 108).

7. Temperature display units

Press to change the temperature units shown on the digital display from Fahrenheit to Celsius, and vice versa.

8. Fuel gauge

The pointer indicates the fuel level when the starter switch is turned to position 'II'. After refuelling, the pointer rises to the new level after the starter switch is turned on. When the starter switch is turned off, the pointer quickly lowers to the 'empty' position.

An arrow on the face of the fuel gauge indicates the side of the vehicle on which the fuel filler is situated.

WARNING

Never allow the vehicle to run out of fuel - the resultant misfire could damage the catalytic converter.

NOTE: Driving on twisting or hilly roads may disturb the accuracy of the fuel gauge. It is advisable to check the fuel level when the vehicle is travelling on a straight, level road.

9. Low-fuel warning light

Illuminates when the fuel level is low (approximately 2 gallons (9 litres) remaining). If the light illuminates, refuel at the earliest opportunity.

Illuminates as a bulb check when the starter switch is turned to position 'II' and extinguishes when the engine is started.

Instruments

Instrument illumination control

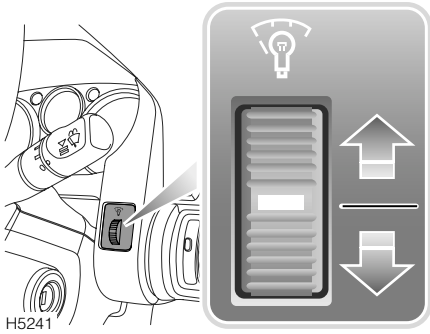

Rotate the control up to increase, or down to decrease the intensity of the instrument panel illumination.

The instrument illumination control also adjusts the level of illumination for all switch lighting sources forward of the driver.

Warning Lights

INSTRUMENT PANEL

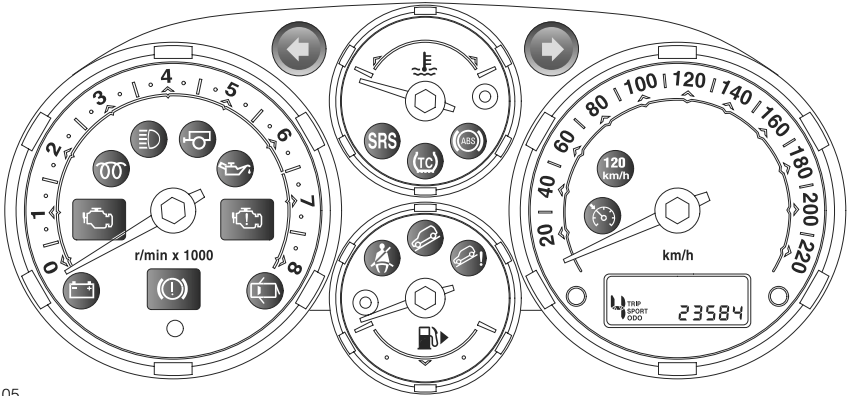

H5105

The location and specification of the warning lights may vary according to model and market requirements.

Direction indicators - GREEN



The left or right warning light flashes in time with the relevant direction indicator when they are operated. If either warning light fails to flash or flashes rapidly, the selected direction indicator light is not operating.

NOTE: If the hazard warning lights are operated, both direction indicator warning lights will flash together.

Headlight main beam - BLUE



Illuminates when the headlights are switched to main beam.

Cruise control - AMBER*



Illuminates when the cruise control master switch is turned on and cruise control is active, and extinguishes when the switch is turned off or if cruise control is deactivated.

Engine malfunction indicator - M.I.L - AMBER



Illuminates as a bulb check when the starter switch is turned to position 'II' and extinguishes when the engine is started. If the light illuminates while the engine is running, this indicates the detection of an emissions fault by the engine management system.

If the light illuminates and the vehicle drives normally:

- Arrange a service appointment at your earliest convenience - you may still drive the vehicle.

If the light flashes and/or the vehicle does not drive normally:

- Avoid high speeds and seek qualified assistance urgently.

Warning Lights

Handbrake & brake system - RED



The light illuminates when the handbrake is applied and extinguishes when it is fully released. If the light illuminates while the handbrake is released, a fault with the braking system is indicated, check the brake fluid level (see '*BRAKE FLUID*', page 178). If the light continues to illuminate, seek qualified assistance urgently.

Door open - RED



Illuminates when any of the doors (including the taildoor and bonnet) are not fully closed. DO NOT drive the vehicle with the light illuminated.

Traction control - AMBER



Illuminates as a bulb and system check when the starter switch is turned to position 'II' and extinguishes after approximately 4 seconds. The light illuminates for a minimum of 2 seconds, whenever traction control is operating.

If the light illuminates continuously while traction control is NOT operating, a fault with the system is indicated; seek qualified assistance.

The light also has an overheat function: if traction control is required, but the brakes are too hot, the light will flash for the period when traction control is required and traction has been lost.

ABS - AMBER



Illuminates for approximately 1 second as a bulb and system check when the starter switch is turned to position 'II', and then extinguishes. The light may blink during this time.

If the light remains on or subsequently illuminates while driving, a fault has been detected by the self-monitoring system. This means that full ABS control may not be available and you should seek qualified assistance urgently.

Hill descent control (HDC) 'failure' - AMBER



The light illuminates briefly as a bulb check when the starter switch is turned to position 'II'. The light will flash if the brakes become in danger of overheating and continue flashing until the brakes have cooled sufficiently to enable HDC to operate again (see also '*HDC fade-out*', page 114).

If the light illuminates at any other time, a fault in the system is indicated. If this occurs, deselect HDC and consult your Land Rover Dealer/Authorised Repairer.

Hill descent control (HDC) 'information' - GREEN



Illuminates briefly as a bulb check when the starter switch is turned to position 'II' and will illuminate when HDC is selected.

If HDC is selected when either of the operating gears is engaged (1st or reverse), the light will illuminate continuously.

When HDC is selected and a non-operating gear is engaged, the light will flash to inform the driver that HDC is selected, but not operating (see also '*HDC fade-out*', page 114).

Warning Lights

Low oil pressure - RED



Illuminates as a bulb check when the starter switch is turned to position 'II' and extinguishes when the engine is started. If the light remains on, flashes on and off or illuminates continuously when driving, serious engine damage could occur; stop the vehicle as soon as safety permits and SWITCH OFF THE ENGINE IMMEDIATELY. Seek qualified assistance before driving.

Seat belt - RED*



The light illuminates when the starter switch is turned to position 'II' as a reminder to the driver to ensure that the seat belts of all occupied seats are securely fastened. The light extinguishes after approximately five seconds, or when the driver's seat belt is fastened.

Airbag SRS - RED



The light illuminates when the starter switch is turned to position 'II' and extinguishes after about five seconds. If the light illuminates at any other time, seek qualified assistance urgently.

Overspeed - AMBER*



Illuminates as a bulb check when the starter switch is turned to position 'II' and extinguishes after approximately 2 seconds. The light will also illuminate when the vehicle's road speed exceeds 120 km/h and extinguishes again once road speed drops below 120 km/h.

Engine malfunction - AMBER



Illuminates briefly when the starter switch is turned to position 'II'. If it remains on, or illuminates at any other time, the engine management system requires attention. Stop the vehicle as soon as safety permits and switch off the engine for at

least 30 seconds; if the light illuminates again after the engine is restarted, it is permissible to continue driving (with reduced engine power), but qualified assistance must be sought as soon as possible, to prevent potential engine damage.

Battery charging - RED



The light illuminates as a bulb check when the starter switch is turned to position 'II' and extinguishes as soon as the engine is running. If it remains on, or illuminates when driving, a fault with the battery charging system is indicated. Seek qualified assistance urgently.

Glow plugs - AMBER (Diesel models)



Illuminates when the starter switch is turned to position 'II'. When the engine is cold, wait for the light to extinguish before starting. If the engine is warm, the light may not illuminate.

Trailer direction indicators - GREEN



Illuminates in conjunction with the vehicle direction indicator lights to show that all trailer indicator lights are functioning correctly. In the event of a bulb failure on the trailer, the warning light flashes once and then remains off.

When a trailer is not fitted, the warning light will flash once each time the direction indicator switch is operated.

NOTE: The trailer direction indicator light will also flash when the hazard warning lights are activated, whether a trailer is attached or not.

Lights & Indicators

DIRECTION INDICATORS

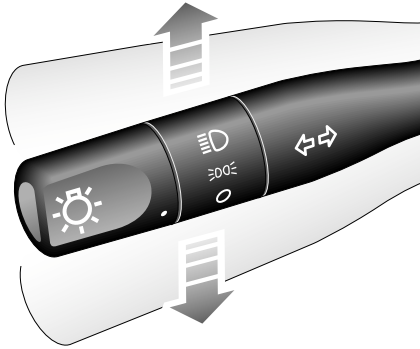

H5093

Move the lever DOWN to indicate a LEFT turn, and UP to indicate a RIGHT turn (the appropriate GREEN warning light on the instrument panel will flash in time with the direction indicators).

Hold the lever part-way up or down against spring pressure to indicate a lane change.

LIGHTS

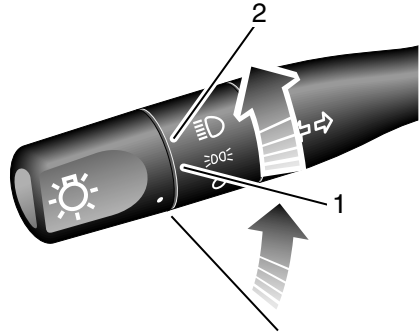

H5094

The side, tail and headlights operate with the starter switch in any position.

If the exterior lights are left on after the starter switch is turned off, a warning chime will sound as soon as the driver's door is opened. The chime will cease as soon as the lights are switched off, or the door is closed.

Side, tail and instrument panel lights

Turn lighting switch to position 1.

Headlights

Turn lighting switch to position 2.

Lights & Indicators

Headlight main and dipped beams

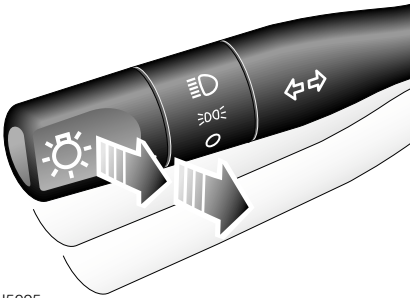

H5095

Pull the lever fully towards the steering wheel to change headlight beams (BLUE warning light glows when the headlights are on main beam).

To flash the headlights, pull the lever part way towards the steering wheel and release.

Headlight levelling

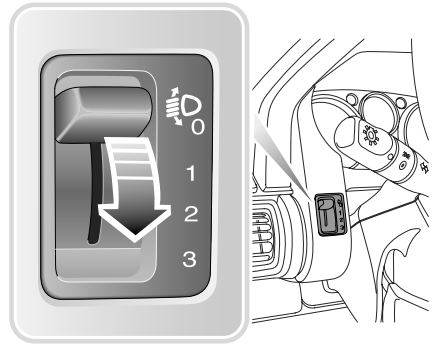

H5072

The angle of the headlight beams is affected by the distribution of weight inside the vehicle. The headlights should be adjusted so that the point at which the beams meet the road surface ahead of the vehicle provides adequate illumination without dazzling other road users.

The four-position switch should be used to adjust the headlight beams in relation to the vehicle loadings identified below.

| Loading Condition | Switch Position | | |
|----------------------------------|--|-----------------------------------|------------------------------|
| | 4 Cyl. Petrol & Diesel Standard Suspension | 6 Cyl. Petrol Standard Suspension | All Models Sports Suspension |
| Driver only. | 0 | 0 | 0 |
| Driver plus one front passenger. | 0 | 0 | 0 |
| All seats occupied. | 1 | 1 | 1 |
| All seats occupied plus MRAL. | 2 | 3 | 1 |
| Driver plus MRAL. | 3 | 3 | 2 |

NOTE: MRAL = Maximum Rear Axle Load.

Lights & Indicators

FOG LIGHTS

WARNING

Fog lights should ONLY be used when visibility is severely restricted - other road users could be dazzled in clear conditions.

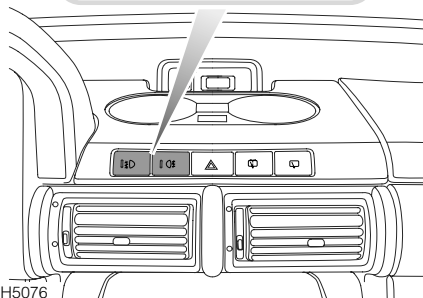
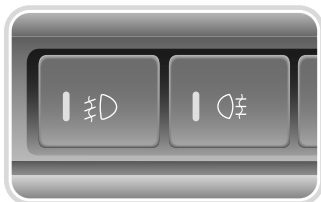

H5076

Front fog lights*

 Press to operate, press a second time to switch off (the green indicator light in the switch illuminates when the fog lights are switched on).

The front fog lights operate ONLY when the starter switch is at position 'II' and the side or headlights are also switched on. The front fog lights extinguish automatically when the side lights or the starter switch is turned off, but will automatically be reselected when the starter switch is turned back on.

DO remember to switch off as soon as visibility is clear.

Rear fog guard lights



Press to operate, press a second time to switch off (the red indicator light in the switch illuminates when the fog guard lights are switched on).

The rear fog guard lights operate ONLY when the starter switch is turned to position 'II' and the headlights are switched on. Switching off the headlights, or turning the starter switch to position '0', will automatically extinguish the rear fog guard lights.

DO remember to switch off as soon as visibility is clear.

HAZARD WARNING LIGHTS

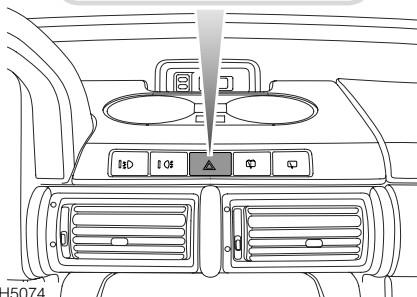
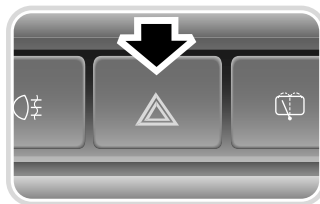

H5074



Press to operate; all the direction indicator lights (including those fitted to a trailer) will flash together. Use ONLY in an emergency to warn other road users when your stationary vehicle is causing an obstruction, or is in a hazardous situation. Remember to switch off before moving away.

Wipers & Washers

OPERATING

The wipers and washers will only operate when the starter switch is turned to position '1' or 'II'.

IMPORTANT

- DO NOT operate the wipers on a dry screen.
- In freezing or very hot conditions, ensure that the blades are not frozen or stuck to the glass.
- In winter, remove any snow or ice from around the arms and blades, including the wiped area of the windscreen and the heater air intakes.

NOTE: If the wiper blades have stuck to the glass, a thermal cut-out may temporarily prevent the wiper motor from operating. If this is the case, switch the wipers off, free them from the obstruction and then switch on again.

WINDSCREEN WIPERS

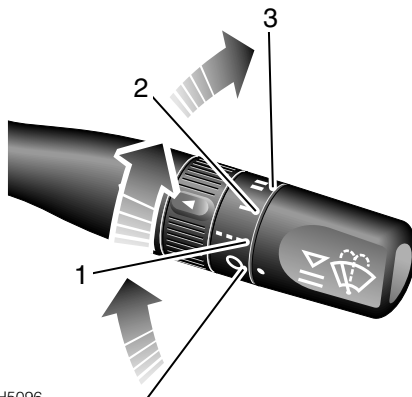

H5096

Intermittent wipe

Turn switch to position 1.

Normal speed wipe

Turn switch to position 2.

Fast speed wipe

Turn switch to position 3.

NOTE: If the front screen wipers are operating (in either intermittent or continuous mode), the rear wiper operates automatically whenever reverse gear is selected.

Wipers & Washers

Single wipe

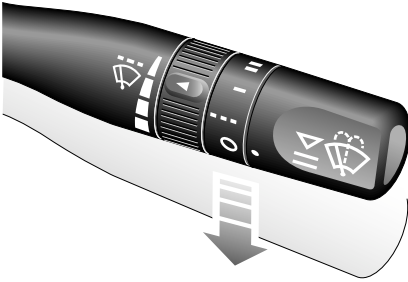

H5097

Pull the lever down and release immediately.

NOTE: With the lever held down, the wipers will operate at high speed until the lever is released.

Variable delay (intermittent wipe)

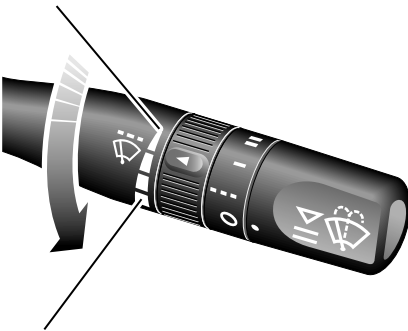

H5098

Rotate the inner switch to vary the delay between wipes.

WINDSCREEN WASHERS

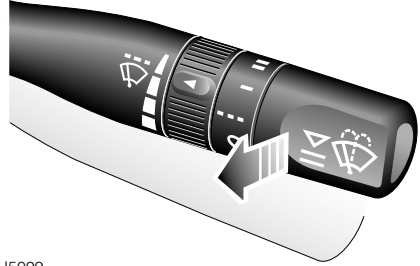

H5099

Pull the lever toward the steering wheel. The windscreen wipers will operate in conjunction with the washers for as long as the lever is held in this position, the wipers continuing for a further 3 to 4 wipes after the lever is released.

Wipers & Washers

REAR SCREEN WIPER AND WASHER

Rear window wash/wipe

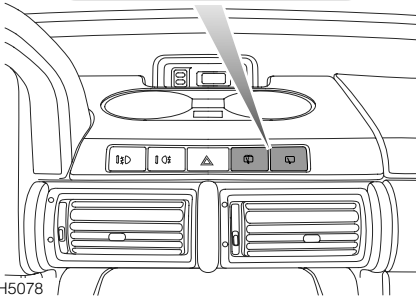

Rear screen wiper



Press to operate: after continuously wiping 3 or 4 times, the wiper operates intermittently (approx. once every 6 seconds) until switched off.

NOTE: When reverse gear is selected, the rear wiper will operate continuously in tandem with the front wipers.

NOTE: Opening the taildoor, or lowering the rear screen, will switch the rear wiper off.



Press and hold the switch for the required duration of screen washing. The wiper operates automatically during washing and continues for a further 4 wipes (approx.) after the switch is released.

Horn

HORN

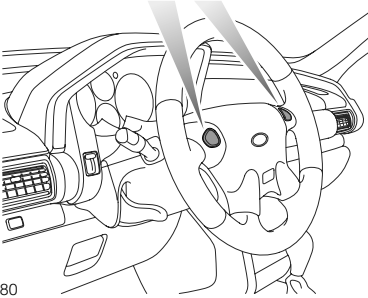
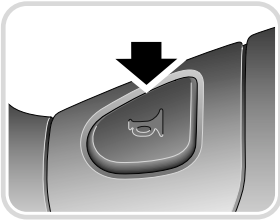

H5080

To operate, press either of the horn switches set into the steering wheel pad.

Mirrors

EXTERIOR MIRRORS

NOTE: The mirror glass is convex, providing a wider field of vision. As a result, objects reflected in the mirror are closer than they appear.

Adjustment

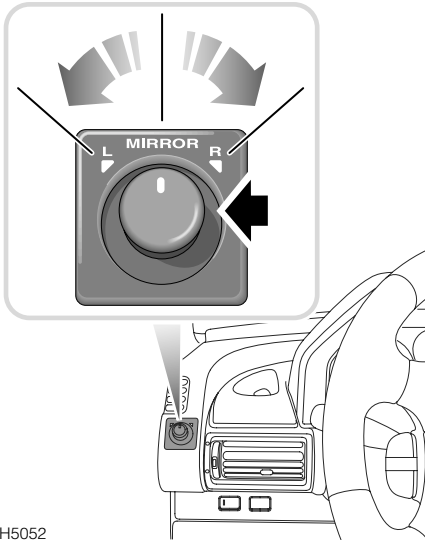

H5052

- Turn the control to the 'L' or 'R' position to select either the left or right hand mirror.
- With the starter switch turned to position 'II', push the control in the appropriate direction to tilt the mirror glass up/down/left or right.
- When adjustment is complete, return the control to the OFF position (midway between 'L' and 'R').

Heating elements

The exterior mirrors have integral heating elements for dispersing ice and mist, which operate automatically whenever the starter switch is in position 'II'.

Folding the mirror body

The body of each door mirror is designed to fold forwards or rearwards on impact. They can also be folded back manually towards the side windows into a 'park' position, to enable the vehicle to negotiate narrow openings.

Manual operation: On some vehicles this operation can be carried out manually, by physically pushing the mirror bodies back towards the side windows, and then pulling them back into the normal (extended) positions.

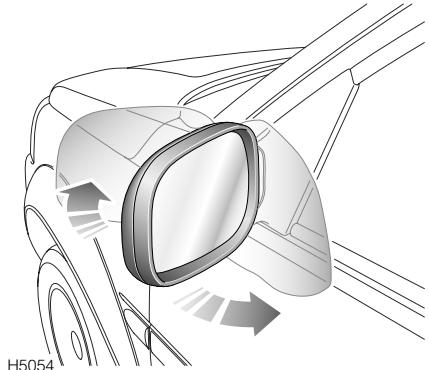

H5054

Mirrors

Electric operation:*

On some vehicles, mirror folding can be carried out electrically, as follows:

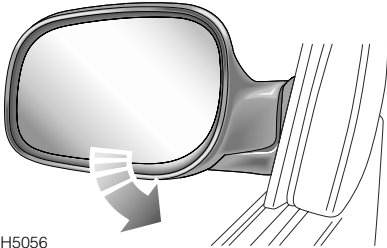
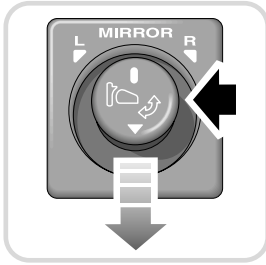

H5056

1. Ensure the mirror control is turned to the centre position.
2. Push the control down once to fold the mirrors back towards the side windows.
3. Before driving, push the control down a second time to return the mirrors to their normal driving position.

If one mirror is accidentally knocked out of position, an additional operation of the switch will re-synchronise them.

NOTE: After several consecutive operations of the control, the mirror motor will cut-out. This is not a fault and occurs automatically to prevent the motor from overheating.

INTERIOR MIRROR

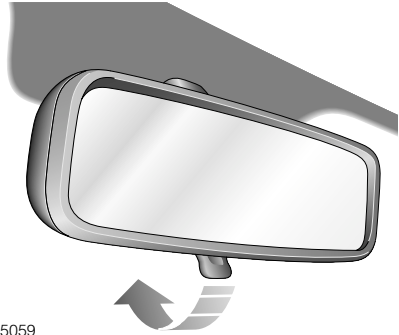

H5059

The interior mirror can be dipped to reduce glare from following vehicles. In the event of excessive glare, move the lever at the base of the mirror forward to 'dip' the mirror. Normal visibility is restored by pulling the lever back to its original position.

NOTE: In some circumstances, the view reflected in a 'dipped' mirror can confuse the driver as to the precise position of following vehicles. Remember to take additional care!

Mirrors

VANITY MIRROR*

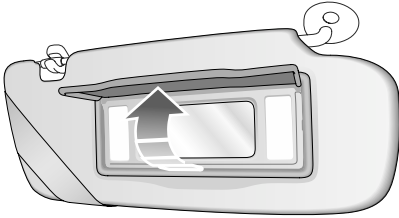

H5061

To use the vanity mirror, pull down the passenger's sun visor. On some models, the vanity mirror is illuminated; lift the mirror cover to illuminate.

NOTE: Always close the cover, or on vanity mirrors not fitted with a cover, always return the visor to its stowed position when not in use, to avoid possible scorching of the seats by the sun reflected in the mirror.

Windows

ELECTRIC WINDOW CONTROLS

WARNING

Accidental closing of an electrically operated window on fingers, hands or any vulnerable part of the body, can result in serious injury. Always observe the following precautions:

ISOLATE the rear window switches when carrying children.

ENSURE that children are kept clear whilst raising or lowering windows.

ENSURE that all adult passengers are familiar with the controls and the potential dangers of electrically operated windows.

DO NOT allow passengers to extend any part of their bodies through a window aperture while the vehicle is moving - injury from flying debris, branches of trees or other obstructions could occur.

It is recommended that the starter key be removed when leaving the vehicle.

5 DOOR VEHICLES

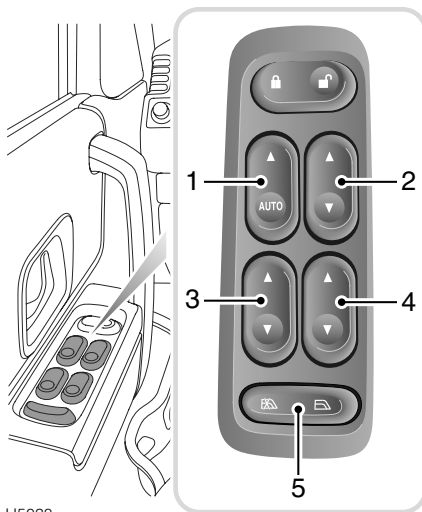

H5038

The switches on the driver's door console operate the windows as follows:

1. Left hand front window.
2. Right hand front window.
3. Left hand rear window.
4. Right hand rear window
5. Isolation switch for rear door window switches.

NOTE: *Electric rear windows can also be operated by the individual switches mounted on each rear door, provided that the isolation switch has not been activated.*

Windows

Operating the windows

The electric windows can be operated when the starter switch is at position 'II' and for up to 45 seconds after the starter switch is turned off (provided neither front door is opened in the meantime).

Press and hold the bottom half of a switch to lower and the upper half to raise. The window will stop moving when the switch is released.

NOTE: ENSURE that all adult passengers are familiar with the controls and the potential dangers of electrically operated windows.

Rear window isolation switch

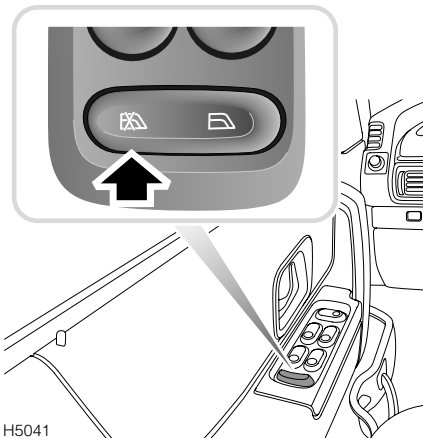

Press switch '5' as indicated to isolate the rear window switches. Press the other end of the switch to restore independent control.

'One touch' down (Driver's door only)

By pressing (and then releasing) the bottom half of switch '1' (AUTO) to the second detent position, the window will open fully at a single touch. Window movement can be stopped at any time by briefly pressing the upper half of the switch.

Front door - passenger's window switch

The front seat passenger can also independently control the raising and lowering of their window by using the switch on the passenger door. Press and hold the bottom half of the switch to lower and the upper half to raise. The window will stop moving when the switch is released.

Rear door - passenger's window switch

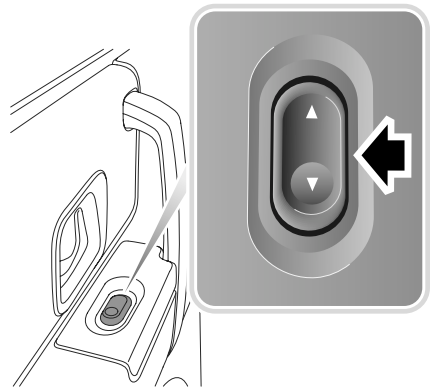

H5040

Rear seat passengers can control the raising and lowering of their window by using the switch on either of the rear doors. (Provided that the rear windows have not been isolated by the driver).

Press and hold the bottom half of a switch to lower and the upper half to raise. The window will stop moving when the switch is released.

NOTE: ENSURE that all adult passengers are familiar with the controls and the potential dangers of electrically operated windows.

Windows

3 DOOR VEHICLES

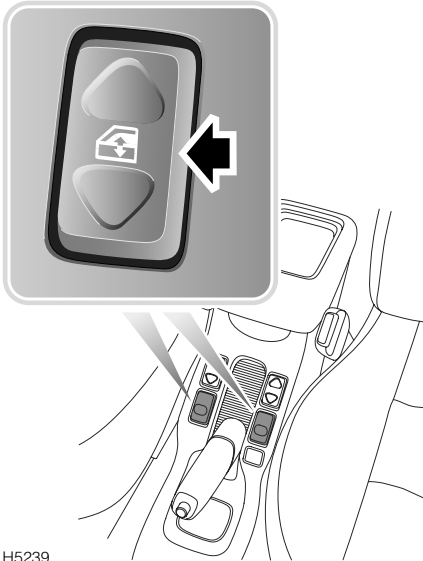

H5239

The switches on centre console operate the windows as follows:

Operating the windows

The electric windows can be operated when the starter switch is at position 'II' and for up to 45 seconds after the starter switch is turned off (provided neither door is opened in the meantime).

Press and hold the bottom half of a switch to lower and the upper half to raise. The window will stop moving when the switch is released.

NOTE: ENSURE that all adult passengers are familiar with the controls and the potential dangers of electrically operated windows.

'One touch' down (Driver's door only)

By briefly pressing (and then releasing) the bottom half of the driver's window switch, the window will open fully at a single touch. Window movement can be stopped at any time by briefly pressing the upper half of the switch.

Windows

ELECTRIC TAILDOOR GLASS

WARNING

Long loads should be carried on the roof rack. If it is necessary to carry a load that protrudes through the taildoor window, the weight of the load must NOT rest on the glass of a partially open window. Damage to the glass or window mechanism may occur (see also 'Accommodating long loads', page 38).

NOTE: The taildoor glass can be lowered from outside the vehicle, to enable easy access to the loadspace area when it is impossible or inconvenient to open the taildoor.

Raising and lowering

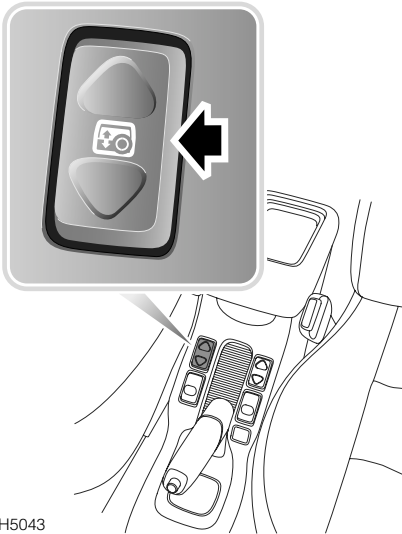

From inside the vehicle:

With the starter switch in position 'II', press and hold the bottom half of the switch to lower the glass, movement will stop when the switch is released.

Press the upper half of the switch to raise the glass. If the switch is released before the glass is fully raised, it will automatically lower again.

NOTE: On 3-door models, the taildoor glass cannot be raised if the soft-back is raised/removed or if the hard-back is removed.

One touch down:

By briefly pressing (and then releasing) the bottom half of the switch, the taildoor glass will open fully at a single touch.

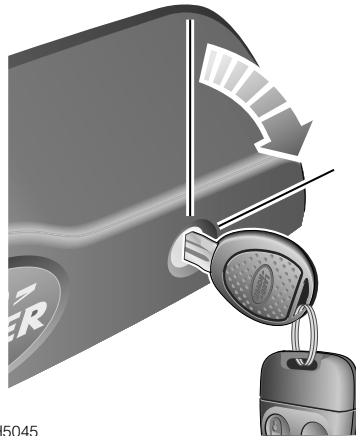

From outside the vehicle:

Press and hold the UNLOCK button on the remote handset (hold for 2 seconds) - the taildoor glass will fully lower.

To raise the glass, insert the starter key into the switch mounted in the taildoor handle and turn clockwise. If the switch is released before the glass is fully raised, it will automatically lower again.

NOTE: If the vehicle is locked when the glass is lowered using the handset, the driver's door will unlock and the security features will be disarmed.

Remember to relock the vehicle (if required).

Windows

Battery disconnection

If the battery has been disconnected, the taildoor glass will need to be recalibrated. If the alarm was armed when the battery was disconnected (or discharged), disarm the alarm after reconnection - the glass will fully lower. This will happen automatically if the alarm was in a disarmed state when the battery was disconnected.

After battery reconnection, fully raise the glass - the taildoor glass is now recalibrated (if the glass is not fully raised, an error 'beep' will sound).

REAR VENTILATOR WINDOWS (3-door models)

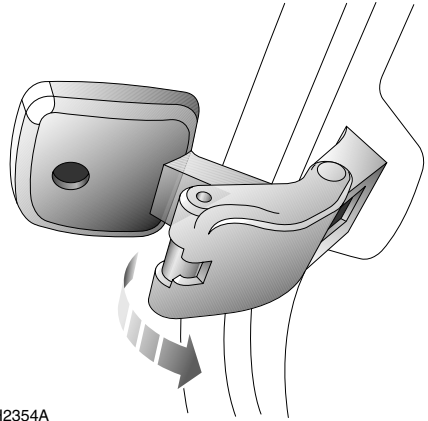

H2354A

To open, pull the catch forwards and push outwards until the window 'clicks' into position.

To close, pull the centre of the catch inwards, then push rearwards until the catch is felt to 'clip' into the locked position.

NOTE: *Ensure that children are kept clear while operating the windows.*

Sunroof

ELECTRIC SUNROOF*

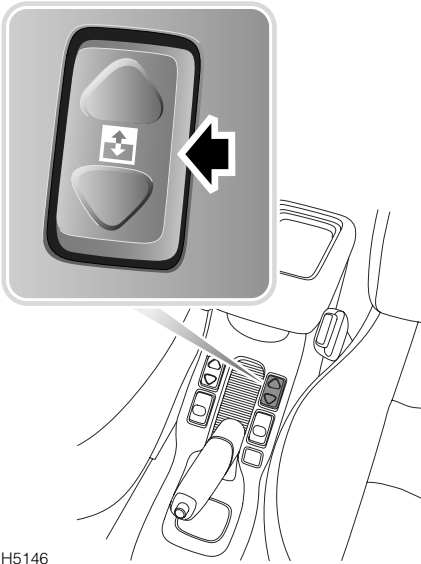

H5146

The sunroof can be operated when the starter switch is turned to position 'II' and for up to 45 seconds after the starter switch is turned off (provided neither front door is opened in the meantime).

The roof opens in two separate phases as follows:

- **To tilt the roof:** Press the bottom half of the switch - the rear edge of the roof rises to the tilted position.
- **To open the roof:** With the sunroof fully tilted, press the bottom half of the switch - the roof remains tilted and slides towards the rear until fully open or the switch is released.

NOTE: Do not operate the sunroof when it is obstructed, or covered in ice or snow - damage could be caused.

To close the roof: press the upper half of the switch - the sunroof will first close to the tilted position, then it will return the tilted roof to the closed position. The sunroof can be stopped (at any position) by releasing the switch.

WARNING

Accidental closure of a sunroof on fingers, hands or any vulnerable part of the body, can result in serious personal injury. Always observe the following precautions:

ENSURE that children are kept clear and that the sunroof is not obstructed when opening or closing.

DO NOT allow passengers to extend any part of their bodies through the sunroof aperture while the vehicle is moving - injury from flying debris, branches of trees or other obstructions could occur.

Do not open the sunroof if the load on the roof rack will impede its operation.

ALWAYS close the roof when the vehicle is unattended.

NOTE: ENSURE that all adult passengers are familiar with the controls and the potential dangers of operating an electrically operated sunroof.

Sunroof visor

The sunroof visor needs to be opened and closed manually.

Driving with the sunroof open

If, when driving with the sunroof open, unwanted drafts are experienced, open the front fascia air vents, and increase the blower speed if necessary. DO NOT operate the air conditioning.

Sunroof

Sunroof blind

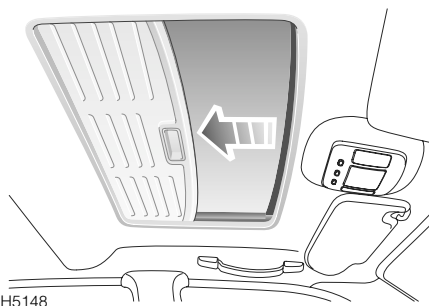

H5148

Pull the sunroof blind across the sunroof aperture to open and close.

Heating & Ventilation

VENTILATION

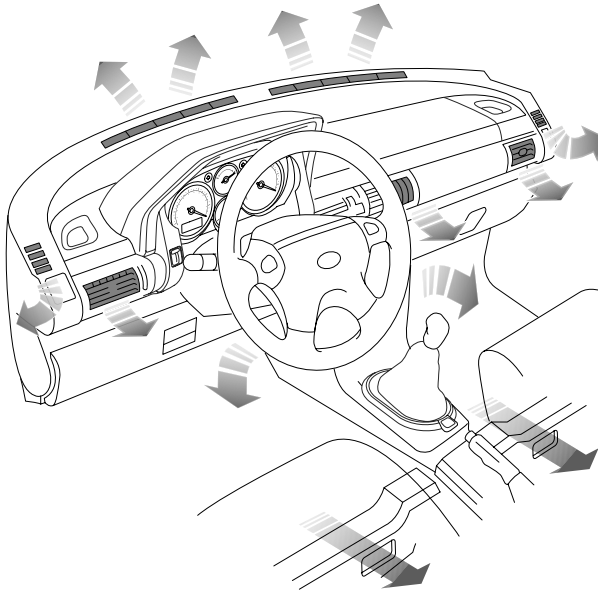

H5213

The ventilation system provides fresh or heated air to the interior of the vehicle from the air intake grille in front of the windscreen.

NOTE: Always keep the air intake grille clear of obstructions such as leaves, snow or ice.

Air outlets are provided to the windscreen, face and feet - the location of the vents is shown in the illustration above. The temperature of the air is controlled by the heater.

Information concerning the operation of the heating and ventilation system, as well as the air conditioning, appears on the pages that follow.

Particle filter*

Particle filters help to keep the vehicle interior free from pollen and dust. To remain fully effective, the filter should be replaced at least every 12 months or 20,000 km, at the time of a main service.

Heating & Ventilation

HEATER CONTROLS

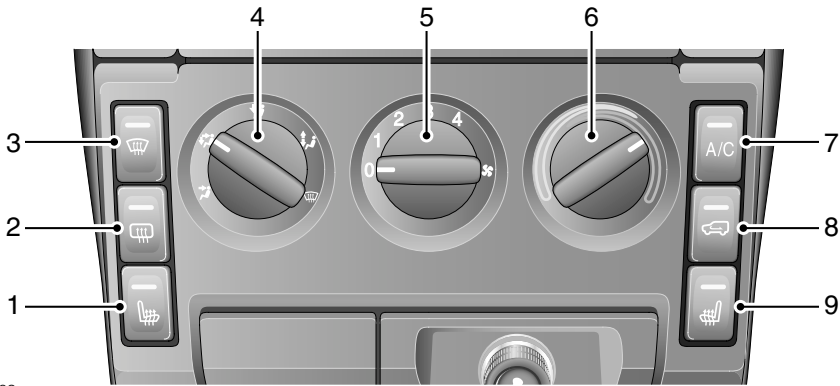

H5063

1 & 9. Heated front seats*

With the starter switch turned on and the engine running, press the switches to operate the heating elements in either the driver's or front passenger seat (the indicator light in the switch illuminates). Press a second time to switch off.

NOTE: The seat heaters will switch off automatically 45 seconds after the starter switch is turned off, or either front door is opened.

The seat heaters are thermostatically controlled and operate intermittently to achieve and then maintain a predetermined temperature between 26°C and 36°C.

NOTE: Owners should be aware that the seat heaters consume considerable power from the battery and for this reason, it is recommended that they are operated only with the engine running.

2. Heated rear window

Press to operate; press a second time to switch off. The indicator light in the switch illuminates whenever the heater is on and extinguishes when the heater is turned off.

NOTE: The heated rear window will operate only with the taildoor fully closed and when the engine is running and will switch off automatically after approximately 15 minutes.

WARNING

DO NOT stick labels over the heating elements, and **DO NOT** scrape or use abrasive materials to clean the inside of the window.

3. Heated front screen*

Press to operate; press a second time to switch off. The indicator light in the switch illuminates whenever the heater is on and extinguishes when the heater is turned off.

NOTE: The front screen heater will operate only when the engine is running and will switch off automatically after approximately 10 minutes.

Heating & Ventilation

4. Air distribution control

Rotate to select air distribution:



Air to face vents
(to ensure best performance, the face level vents must be fully open)



Air to face vents and foot outlets
(to ensure best performance, the face level vents must be fully open)



Air to foot outlets



Air to foot outlets and windscreen
(if the ambient temperature is approximately 5° C or higher, the air conditioning (if fitted) will automatically dehumidify the air to reduce misting).



All air to windscreen
(if the ambient temperature is approximately 5° C or higher, the air conditioning (if fitted) will automatically dehumidify the air to reduce misting).

5. Air blower control

Turn the control clockwise to progressively increase the blower speed.

NOTE: With the control in position '0', the volume of air entering the vehicle is dependent on driving speed alone.

6. Air temperature control

Rotate the control clockwise (towards the RED segments) to increase the air temperature, or anti-clockwise (towards the BLUE) to reduce the temperature.

7. Air conditioning button*

With the engine running, press to operate. The indicator light in the switch illuminates when the air conditioning is switched on.

8. Air recirculation button*

Press to recirculate air inside the vehicle (indicator light illuminates).

The air recirculation mode prevents the heating system from taking in fresh air from outside the vehicle. Instead, the air already inside the vehicle is recirculated, thus preventing the entry of traffic fumes. In cold weather air recirculation also enables warmer air to be used to defrost the windscreen when the engine is still cold.

WARNING

The air recirculation mode can cause the windscreen to mist. If this happens, switch off air recirculation immediately.

Heating & Ventilation

USING YOUR HEATER

Fresh air enters the heater unit through the grille in front of the windscreen and stale air is drawn out through vents in the rear of the vehicle. Ducts beneath the front seats provide heating for rear seat passengers - these must not be obstructed.

The following examples of basic heater settings are intended as a general guide; the air distribution, temperature and blower controls can then be further adjusted to suit your comfort requirements.

Always remember that full heating is not available until the engine has reached its normal operating temperature.

Maximum heating

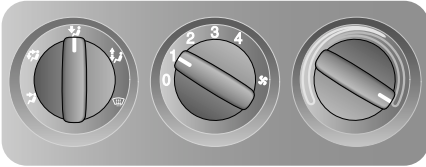

H5065

Petrol engine vehicles: Set the controls as shown, with the blower at the slowest speed (position 1) until the temperature gauge indicates that the engine is warming up - the blower speed can then be increased.

Diesel engine vehicles: Set the controls as shown, but with the blower set to **position 3** until the temperature gauge indicates that the engine is warming up - the blower speed can then be increased if required.

Demisting

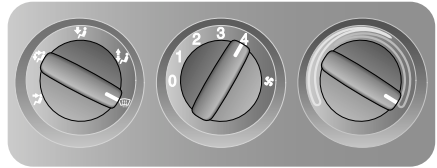

H5066

Set the controls as shown, to obtain the maximum flow of heated air from the windscreen and side window vents. Selection of air conditioning* will also assist in demisting.

On vehicles NOT equipped with air conditioning, opening a window may improve ventilation.

Defrosting

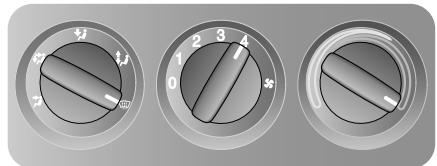
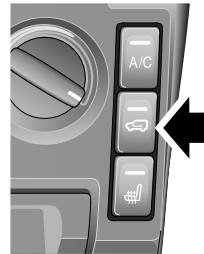

H5067

Set the controls as shown and switch on air recirculation to prevent cold air from being drawn into the vehicle. Turn air recirculation off as soon as the windscreen is clear, to prevent any possibility of the windscreen misting.

Heating & Ventilation

Maximum ventilation

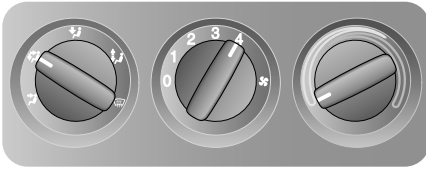

H5069

Set the controls as shown, with the face level vents open. Adjust the blower speed as required.

PTC Heater (Diesel only)

The PTC (Positive Temperature Coefficient) heater is a supplementary heating system that compensates for the relatively low coolant temperatures inherent in the diesel engine.

The PTC heater operates while the engine is running or for a limited time if the ignition is switched on without starting the engine. When the heater blower is selected and the temperature control is turned to the warm/hot range, the PTC heater activates and boosts the air temperature within the vehicle.

NOTE: On vehicles with manual transmission, engine speed may increase when idling, to further enhance the performance of the heater.

Fuel Burning Heater (Diesel only)*

The Fuel Burning Heater (FBH) is an auxiliary heating system that only operates while the engine is running and the ambient temperature is less than 5° C (41° F). At low temperatures, the FBH system maintains the temperature range required for optimum heating within the vehicle. Operation is fully automatic, with no intervention required by the driver.

NOTE: Exhaust emissions from the FBH may be noticed from the front left hand side of the vehicle.

FACE LEVEL VENTS

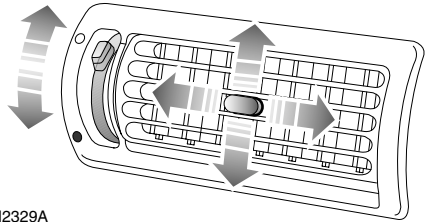

H2329A

Rotate the thumbwheel down to open or up to close the vents. Direct the air flow by moving the control in the centre of the louvres up or down, or from side to side.

To increase output from the centre face vents, shut the outer vents.

When carrying rear seat passengers, use the outer vents for the front seat occupants and use the more powerful centre vents for the rear seat passengers.

On 3-door models, when driving with either the hard or softback removed (or folded in the case of the softback), open all the vents and turn the blower switch on - this will help prevent the ingress of poisonous exhaust fumes.

NOTE: On both 3 and 5-door models, driving with the taildoor or taildoor window open is not recommended because poisonous exhaust fumes will be drawn into the vehicle. (See 'Accommodating long loads', page 38).

Heating & Ventilation

AIR CONDITIONING*

The air conditioner provides additional cooling and also reduces humidity. This can be used to demist windows quickly in damp weather and, when used in conjunction with the heater, makes the interior of the vehicle warm and dry.

NOTE: *In high humidity conditions, slight screen misting may be experienced when the air conditioning is turned on. This is a natural occurrence for most automotive air conditioning systems; it is not a fault with the system and will clear after a few seconds, once the air conditioning is operating.*

Using the air conditioning

The air conditioning can only be used when the engine is running and with the blower switched on. For the air conditioning system to operate efficiently, all windows (and the sunroof/Targa roof) should be closed, and the air intake vents free from ice, snow, leaves and other debris. DO NOT operate the air conditioning with the softback opened, or the hardback removed.

With the engine running, press the 'A/C' button and adjust the air distribution, blower and air temperature controls as required.

NOTE: *The air conditioner will automatically operate when the air distribution control is set to 'All air to windscreen' or 'Air to foot outlets and windscreen', see '4. Air distribution control', page 77.*

Operation of the air conditioning system places an extra load on the engine. In very hot conditions or when the engine is required to work unusually hard (climbing long hills or driving in congested traffic, for example), this could result in high engine temperatures. If the pointer nears the RED zone of the temperature gauge, temporarily turn the air conditioning off until engine temperatures return to normal.

NOTE: *Under extreme conditions, the air conditioning may automatically switch off, to prevent damage to the engine.*

Rapid cooling:

With the engine running press the 'A/C' button, turn the air temperature control to the BLUE segment, select air recirculation and turn the blower switch to '4'. Turn the air distribution control to the face vent setting and fully open all four face level vents. Turn off air recirculation and adjust the blower when the vehicle interior is cool.

NOTE: *In very hot conditions, it may be advisable to fully ventilate the vehicle by opening the windows and sunroof for a while before closing them again and operating the air conditioning.*

Maintaining the air conditioning

The air conditioning system is sealed and major maintenance should only be carried out by a qualified technician. To maintain the system in peak condition, owners should ensure that the system is operated for a short period every week (even during the cold winter months); with the engine at its normal operating temperature, run the air conditioning for at least ten minutes whilst driving at a steady speed.

Surplus water produced by the dehumidifying process is expelled from the system via drain tubes beneath the vehicle. This may result in a small pool of water forming on the road when the vehicle is stationary and is not a cause for concern.

Interior Equipment

COURTESY & MAP READING LIGHTS (5-door models)

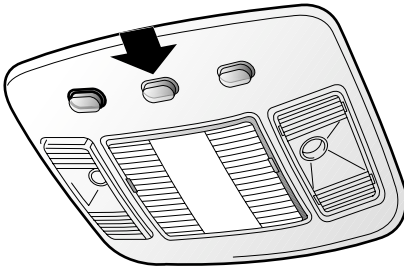

H2352A

Front courtesy and map reading lights

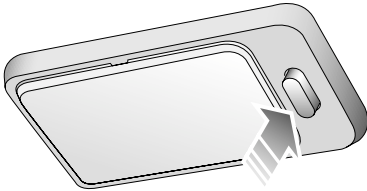

H2593

Rear courtesy light

Press the appropriate switch to illuminate (or extinguish) the lights manually.

The front and rear lights illuminate automatically when the vehicle is unlocked or whenever a door or taildoor is opened, and extinguish approximately 15 seconds after ALL the doors are closed, or as soon as the starter switch is turned on.

If a door or the taildoor remains open for ten minutes or more, a 'time out' function will extinguish the courtesy lights in order to prevent the battery from discharging.

NOTE: If the map reading lights or rear courtesy light are left on after being manually selected, they will NOT extinguish automatically.

The courtesy lights will extinguish when the vehicle is locked.

COURTESY LIGHT (3-door models)

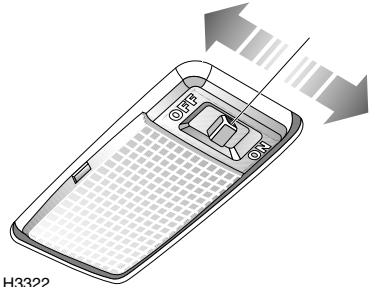

H3322

Switch positions:

- 'OFF' - Light permanently off.
- 'ON' - Light illuminates continuously.

With the switch in the centre position, the interior light illuminates automatically whenever the vehicle is unlocked or when a door or taildoor is opened. The light remains illuminated for 15 seconds after the doors and taildoor are closed, or until the starter switch is turned on.

If a door or the taildoor remains open for ten minutes or more, a 'time out' function will extinguish the courtesy lights in order to prevent the battery from discharging.

NOTE: If the courtesy light is left on after being manually selected, it will NOT extinguish automatically.

The courtesy lights will extinguish when the vehicle is locked.

LUGGAGE COMPARTMENT LIGHT

Illuminates automatically when the taildoor is opened.

Interior Equipment

CLOCK

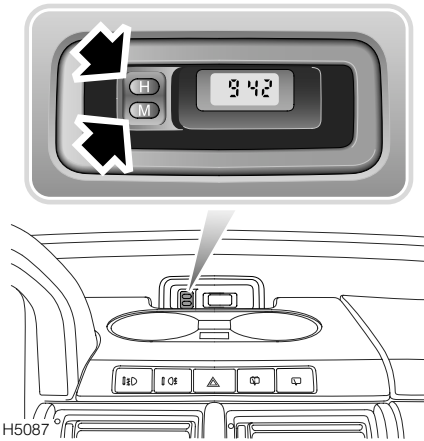

The digital clock display illuminates when the starter switch is turned on and dims for night viewing when the sidelights are switched on.

With the starter switch turned to position 'I', press the hour ('H') and minute ('M') buttons to set the time. If both buttons are pressed together, the display will change between 24 hour and 12 hour displays.

NOTE: If the battery is disconnected, the clock will need to be reset.

GLOVEBOX

WARNING

DO NOT drive with the glovebox open. An open glovebox could cause injury to the front seat passenger in the event of a collision.

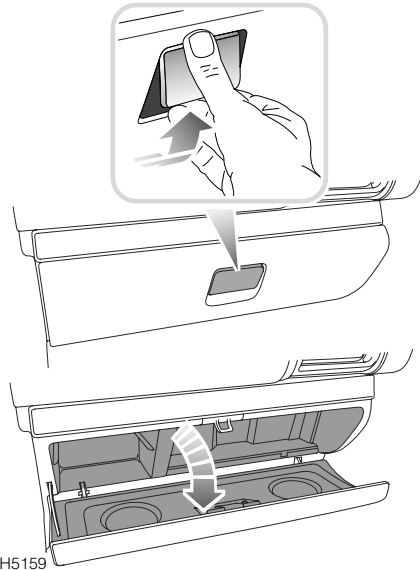

Lift the handle to open the glovebox - the two recesses in the glovebox lid can be used, when the vehicle is stationary, as cup stands.

The left hand compartment in the glovebox can be used to store CD cases.

Glovebox light

Operates automatically when the exterior lights are switched on and the passenger glovebox is opened.

Interior Equipment

DRIVER'S STORAGE AREA

WARNING

DO NOT drive with the storage area open. The storage area lid could cause serious injury in the event of a collision.

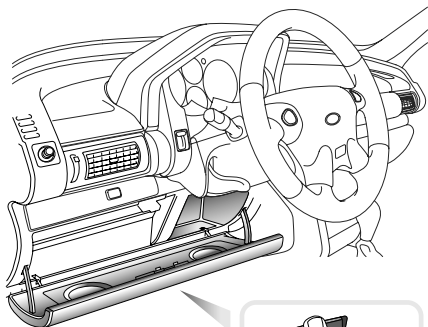

H5161

Lift the handle to open the driver's storage area - when the vehicle is stationary, the two recesses in the lid can be used as cup stands.

The right hand compartment in the storage area can be used to store tape and CD cases.

DRINKS STOWAGE

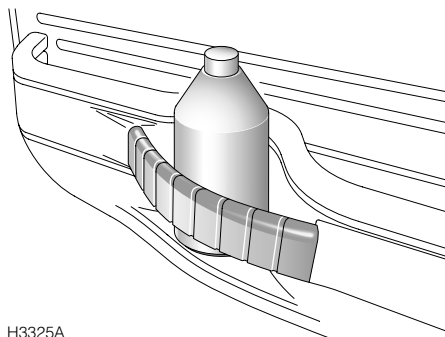

H3325A

The expanding strap fitted to the front door storage compartment on 5-door models can be used to store drink containers securely when driving.

NOTE: Drink containers over 0.5 litre capacity will not be properly secured by the strap.

WARNING

Do not use the strap to store hot drinks.

Interior Equipment

CUP HOLDERS*

WARNING

The driver should not drink and should not use the cup holder while driving.

If the cup holder is retractable, it should be kept closed when not in use.

DO NOT place anything other than suitable drinks containers in the cup holders, because such items may be thrown about in the passenger compartment and possibly injure occupants in the event of an accident or emergency manoeuvre.

Do not carry open-top drink containers in the cup holders while the vehicle is in motion; a spilled hot drink could cause personal injury. Spilled drinks can also damage upholstery, carpeting and electrical components.

Use only for soft containers. DO NOT use to hold cups made of glass, china or hard plastic, as these may cause injury in the event of an accident or emergency manoeuvre. Unopened, sealed containers (drinks cans, for example) are hard objects and may also cause injury.

Front cup holders

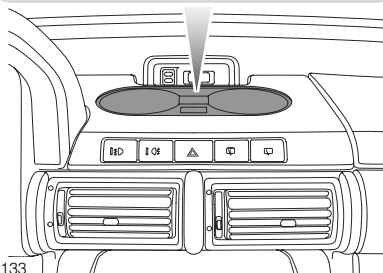
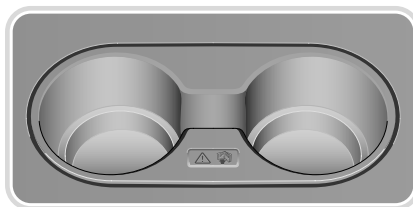

H5133

The front cup holders are located on the top surface of the fascia panel, as illustrated above.

Rear cup holders*

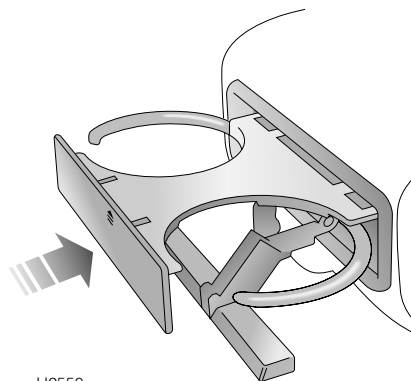

H2550

With the centre armrest lowered, press the front of the cup holder to open. The retaining arms can be adjusted to suit a range of container sizes. Press the front of the cup holder again to close.

Interior Equipment

SUN VISOR

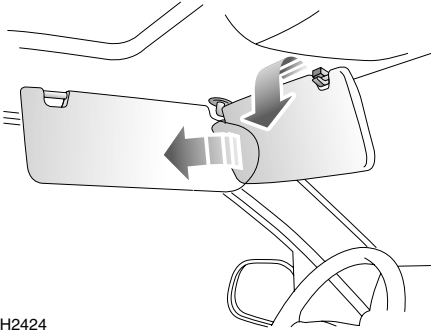

H2424

To shield your eyes from the sun, pull the visor down from the roof; the visor can be used to shield the upper part of the windscreen or the side window as required.

NOTE: On some models, the sun visors are fitted with a vanity mirror on the underside.

SUNGLASSES POCKET (3-door models)

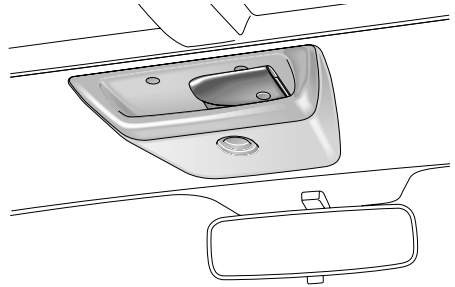

H3326

On 3-door models, there is a pocket designed to be a convenient place to stow sunglasses.

NOTE: Keep sunglasses in a soft case, to prevent scratching.

WARNING

Do not store loose items (tapes, coins etc.) in the sunglasses pocket these could become dangerous projectiles in the event of a sudden stop or collision.

Interior Equipment

ASHTRAY

WARNING

DO NOT use the ashtray for disposing of waste paper or other combustible items.

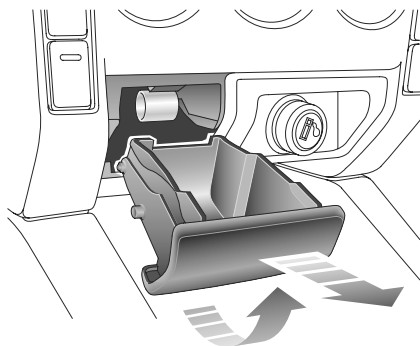

H5200

Front ashtray illustrated

Push the front to open the ashtrays. To remove for emptying; with the ashtray open, carefully pivot the ashtray upwards and withdraw it from the aperture.

To refit the ashtray, partially insert the tray into the aperture, then pivot downwards before pushing the ashtray closed.

CIGAR LIGHTER

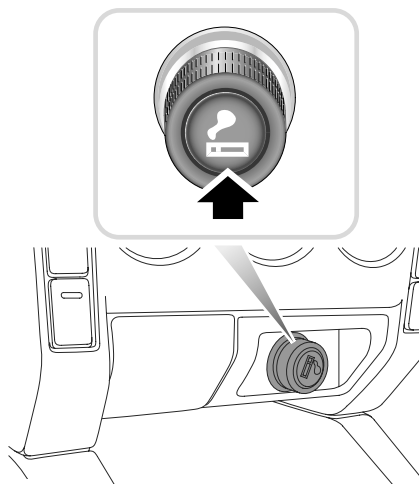

H5201

With the starter switch turned on, press the lighter in to heat up. When it has reached the correct temperature it will partially eject and can then be withdrawn for use.

- ONLY hold the cigar lighter by the handle.

WARNING

DO NOT plug accessories into the cigar lighter socket, unless they are approved for that purpose by Land Rover, as potential damage could occur to the vehicle's electrical systems.

ALWAYS ensure that driving controls are not inhibited by any accessories plugged into the cigar lighter socket.

For your safety and convenience, an auxiliary power socket may be provided in the centre console, above the rear ashtray. See 'AUXILIARY POWER SOCKET*', page 87.

Interior Equipment

AUXILIARY POWER SOCKET*

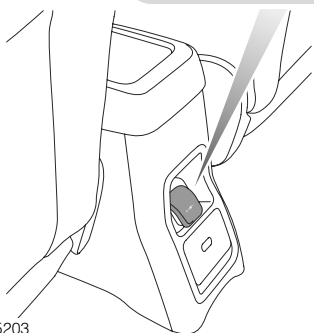

H5203

An auxiliary power socket is mounted in the centre console, above the rear ashtray. This can be used to power Land Rover approved accessories that use a maximum of 180 watts.

Always run the engine during prolonged use of electrical accessories, otherwise the battery may become discharged.

WARNING

NEVER plug non-approved accessories into the power socket - damage to the vehicle's electrical systems could occur.

Rear Door

REAR DOOR

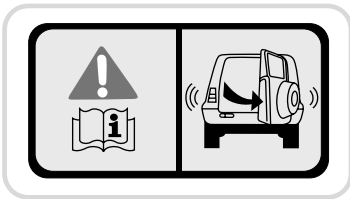
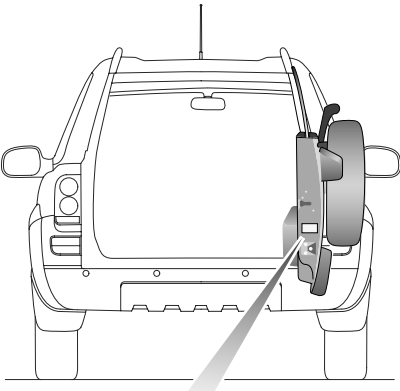

H5158

WARNING

Lights located on the same side of the vehicle as the rear door hinges will be obscured when the door is fully open.

NOTE: Owner should be mindful of and considerate to local traffic/environmental conditions.

Loadspace Cover

LOADSPACE COVER

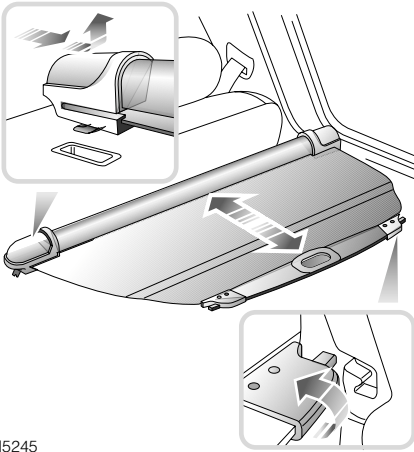

I5245

On 5-door models the rear loadspace can be covered by a spring loaded roller blind, which can be retracted when not in use by detaching the cover from the hooks at the rear of the vehicle (see lower inset).

To remove the loadspace cover:

1. Slide the retracted cover firmly to the right.
2. Lift the left hand end of the cover from its location.
3. Carefully manoeuvre the cover from the rear of the vehicle.

Refitting the loadspace cover is the reverse of the removal procedure.

NOTE: Removal of the loadspace cover may be eased by folding the rear seat backrest forward.

WARNING

DO NOT carry loose items of luggage on top of the loadspace cover - these may obscure vision and could become dangerous projectiles in the event of a sudden stop or collision.

All equipment, luggage or tools carried in the loadspace should be secured to reduce the risk of injury to the driver and passengers in the event of an accident or emergency manoeuvre.

DO NOT store the loadspace cover loose in the vehicle.

In-Car Telephones

IN-CAR TELEPHONES

A fully approved telephone package, including 'hands-free' operation and remote dialling, is available for your vehicle. Please consult your dealer for further information.

For your safety, always note the following precautions before fitting or using an in-car telephone, or any mobile communication equipment.

- Only use an installation kit incorporating an aerial external to the vehicle.
- Ensure that the installation is carried out by a competent installer.

WARNING

Using any hand-held appliance while driving can be dangerous. Always stop the vehicle before making a call and ensure the telephone is switched off while you are driving.

Audio System

AUDIO EQUIPMENT

NOTE: Full operating instructions for any audio equipment fitted as standard to your vehicle, are contained in the 'Audio System' book in the literature pack.

CD autochanger*

The CD autochanger is located under the front passenger seat. Full operating instructions are contained in the 'Audio System' book in the literature pack.

RADIO AERIAL

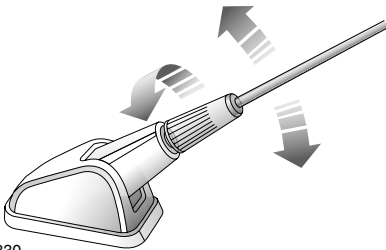

H2330

Your vehicle is equipped with a detachable mast aerial, mounted on the roof.

NOTE: ALWAYS unscrew and remove the aerial before entering an automatic car wash.

Aerial height

Always check the available headroom and, if necessary, adjust the angle of the aerial (see illustration) before entering or leaving a garage or car park with insufficient headroom.

REMOTE AUDIO CONTROLS

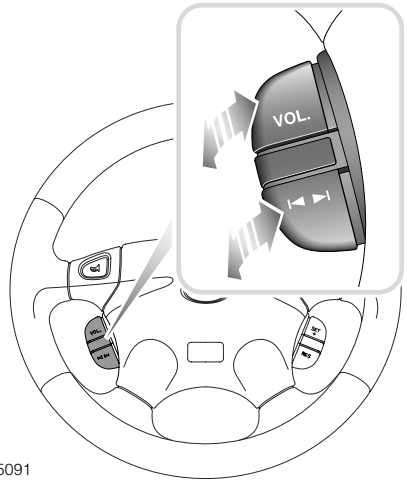

H5091

Volume control

Lift or press down to increase or decrease volume.

Search control

Lift or press down to search for the next or previous radio station on the selected waveband.

During CD play, lift the control to move forward to the next track, or press down to return to the start of the current track. Operate the control repeatedly to move forward or back through several tracks at a time.



Driving & Operating

Starting & Driving

| | |
|------------------------------------|-----|
| STARTER SWITCH | 95 |
| STARTING - Petrol models | 96 |
| STARTING - Diesel models | 97 |
| DRIVING | 98 |
| FUEL ECONOMY | 99 |
| EMISSION CONTROL SYSTEM | 100 |

Catalytic Converter

| | |
|-------------------------------|-----|
| CATALYTIC CONVERTER | 101 |
|-------------------------------|-----|

Fuel System

| | |
|--|-----|
| TYPE OF FUEL | 103 |
| SAFETY ON THE FORECOURT | 104 |
| FUEL FILLER | 104 |
| FUEL FILLING | 104 |
| EMPTY FUEL TANK | 105 |
| FUEL CUT-OFF SWITCH (Petrol engine vehicles only) | 106 |

Manual Gearbox

| | |
|----------------------|-----|
| GEAR LEVER | 107 |
|----------------------|-----|

Automatic Gearbox

| | |
|--|-----|
| CommandShift® TRANSMISSION | 108 |
| GEAR SELECTOR LEVER | 108 |
| USING AN AUTOMATIC GEARBOX | 111 |
| AUTOMATICALLY SELECTED MODES | 112 |

Hill Descent Control

| | |
|--------------------------------|-----|
| HILL DESCENT CONTROL | 113 |
|--------------------------------|-----|

Cruise Control

| | |
|--------------------------|-----|
| CRUISE CONTROL | 116 |
|--------------------------|-----|

Brakes

| | |
|----------------------------|-----|
| FOOT BRAKE | 118 |
| HANDBRAKE | 119 |
| ANTI-LOCK BRAKES | 120 |

Traction Control

| | |
|---------------------------------------|-----|
| ELECTRONIC TRACTION CONTROL | 122 |
|---------------------------------------|-----|

Parking Aid System

| | |
|--|-----|
| USING THE PARKING AID SYSTEM | 123 |
|--|-----|

Targa Roof

TARGA ROOF 125

Softback

FOLDING AND UNFOLDING THE SOFTBACK . . 127

Hardback

REMOVING AND FITTING THE HARDBACK . . . 138

Fitting 140

Roof Bars

REMOVING AND FITTING THE ROOF BARS . . . 142

Taildoor

OPENING AND CLOSING 145

Load Carrying

LOADSPACE SIDE POCKETS 146

LUGGAGE ANCHOR POINTS..... 146

STOWAGE BOX..... 146

VEHICLE LOADING..... 147

ROOF RACK 147

Towing

TOWING 149

TOW BARS 151

Starting & Driving

STARTER SWITCH

The starter switch is located to the right of the steering column, and uses the following sequence of key positions to operate the steering lock, electrical circuits and starter motor:

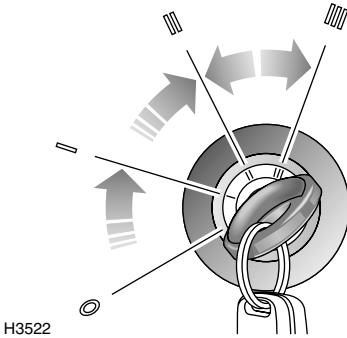

Position '0'

- Steering locked (if key is removed).
- Most lighting circuits are operational, including: sidelights, headlights and hazard warning lights.

Position '1'

- Steering unlocked.
- Clock, radio/cassette player and cigar lighter can now be operated.

Position 'II'

- All instruments, warning lights and electrical circuits are operational.

Position 'III'

- Starter motor operates.
Release the key immediately the engine starts (the key will automatically return to position 'II'). Note that operation of position 'I' electrical functions will be interrupted during engine cranking.

NOTE: On automatic models gear selector position 'P' or 'N' must be selected before the engine will start.

NOTE: When the starter switch is at position 'II', a short, low pitched 'buzz' may be heard; this is the ABS system priming and is no cause for concern. The instruments and warning lights will also prime.

Starting & Driving

STARTING - Petrol models

WARNING

Never start or leave the engine running in an unventilated building - exhaust gases are poisonous and contain carbon monoxide, which can cause unconsciousness and may even be fatal.

Before starting the engine and driving, ENSURE you are familiar with the precautions shown under 'CATALYTIC CONVERTER *', page 101.

In particular, you should be aware that if the engine fails to start, continued use of the starter may result in unburnt fuel damaging the catalytic converter.

1. Check that the handbrake is applied and that the gear lever is in neutral ('P' or 'N' for automatic transmission).
2. Switch off all unnecessary electrical equipment (including the air conditioning).
3. Turn the starter switch to position 'III' to operate the starter motor and RELEASE THE KEY as soon as the engine is running.

DO NOT press the accelerator pedal while starting and DO NOT operate the starter for longer than 15 seconds. If the engine fails to start, switch off and wait for at least 10 seconds before trying again.

NOTE: Continued use of the starter will not only discharge the battery, but may cause damage to the starter motor and the catalytic converter.

NOTE: The battery charging, oil pressure and engine malfunction indicator warning lights should extinguish as soon as the engine is running.

In cold weather, or when the battery is in a low state of charge, on manual gearbox vehicles depress the clutch pedal while starting and hold it down until the engine is running. This will reduce the load on the battery.

What to do if the engine fails to start, or starts but will not continue running:

- Press the accelerator pedal half way down while operating the starter. DO NOT operate the starter for more than 15 seconds and release the accelerator as soon as the engine fires.
- If the engine still fails to start, operate the starter again, this time FULLY depressing the accelerator pedal to clear the engine of excess fuel. Ensure the starter motor is not operated for more than 15 seconds and release the accelerator pedal as soon as the engine has started.
- DO NOT pump the accelerator pedal during starting.

NOTE: If starting the vehicle in cold weather at high altitude (above 2,400 m), adopt the above procedure as normal practice.

Cold climates

At temperatures down to -26°C, the engine should start within 5 to 8 seconds. Below this temperature, engine cranking times will increase significantly and the starter motor may need to be operated continuously for as long as 30 seconds before the engine will start. For this reason, ensure that all non-essential electrical equipment is switched off.

In very cold climates the oil pressure warning light may take several seconds to extinguish.

Cylinder block heaters

Only approved cylinder block heaters restricted to a maximum of 400 W should be used. Cylinder block heaters that exceed this output may damage the emission control components.

Starting & Driving

Automatic gearbox vehicles

After starting, ensure that the handbrake and foot brake are firmly applied and the accelerator pedal is not depressed while moving the gear selector lever from 'N' or 'P', otherwise, the vehicle may move immediately the selector lever is moved to one of the drive positions (1, 2, 4, D or R). This is particularly important when the engine is cold, because the engine will be idling at a faster speed than normal.

NOTE: *The selector lever cannot be moved from 'P' to a drive position while the engine is running, unless the brake pedal is applied.*

STARTING - Diesel models

WARNING

Never start or leave the engine running in an unventilated building - exhaust gases are poisonous and contain carbon monoxide, which can cause unconsciousness and may even be fatal.

Before starting the engine and driving, ENSURE you are familiar with the precautions shown under 'CATALYTIC CONVERTER *', page 101.

In particular, you should be aware that if the engine fails to start, continued use of the starter may result in unburnt fuel damaging the catalytic converter.

1. Check that the handbrake is applied and that the gear lever is in neutral ('P' or 'N' for automatic transmission).
2. Switch off all unnecessary electrical equipment (including the air conditioning).
3. Insert the starter key and turn the switch to position 'II'. Wait until the glow plug warning light extinguishes.

NOTE: *The waiting time will vary according to the engine coolant temperature (when the engine is hot, the glow plug warning light will extinguish almost immediately).*

4. Turn the key to position 'III' to operate the starter motor. DO NOT press the accelerator pedal while starting. RELEASE THE KEY as soon as the engine is running.

If the engine stalls or fails to start, you MUST return the starter switch to position 'O' before attempting to restart; the engine will not start by turning the starter switch from position 'II'.

In temperate climates DO NOT operate the starter for longer than 10 seconds. If the engine fails to start, switch off and wait 10 seconds before re-using the starter.

NOTE: *Continued use of the starter will not only discharge the battery, but may cause damage to the starter motor.*

NOTE: *The battery charging and oil pressure warning lights should extinguish as soon as the engine is running.*

In cold weather, or when the battery is in a low state of charge, on manual gearbox vehicles depress the clutch pedal while starting and hold it down until the engine is running. This will reduce the load on the battery.

NOTE: *The diesel engine must not be run above idle speed until the oil pressure warning light extinguishes. This will ensure that the engine and turbo-charger bearings are properly lubricated before being run at speed.*

NOTE: *Similarly, ALWAYS allow the engine to idle for 10 seconds before switching off.*

Starting & Driving

Cold climates

The engine of your Freelander is fitted with an advanced 'drive by wire' engine management system. This is designed to optimise the vehicle's cold start behaviour - pressing the accelerator pedal has no effect on starting performance.

At temperatures down to -26°C (-15°F), the engine should start within 5 to 8 seconds. Below this temperature, engine cranking times will increase significantly and the starter motor may need to be operated continuously for as long as 30 seconds before the engine will start. For this reason, ensure that all non-essential electrical equipment is switched off.

In very cold climates the oil pressure warning light may take several seconds to extinguish.

Cylinder block heaters

Only approved cylinder block heaters restricted to a maximum of 400 W should be used.

Cylinder block heaters that exceed this output may damage the emission control components.

Automatic gearbox vehicles

After starting, ensure that the handbrake and foot brake are firmly applied and the accelerator pedal is not depressed while moving the gear selector lever from 'N' or 'P', otherwise, the vehicle may move immediately the selector lever is moved to one of the drive positions (1, 2, 4, D or R). This is particularly important when the engine is cold, because the engine will be idling at a faster speed than normal.

NOTE: *The selector lever cannot be moved from 'P' to a drive position while the engine is running, unless the brake pedal is applied.*

DRIVING

IMPORTANT INFORMATION

Vehicle stability

Your vehicle has a higher ground clearance and, hence, a higher centre of gravity than ordinary passenger cars to enable the vehicle to perform in a wide variety of different off-road applications. An advantage of the higher ground clearance is a better view of the road, allowing the driver to more easily anticipate problems. Inexperienced drivers should take additional care, remembering that your vehicle is not designed for cornering at the same speeds as conventional passenger cars, any more than a low slung sports car is designed to perform satisfactorily in off-road conditions. As with other vehicles of this type, failure to operate your vehicle correctly may result in loss of control or even vehicle rollover.

Vehicle height

The overall height of your vehicle exceeds that of ordinary passenger cars. Always be aware of the height of your vehicle and check the available headroom before driving through low entrances. This is particularly important if the vehicle is fitted with a roof rack or if the sunroof is tilted open.

Instruments and warning lights

Before driving it is important to fully understand the function of the instruments and warning lights.

NOTE: *Red warning lights are of particular importance; illumination indicates that a safety-related problem or potentially serious mechanical fault exists. If a red light illuminates, always stop the vehicle and seek qualified assistance before continuing.*

Starting & Driving

Warming-up

DO NOT warm-up the engine by allowing it to idle at a slow speed.

In the interests of fuel economy, it is advisable to drive the vehicle straight away, remembering that harsh acceleration and labouring the engine before the normal operating temperature has been reached can damage the engine.

Parking

After bringing the vehicle to a stop, ALWAYS apply the handbrake and select neutral ('P' for vehicles with automatic transmission), before releasing the foot brake and switching off the engine.

WARNING

Cooling fans may continue to operate after the engine is switched off. When the engine is hot, the cooling fans may also COMMENCE operating after the engine is switched off and continue operating for up to 8 minutes. Keep clear of all fans while working in the engine compartment.

Running-in

Proper running-in will have a direct bearing on the reliability and smooth running of your vehicle throughout its life.

In particular, the engine, gearbox, brakes and tyres need time to 'bed-in' and adjust to the demands of everyday motoring. During the first 1000 km, it is essential to drive with consideration for the running-in process and heed the following advice:

- LIMIT maximum road speed to 110 km/h or 3,000 rev/min. Initially, drive the vehicle on a light throttle and only increase engine speeds gradually once the running-in distance has been completed.

- DO NOT operate at full throttle or allow the engine to labour in any gear.
- AVOID fast acceleration and heavy braking except in emergencies.

After the running-in distance has been completed, engine speeds may be gradually increased.

FUEL ECONOMY

Fuel consumption is influenced by two major factors:

- How your vehicle is maintained.
- How you drive your vehicle.

To obtain optimum fuel economy, it is essential that your vehicle is maintained in accordance with the manufacturer's service schedule.

Items such as the condition of the air cleaner element, tyre pressures and wheel alignment will have a significant effect on fuel consumption. But, above all, the way in which you drive is most important. The following hints may help you to obtain better value from your motoring:

- Avoid unnecessary, short, start-stop journeys.
- Avoid fast starts by accelerating gently and smoothly from rest.
- Do not drive in the lower gears for longer than necessary.
- Decelerate gently and avoid sudden and heavy braking.
- Anticipate obstructions and adjust your speed accordingly well in advance.
- When stationary in traffic, select neutral to improve fuel economy and air conditioning performance.

Starting & Driving

EMISSION CONTROL SYSTEM

WARNING

Exhaust fumes contain poisonous substances which can cause unconsciousness and may even be fatal.

- *DO NOT inhale exhaust gases.*
 - *DO NOT start or leave the engine running in an enclosed unventilated area, or drive with the taildoor open.*
 - *DO NOT modify the exhaust system from the original design.*
 - *ALWAYS repair exhaust system leaks immediately.*
 - *If you think exhaust fumes are entering the vehicle have the cause determined and corrected immediately.*
-

Land Rover vehicles are fitted with emission and evaporative control equipment necessary to meet a number of territorial requirements.

In many countries it is against the law for vehicle owners to modify or tamper with emission control equipment, or to sanction the unauthorised replacement or modification of this equipment. In such cases the vehicle owner and the repairer may both be liable for legal penalties.

It is important to remember that all Land Rover Dealers/Authorised Repairers are properly equipped to perform repairs and to maintain the emission control system on your Freelander.

Catalytic Converter

CATALYTIC CONVERTER *

The exhaust system on your vehicle incorporates a catalytic converter, which converts poisonous exhaust emissions from the engine into environmentally less harmful gases.

WARNING

Severe damage to the catalytic converter could occur if the engine is stopped for any length of time when being driven through water whose level is above the exhaust tailpipe.

Catalytic converters can be easily damaged through improper use, particularly if the wrong fuel is used, or if an engine misfire occurs. For this reason it is VERY IMPORTANT that you heed the precautions which follow.

Fuel

ONLY use fuel recommended for your vehicle, see 'TYPE OF FUEL', page 103.

Starting the engine

- DO NOT continue to operate the starter after a few failed attempts (unburnt fuel may be drawn into the exhaust system, thereby poisoning the catalyst), and do not attempt to clear a misfire by pressing the accelerator pedal - seek qualified assistance.
- When starting a COLD engine, DO NOT drive if a misfire is suspected and do not attempt to clear a misfire by pressing the accelerator - seek qualified assistance.
- Do not attempt to push or tow-start the vehicle.

Driving

- If a misfire is suspected, or the vehicle lacks power while driving, then provided the engine has reached its normal operating temperature, you may drive SLOWLY (at risk of catalyst damage) to a Land Rover Dealer/Authorised Repairer for assistance.
- NEVER allow the vehicle to run out of fuel (the resultant misfire could damage the catalyst).
- Consult your Dealer/Authorised Repairer if your vehicle is burning excessive oil (blue smoke from the exhaust), as this will progressively reduce catalyst efficiency.
- On rough terrain do not allow the underside of the vehicle to be subjected to heavy impacts which could damage the catalytic converter.
- DO NOT overload or excessively 'rev' the engine.
- DO NOT switch off the engine when the vehicle is in motion with a drive gear selected.

WARNING

Exhaust system temperatures can be extremely high - DO NOT park on ground where combustible materials such as dry grass or leaves could come into contact with the exhaust system - in dry weather a fire could result.

Catalytic Converter

Vehicle maintenance

- Any engine misfire, loss of engine performance or engine run-on, could seriously damage the catalytic converter. For this reason, it is vital that unqualified persons do not tamper with the engine, and that regular systematic maintenance is carried out by a Land Rover Dealer/Authorised Repairer.
- Petrol models - DO NOT run the engine with a spark plug or HT lead removed, or use any device that requires an insert into a spark plug.

Fuel System

TYPE OF FUEL

Petrol engine vehicles

WARNING

On vehicles fitted with a catalytic converter, serious damage to the catalyst will occur if LEADED fuel is used!

Fuel specification: See 'ENGINES', page 236.

The RON value (octane rating) and type of petroleum (unleaded or leaded), available at garage forecourts will vary in different parts of the world.

For example, in most European countries 95 RON unleaded fuel is readily available, but in some parts of the world fuel supplies may be limited to leaded or lower octane fuels only.

During manufacture, engines are tuned to suit the fuel supplies commonly available in the market for which the vehicle is destined.

However, if a vehicle is later exported to a different country, or is used to travel between different territories, the owner should be aware that the available fuel supplies may not be compatible with the engine specification. If in doubt, consult a Dealer/Authorised Repairer for advice.

IN AN EMERGENCY (and only if the correct fuel is unavailable), lower octane rated fuel can be used for very limited periods of moderate, or low speed motoring, provided engine 'knocking' does not occur.

NOTE: An occasional, light, engine knock while accelerating or climbing hills is acceptable.

Diesel engine vehicles

WARNING

ONLY use diesel fuel. DO NOT use other fuels (kerosene, petrol or alcohol, for example) as damage to engine components will occur.

WARNING

This vehicle is NOT compatible with 'Bio-diesel' fuel.

Fuel specification: See 'ENGINES', page 236.

NOTE: On diesel models, the word 'Diesel' is printed on the fuel gauge.

The quality of diesel fuel (Derv) can vary in different countries and only clean, good quality fuel should be used. It is important that the sulphur content of diesel fuel does not exceed 0.3%. In Europe all supplies should be within this limit, but in other parts of the world, you should check with your supplier.

Ensure that the fuel filter element is changed at the recommended service intervals.

NOTE: If loss of engine performance due to the use of low quality fuel is experienced, consult your Dealer/Authorised Repairer.

WARNING

DO NOT add petrol to the fuel tank of a diesel engine vehicle, as substantial damage to the engine and associated components will occur. Land Rover cannot be held responsible for any costs incurred if such an error is made.

WARNING

If the fuel tank is accidentally filled with petrol it is ESSENTIAL that you contact your Dealer/Authorised Repairer BEFORE attempting to start the engine.

Fuel System

SAFETY ON THE FORECOURT

WARNING

Petroleum gases are highly flammable and, in confined spaces, are also extremely explosive.

Always take sensible precautions when refuelling:

- Switch off the engine.
- Do not smoke or use a naked flame or light.
- Take care not to spill fuel.
- Do not overfill the tank.

FUEL FILLER

WARNING

Use only the recommended fuel! Serious damage to the catalytic converter will occur if the wrong fuel is used.

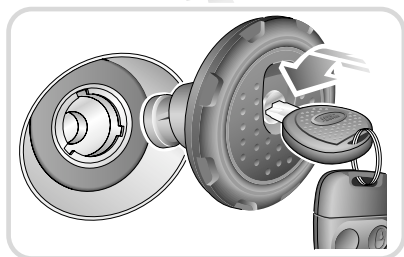
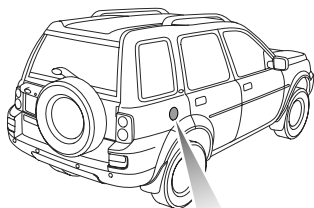

H5114

The fuel filler is located in the rear right-hand wing. Insert the key in the lock, turn it anti-clockwise and allow any pressure inside the tank to escape, before removing the cap.

NOTE: *The key cannot be removed from the filler cap unless the cap is correctly positioned in the filler neck.*

FUEL FILLING

WARNING

DO NOT attempt to fill the tank to its maximum capacity. If the vehicle is to be parked on a slope, in direct sunlight, or high ambient temperature, expansion of the fuel could cause spillage.

Filling station pumps are equipped with automatic cut-off sensing to avoid fuel spillage. Fill the tank SLOWLY until the filler nozzle automatically cuts-off the supply. DO NOT attempt to fill the tank beyond this point or spillage could result due to expansion of the fuel.

Petrol engine vehicles

On vehicles designed to use unleaded fuel, the fuel filler neck will accept ONLY a narrow filler nozzle of the type found on pumps that deliver UNLEADED fuel. A flap lies across the filler neck; insert the nozzle sufficiently to fully open the flap before filling. On vehicles designed for markets where only LEADED fuel is available, the fuel filler neck will be wide enough to accommodate a leaded fuel filler nozzle.

Diesel engine vehicles

The diesel pumps on garage forecourts fill at a maximum of 45 litres per minute. Use of commercial vehicle diesel pumps with a higher fill rate, may result in premature pump cut-off and fuel spillage.

Fuel System

Filling difficulties

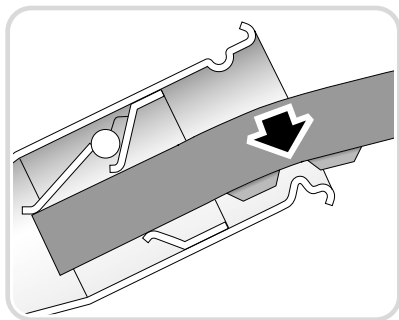
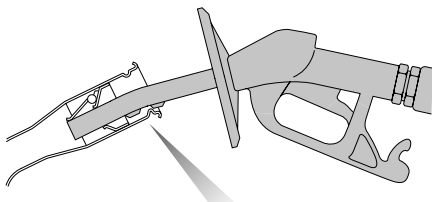

H5116

The fuel delivery rate of filling station pumps can vary significantly from one garage forecourt to another. This, coupled with the fact that modern pumps are equipped with a sensor which automatically cuts off the supply as soon as turbulence is detected in the upper part of the vehicle's filler neck, could result in isolated fuel filling problems.

If individual owners experience difficulty, the operating tips below may be useful:

- Fully insert the filler gun, then withdraw the gun up to the first ridge on the underside of the nozzle.
- Hold the filler gun with the trigger directly below the nozzle. Twisting the gun to either side is unlikely to ease the filling process.
- Fill the tank slowly - DO NOT fully squeeze the trigger.

EMPTY FUEL TANK

Petrol engine vehicles

In the case of petrol engine vehicles equipped with a catalytic converter, running the fuel tank dry could create an engine misfire capable of damaging the catalytic converter. **DO NOT RUN THE FUEL TANK DRY!** Contact your Land Rover Dealer/Authorised Repairer before attempting to start the engine.

Diesel engine vehicles

The fuel system will prime automatically and the engine can be started.

Fuel System

FUEL CUT-OFF SWITCH (Petrol engine vehicles only)

WARNING

ALWAYS check for fuel leaks before resetting the switch!

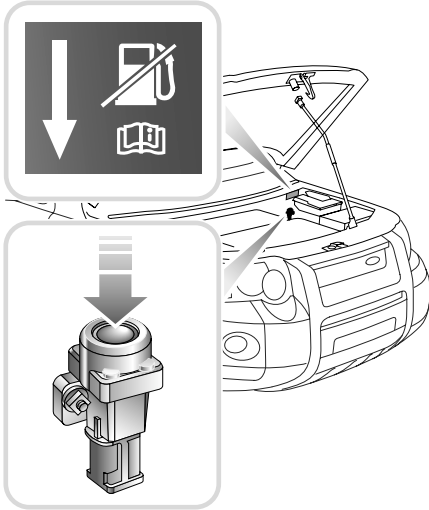

H5033

The fuel cut-off switch is a safety device which, in the event of a collision or sudden impact, automatically cuts off the fuel supply to the engine.

The switch is located inside the engine compartment on the left hand side, beneath, and to the rear of, the engine compartment fuse box. If the switch has been activated, it must be reset by pressing the rubber top (arrowed in illustration) before the engine can be restarted.

See also '*DOOR LOCKING CUT-OFF SWITCH*', page 33.

Manual Gearbox

GEAR LEVER

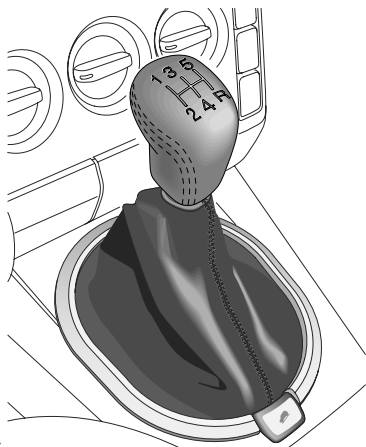

H5217

The gear positions are shown on the gear lever knob. Note that when the gearbox is in neutral, the gear lever is spring-loaded to lie naturally between third and fourth gear positions.

Selecting reverse

Before selecting reverse gear, ensure the vehicle is stationary; then, fully depress the clutch pedal and pause briefly before moving the gear lever into position.

WARNING

Do not select reverse gear unless the vehicle is stationary.

DO NOT attempt to start the engine with the vehicle in gear. The engine must ONLY be started with the main gear lever in neutral and the handbrake applied.

Hill descent control

Hill descent control can only be activated when the vehicle is in 1st or reverse gear.

For further information, see 'HILL DESCENT CONTROL', page 113.

Precautions while driving

- DO NOT rest your hand on the gear lever while driving - pressure from your hand may cause premature wear to the gear selector mechanism.
- DO NOT use the clutch pedal as a foot rest. To prevent unnecessary wear, always keep the left foot clear of the clutch pedal except when changing gear.
- DO NOT hold the vehicle stationary on a hill by slipping the clutch. This will wear out the clutch. Always use the handbrake.

Automatic Gearbox

CommandShift® TRANSMISSION

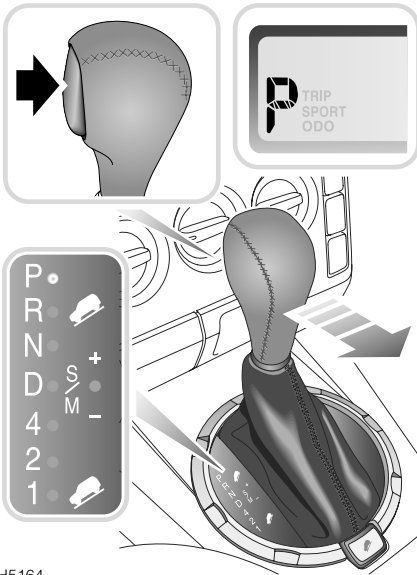

H5164

The transmission provides both automatic and manual operation of the gears.

Automatic operation

The transmission is naturally in automatic mode. With the engine started, gear selection can be made by moving the selector backward or forward to the appropriate position in a similar manner to other automatic gearboxes.

GEAR SELECTOR LEVER

Selector release button

The gearbox is fitted with a locking mechanism, designed to minimise the risk of accidental selection of the 'P' (Park) and 'R' (Reverse) positions.

The selector release button (arrowed in illustration) must be pressed while selecting 'R' from 'P', and also to enable the lever to be moved between the 'N' and 'R' positions.

The selector release button must also be pressed when selecting '2'.

NOTE: With the engine running, or the starter switch in position II, the selector lever cannot be moved from 'P' (Park) into a drive position unless the foot brake is applied.

WARNING

DO NOT select 'P' or 'R' if the vehicle is moving.

DO NOT select a forward drive gear when the vehicle is moving backwards.

To prevent transmission wear, keep engine speed as low as possible when moving the selector between 'R' and a forward gear.

Automatic Gearbox

Selector lever positions

An indicator light on the selector panel and a number or letter on the digital display in the instrument panel, identify the selected gear position.

'P' - Park:

This position mechanically locks the transmission and should be selected before switching the engine off. To avoid transmission damage, ensure the vehicle is completely stationary, with the handbrake applied, before selecting 'P'.

The selector release button **MUST** be pressed, in order to move the selector lever into, or out of, the Park position.

'R' - Reverse:

Before selecting reverse, ensure the vehicle is stationary, with the brakes applied. Press the selector release button in order to move the selector lever into Reverse.

With the selector lever in the 'R' position, Hill Descent Control can be selected (see '*HILL DESCENT CONTROL*', page 113).

'N' - Neutral:

Select neutral when the vehicle is stationary and the engine is required to idle for a brief period (at traffic lights, for example). In neutral, the transmission is not locked, so the handbrake must be applied whenever 'N' is selected.

Press the selector release button to move from neutral to reverse.

'D' - Drive:

Select for all normal driving; full automatic gear changing occurs on all five forward gears, according to road speed and accelerator position.

'4' (1st, 2nd, 3rd and 4th gears):

Automatic gear changing is limited to the lower four gears only; use this position for town driving and on winding country roads.

'2' (1st and 2nd gears):

Automatic gear changing is limited to the first and second gears only; use when driving up steep gradients, for negotiating very narrow twisting roads and for most 'Off-road' driving. This position also provides moderate engine braking when descending slopes.

The selector release button **MUST** be pressed in order to move the selector lever into, or out of, position '2'.

'1' (1st gear only):

Use on very severe gradients. With the selector in this position, Hill Descent Control can be selected (see '*HILL DESCENT CONTROL*', page 113).

Automatic Gearbox

Sport mode

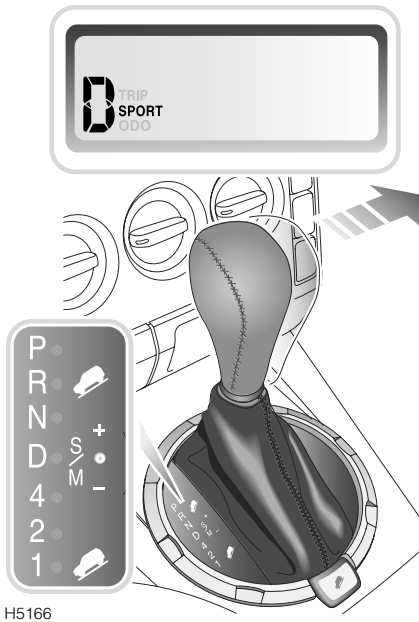

In Sport mode, full automatic progression through the gear ratios is retained. By selecting Sport mode however, the power transmitted to the road wheels is increased, resulting in improved acceleration. Engine revs are higher in all driving conditions, making the vehicle more responsive to driver commands.

To select Sport mode, move the gear lever sideways across the gate, from the 'D' (Drive) position towards the right hand side of the vehicle. The word 'SPORT' will appear in the digital display and an indicator light on the selector panel will confirm the selected mode as 'S/M'.

Sport mode can be deselected at any time, by returning the lever to the 'D' position.

Manual gear selection

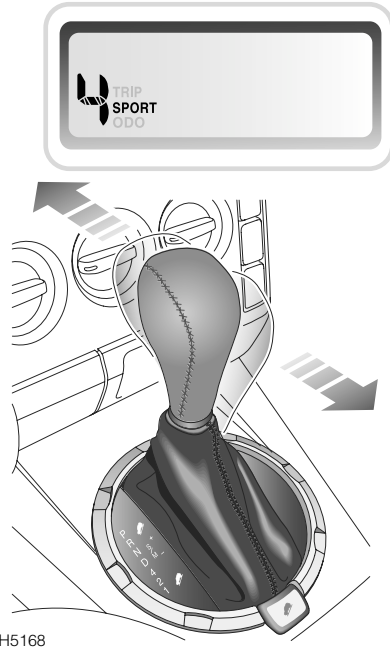

There are five predetermined gear ratios, all of which can be selected sequentially by a single forward or rearward movement of the gear selector lever, as follows:

1. With 'D' (Drive) selected, move the gear selector lever sideways from the 'D' position towards the right hand side of the vehicle (this is the same as selecting Sport mode). The gearbox will remain in Sport mode until the gear selector is moved forward or back (see '3' below).
2. The transmission then automatically selects the ratio most appropriate to the vehicle's road speed and accelerator depression.

Automatic Gearbox

3. A single forward movement of the selector lever will change the transmission to a higher gear, while rearward movement of the lever will change down to a lower gear. Repeated forward or rearward movements of the lever can be made until the desired gear ratio has been selected (the selected gear will be indicated in the digital display in the instrument panel).
4. To deselect manual mode, simply move the selector lever sideways, back to the 'D' position. Automatic gear changing will then resume.

NOTE: *When coming to a halt with manual selected, the vehicle will remain in 2nd gear. When starting again, 'kick down' can be used to select 1st gear if necessary.*

USING AN AUTOMATIC GEARBOX

The following information is particularly important for drivers who are unfamiliar with the techniques required to drive vehicles with automatic transmission.

Starting

The engine can only be started with the selector lever in the 'P' (Park) or 'N' (Neutral) positions.

- ALWAYS apply the handbrake and foot brake before starting the engine.
- KEEP THE BRAKES APPLIED while moving the selector lever into a drive position (the selector lever cannot be moved from the 'P' position unless the foot brake is applied).
- DO NOT 'rev' the engine or allow it to run above normal idle speed while selecting 'D' or 'R', or while the vehicle is stationary with any gear selected.
- ALWAYS keep the brakes applied until you are ready to move off - remember, once a drive gear has been selected, an 'automatic' will tend to creep forward (or backward if reverse is selected).
- DO NOT allow the vehicle to remain stationary for any length of time with a drive gear selected and the engine running (always select 'N' if the engine is to idle for a prolonged period).

WARNING

Vehicles fitted with automatic transmission CANNOT be 'push' or 'tow' started.

Driving

When driving, the transmission will automatically adjust to the most appropriate ratio, according to accelerator position, vehicle speed and terrain (whether the vehicle is driving uphill, downhill or on the flat).

Automatic Gearbox

Gear change speeds

With 'D' selected, the road speeds at which gear changes take place will vary according to the position of the accelerator pedal: minimum acceleration will result in gear changes at low road speeds, while larger throttle openings will cause the gearbox to delay gear changes until faster road speeds have been reached (thereby increasing the rate of acceleration).

With practice, gear changes can be made to occur at a wide range of road speeds depending on the accelerator position.

'Kick-down'

To provide rapid acceleration for overtaking, push the accelerator pedal to the full extent of its travel in a single, quick movement (this is known as 'kick-down'). Up to a certain speed, this will cause an immediate downshift to the lowest appropriate gear, followed by rapid acceleration. Once the pedal is relaxed, normal gear change speeds will resume (dependent upon road speed and accelerator pedal position).

If the accelerator pedal is pushed down to its full extent and then immediately released, unlike most 'automatic' vehicles, the transmission will not automatically select the highest suitable gear ratio. Instead, the transmission will maintain the current gear ratio, to enable engine braking. This function is especially useful when an overtaking manoeuvre is aborted, enabling the driver to retake the vehicle's previous road position and avoid colliding with the vehicle in front.

Parking

After bringing the vehicle to a stop, ALWAYS fully apply the handbrake and select 'P', before releasing the foot brake and switching off the engine.

AUTOMATICALLY SELECTED MODES

The transmission control system automatically selects different gear change modes, listed below, designed to suit a variety of driving conditions.

NOTE: *Automatically selected modes cannot be manually selected by the driver and will not operate if 'Sport' mode is selected.*

Hill ascent, trailer and high altitude mode

A suitable gear change pattern is selected to counter momentum loss, caused by the more frequent gear changing which can occur when climbing hills, or when towing a trailer or caravan. This gear change pattern is also selected at high altitudes to combat low engine torque.

Cruise control mode

When cruise control is activated, a suitable gear change pattern is selected which is less sensitive to throttle changes. This reduces the amount and frequency of gear changes, providing a smoother ride.

High coolant temperature mode

In high ambient temperatures during extreme load conditions, it is possible for the engine and the gearbox to overheat. At a certain temperature the transmission will select a gear change pattern designed to aid the cooling process, whilst enabling the gearbox to continue performing normally in high temperatures.

Hill Descent Control

HILL DESCENT CONTROL

Hill Descent Control (HDC) is of particular value when driving off road, and operates in conjunction with the anti-lock braking system to provide greater control in off-road situations, when descending severe gradients.

Selecting HDC

HDC can be selected with the vehicle in any gear, but will only operate once 1st or reverse gears ('1' or 'R' for automatic transmission) are engaged.

NOTE: Reverse gear should only be selected when the vehicle is stationary.

With HDC selected, if 1st or reverse gear have been engaged, the HDC information light (GREEN) in the instrument panel will illuminate continuously (if 1st or reverse gear have not been selected, the information light will flash).

Manual gearbox models:

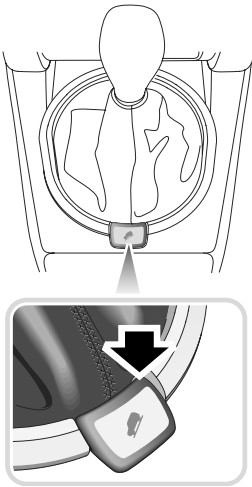

H5218

To select, press the HDC button, situated to the rear of the gear selector lever.

Automatic gearbox models:

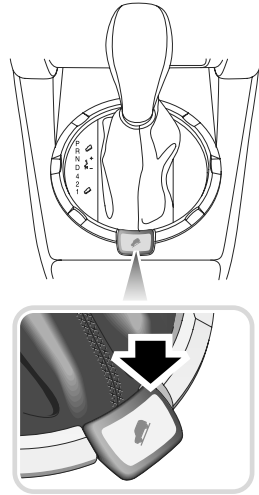

H5172

To select, press the HDC button, situated to the rear of the gear selector lever.

Deselecting HDC

Manual gearbox models:
Press the HDC button.

Automatic gearbox models:
Press the HDC button.

Hill Descent Control

Hill descent control in action

During a descent, if engine braking is insufficient to control the vehicle speed, HDC (if selected) automatically operates the brakes to slow the vehicle and maintain a speed relative to the accelerator pedal position.

When driving off-road, HDC can be permanently selected, to ensure that control is maintained whenever 1st or reverse gears ('1' or 'R' for automatic transmission) are engaged. ABS and traction control are still fully operational and will assist if the need arises.

NOTE: *HDC can be left selected while off-road driving, the system will only operate when needed and gear changes can be carried out in the normal way.*

If the brake pedal is depressed when HDC is active, HDC is overridden and the brakes will perform as normal (a pulsation might be felt through the brake pedal). If the brake pedal is then released, HDC, if necessary, will recommence operating.

On models with a manual gearbox, if the clutch is depressed for longer than 3 seconds while HDC is operating, the HDC information light will flash. If, after 60 seconds the clutch is still depressed, the information light extinguishes and the HDC 'failure' warning light flashes as the system gradually fades out.

WARNING

On models with a manual gearbox, Do not depress the clutch pedal when descending a steep slope - control of the vehicle will be compromised and HDC will no longer function.

In extreme circumstances, the HDC system may cause brake temperatures to exceed their pre-set limits. If this occurs, the information warning light will extinguish and the HDC 'failure' warning light (AMBER) will start to flash. You should stop the vehicle and disengage HDC. If HDC remains operating and the brake temperature continues to rise the HDC system will gradually fade out and the 'failure' warning light will continue to flash until the brakes have cooled.

HDC fade-out

HDC fade-out gradually decreases the HDC brake intervention with the effect that the rate of hill descent will increase. If this occurs either one of the two HDC warning lights will flash for the period that HDC takes to fade. HDC will be disabled completely once the descent is complete.

If required (e.g. the angle of the descent levels out significantly), fade-out may be achieved deliberately by deselecting HDC while the system is operating or by changing out of the appropriate operating gear, in which case the green information light will flash. Fade-out will also occur if the clutch is depressed for longer than 60 seconds, in which case the amber failure light will flash.

If a fault with the HDC system is detected, or if the braking system reaches a pre-set temperature due to extreme conditions, HDC will automatically fade out (amber failure light flashes).

Hill Descent Control

HDC warning lights



HDC information light - GREEN:

The light illuminates briefly as a bulb check when the starter switch is turned to position 'II'. If HDC is selected when either of the operating gears is engaged (1st or reverse - position '1' or 'R' for automatic transmission), the light will illuminate continuously. When HDC is selected and a non-operating gear is engaged, the light will flash to inform the driver that HDC is selected, but not operating. The light will also flash to indicate that HDC is fading out.



HDC 'failure' light - AMBER:

The light illuminates briefly as a bulb check when the starter switch is turned to position 'II'. The light will start flashing if the brakes become in danger of overheating and continue flashing until the brakes have cooled sufficiently for HDC to operate again.

On manual models, the light will also flash if the clutch is depressed for longer than 60 seconds as the system fades out.

If the light illuminates at any other time, a fault in the system is indicated. If this occurs, deselect HDC and consult your Land Rover dealer.

Cruise Control

CRUISE CONTROL *

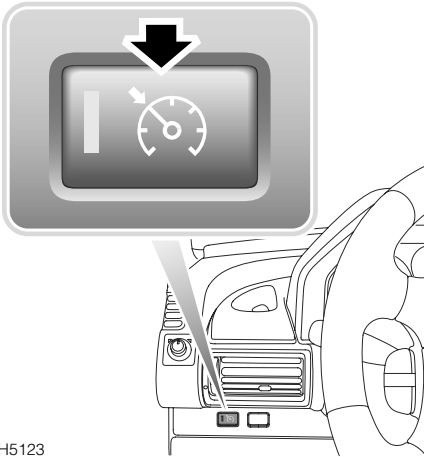

H5123

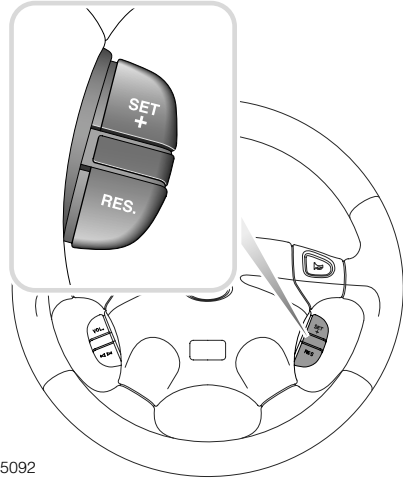

H5092

Cruise control enables the driver to maintain a constant road speed without using the accelerator pedal. This is particularly useful for motorway cruising or for any journey where a constant speed can be maintained for a lengthy period.

The cruise control system has three switches; a master switch on the left side of the instrument binnacle and two control switches marked 'SET +' and 'RES' mounted on the steering wheel.

IMPORTANT

Always observe the following precautions:

- DO NOT use cruise control when using reverse gear ('R' for automatic transmission).
- DO NOT use cruise control on winding or slippery road surfaces, or in traffic conditions where a constant speed cannot easily be maintained.
- Use of 'sport' mode on automatic gearbox vehicles is not recommended when cruise control is selected.
- ALWAYS switch off the master switch when you no longer intend to use cruise control.

Cruise Control

WARNING

On petrol engine vehicles, DO NOT rest your foot under the accelerator pedal while cruise control is engaged - your foot could be trapped.

To operate:

1. Press the master switch (the switch indicator light and the warning light in the instrument panel illuminate whenever the switch is pressed to the 'on' position).
2. Accelerate until the desired cruising speed is reached. This must be above the system's operational minimum speed of 45 km/h.
3. Press the 'SET +' switch to set the vehicle speed in the system's memory. Cruise control will now maintain that road speed without the need for operation of the accelerator pedal.

With cruise control operating, speed can be increased, by normal use of the accelerator, when overtaking for example. When the accelerator is released, road speed will return to the selected cruising speed. On diesel engine vehicles, cruise control will be disengaged if the accelerator is used for longer than 30 seconds - press 'RES' to re-engage.

NOTE: *If the 30 second period is exceeded, cruise control will automatically disengage. Press the 'RES' switch to re-engage.*

To reduce the cruising speed:

Press the 'RES' switch to slow the vehicle, until the required speed has been reached. Then press the 'SET +' switch to establish the new cruising speed (remember that cruise control will not operate at speeds below 45 km/h).

To increase the set cruising speed:

Press and hold the 'SET +' switch - the vehicle will accelerate automatically. Release the switch as soon as the desired speed has been reached.

Alternatively, the set speed can be increased incrementally by 'tapping' the 'SET +' switch. Each press of the switch will increase the speed by approximately 1.5 km/h.

Disengaging cruise control

On manual gearbox vehicles, the cruise control will automatically disengage if the brake or clutch pedals are pressed. On automatic gearbox vehicles, cruise control will disengage when the gear selector is moved into neutral, or when the brake pedal is pressed. Cruise control can also be disengaged by pressing the 'RES' switch.

To re-engage cruise control at the previously set speed, press the 'RES' switch.

NOTE: *The speed held in the cruise control memory will be cancelled when either the cruise control master switch or the starter switch is turned off.*

Brakes

FOOT BRAKE

For your safety, the hydraulic braking system operates through dual circuits. However, in the event of a brake failure where only one circuit is operational, the vehicle should only be driven at slow speed to the nearest Land Rover dealer. In these circumstances, exercise EXTREME CAUTION and be aware that much greater pedal effort and longer stopping distances will be required.

Servo assistance

The braking system is servo assisted, but ONLY when the engine is running. Without this assistance greater braking effort is necessary to safely control the vehicle, resulting in longer stopping distances. Always observe the following precautions:

- NEVER allow the vehicle to freewheel with the engine turned off.
- ALWAYS take particular care when being towed with the engine turned off.
- If the engine should stop for any reason while the vehicle is in motion, bring the vehicle to a halt as quickly as traffic conditions safely allow, and DO NOT pump the brake pedal as the braking system may lose any remaining assistance available.

Brake pads

Brake pads and linings require a period of bedding in. For the first 300 km, you should avoid situations where heavy braking is required.

Remember that regular servicing is vital to ensure that the brake components are examined for wear at the correct intervals and changed whenever necessary to ensure long term safety and optimum performance.

WARNING

DO NOT rest your foot on the brake pedal while travelling as this may overheat the brakes, reduce their efficiency and cause excessive wear.

NEVER move a vehicle without the engine running because braking assistance will not be available. The pedal brakes will still function, but more pressure will be required to operate them.

If the brake warning light should illuminate while the vehicle is in motion, bring the vehicle to a halt as quickly as traffic conditions and safety permit and seek qualified assistance before continuing. DO NOT pump the brake pedal - the braking system may lose any remaining servo assistance available.

Brake warning light



If the warning light on the instrument panel illuminates while driving, and the handbrake is fully released, a fault with the braking system is indicated. Check the brake fluid level; if the light continues to illuminate, seek qualified assistance before continuing.

Wet conditions

Driving through water or even very heavy rain may adversely affect braking efficiency. Always dry the braking surfaces by intermittent light application of the brakes, first ensuring that you are at a safe distance from other road users.

Brakes

HANDBRAKE

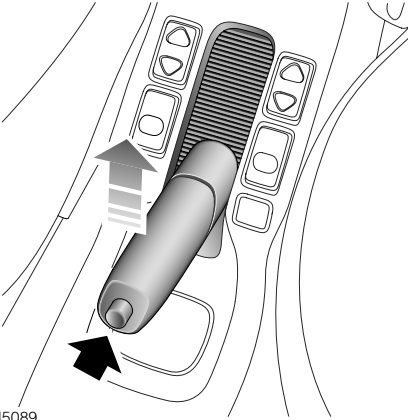

H5089

The handbrake operates on the rear wheels only and should not require adjustment.

To engage the handbrake, pull the lever up fully.

To release, pull the lever up slightly, depress the button (arrowed in illustration) and lower the lever.

When parking on a slope, do not rely on the handbrake alone to hold the vehicle. On manual gearbox models, the vehicle should be parked in a low forward gear when facing uphill and in reverse gear when facing downhill.

On automatic gearbox models, ensure the parking pawl of the gearbox has fully engaged by carefully releasing the foot brake and allowing the vehicle to 'rock' into 'P' (park).

WARNING

Always apply the handbrake fully whenever the vehicle is parked.

DO NOT drive with the handbrake applied; this could result in loss of vehicle control, damage the rear brakes and will also prevent the anti-lock braking system from functioning correctly.

DO NOT rely on the handbrake to operate effectively if the vehicle has been subjected to immersion in mud and water (see 'Off-road driving' section).

Brakes

ANTI-LOCK BRAKES

WARNING

ABS cannot overcome the physical limitations of stopping the vehicle in too short a distance, cornering at too high a speed, or the danger of aquaplaning, i.e. where a layer of water prevents adequate contact between the tyres and the road surface.

The fact that a vehicle is fitted with ABS must never tempt the driver into taking risks that could affect his/her safety or that of other road users. In all cases, it remains the driver's responsibility to drive within normal safety margins, having due consideration for prevailing weather and traffic conditions.

The ABS is designed to operate only with the tyres specified in 'Technical Data' (see 'WHEELS & TYRES', page 240) and genuine Land Rover parts. The manufacturers cannot accept any responsibility for inefficient operation of the system caused by modifications to the vehicle, or the fitting of non-approved components. Always consult your Land Rover Dealer/Authorised Retailer for advice.

The driver should always take account of the surface to be travelled over and the fact that brake pedal reactions will be different to those experienced on a non-ABS vehicle.

The purpose of the anti-lock braking system (ABS) is to allow efficient braking without wheel locking - thereby allowing the driver to retain steering control of the vehicle.

Under normal braking conditions, (where sufficient road surface friction exists to reliably bring the vehicle to a halt without the wheels locking), ABS will not be activated. However, should the braking force exceed the available adhesion between the tyres and the road surface causing one or more wheels to lock, then ABS will automatically come into operation. This will be recognisable by a rapid pulsation felt through the brake pedal.

NOTE: Immediately after the engine is started, a short, low pitched 'buzz' may be heard; this is the ABS system priming and is no cause for concern.

Anti-lock braking in action

In normal road use, during an emergency situation full braking effort should always be applied even when the road surface is slippery. The anti-lock braking system constantly monitors the speed of each wheel and varies braking pressure to each, according to the amount of traction available, thereby ensuring that the wheels do not lock.

No matter how hard you brake, you should be able to continue steering the vehicle as normal.

- DO NOT pump the brake pedal at any time; this will interrupt operation of the system and may increase braking distance.
- DO NOT place non-approved floor mats or any other obstruction under the brake pedal. This restricts pedal travel and, therefore, impairs braking efficiency.

Brakes

NOTE: On soft surfaces such as powdery snow, sand or gravel, braking distances may be greater than those achievable on a vehicle without anti-lock braking. This is because the action of locked wheels on loose surfaces, is to build up a wedge of material in front of the wheels, which assists in bringing the vehicle to a halt. However, even in these circumstances, the anti-lock braking system will provide better stability and steering control.

Warning light



The anti-lock braking system incorporates a monitoring system, which checks that all the electrical components are in working order, as soon as the starter switch is turned to position 'II' and also at frequent intervals during your journey.

The warning light on the instrument panel is an important part of this system. The warning light should illuminate for approximately one second when the starter switch is turned to position 'II' and then extinguish. The light may blink during this time.

If the light remains on or subsequently illuminates while driving, a fault has been detected by the self monitoring system and full ABS control may not be available - consult your dealer at the earliest opportunity.

The normal braking system remains fully operational and is not affected by partial or full loss of the ABS. However, braking distances may increase.

Off-road driving

While anti-lock braking is designed to operate equally effectively in 'off-road' driving conditions, on certain surfaces total reliance on the system may be unwise - remember, in normal circumstances, anti-lock braking operates only AFTER the driver has already lost control. It cannot reliably compensate for driver error or inexperience on difficult off-road surfaces.

Note the following:

- If the vehicle is stopped on a very steep slope where little traction is available, it may slide with the wheels locked because there is no wheel rotation to signal movement to the ABS. To counteract this, briefly release the brakes to permit some wheel movement, then re-apply the brakes to allow ABS to gain control.
- Before driving off-road, read and thoroughly understand the '*Off-road driving*' section of this handbook.
(See '*BEFORE YOU DRIVE*', page 155).

Traction Control

ELECTRONIC TRACTION CONTROL

The purpose of electronic traction control is to aid traction when one wheel spins while the other still has good grip (if one side of the vehicle is on ice and the other is on tarmac, for example). The system works by applying the brake to a spinning wheel in order to transfer torque to the other side of the axle.

NOTE: Traction control only operates below approximately 50 km/h.

Warning light



The instrument panel warning light will illuminate whenever the system is active (for a minimum of 2 seconds) and also illuminates as a bulb check (for approximately 4 seconds) when the starter switch is turned to position 'II'.

If the warning light illuminates continuously while traction control is NOT operating, a fault with the system is indicated; seek qualified assistance.

The light also has an overheat function: if traction control is required, but the brakes are too hot, the light will flash for the period when traction control is required and traction has been lost.

Parking Aid System

USING THE PARKING AID SYSTEM

WARNING

The parking aid is not infallible; it is for guidance only! The sensors may not be able to detect certain types of obstruction (narrow posts or small narrow objects, small objects close to the ground and some objects with dark, non-reflective surfaces, for example).



H5048

The parking system assists the driver when manoeuvring the vehicle into a parking space, or anywhere that there are obstacles that need to be avoided, warning the driver accordingly.

The vehicle is fitted with four ultrasonic sensors on its rear bumper.

The range of the two outer sensors is approximately 0.6 m; the two inner sensors have a range of approximately 2 m.

WARNING

Keep the sensors free from dirt, ice and snow. If deposits build up on the surface of the sensors, their performance may be impaired. When washing the vehicle, avoid aiming high pressure jets directly at the sensors from close range.

Activating Parking Aid

The Parking Aid feature is available whenever the starter switch is turned on. When reverse gear is selected, the indicator light in the switch illuminates and a short tone sounds after one second.

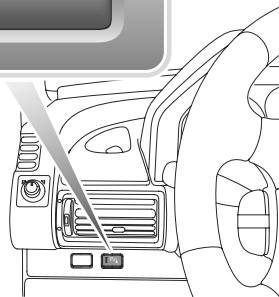
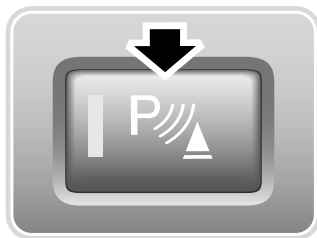

H5046

If a long, high pitched tone sounds and the switch indicator light flashes, a fault in the system has been detected - contact your Dealer/Authorised Repairer for assistance.

Parking Aid System

Parking Aid in operation

The distance from an obstruction is identified by an intermittent tone sounding. As the vehicle moves closer to an obstruction, the frequency of the tone increases proportionally.

When the distance between the sensor and the obstruction is less than approximately 0,3 m, the tone becomes continuous.

Manual de-activation

When in reverse gear ('R'), the Parking Aid feature can be manually de-activated by pressing the switch in the fascia panel. A second press of the switch re-activates the system. The indicator light in the switch illuminates and a short tone sounds as confirmation of re-activation.

NOTE: *If the Parking aid system has been manually de-activated, it will remain in this mode until either the switch is pressed again whilst in reverse gear ('R') or the engine is restarted. If the vehicle is in any other gear, the switch has no effect.*

Targa Roof

TARGA ROOF

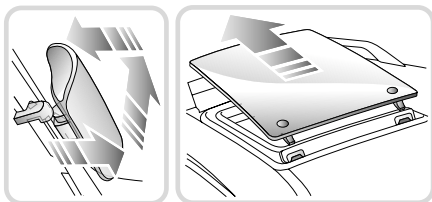
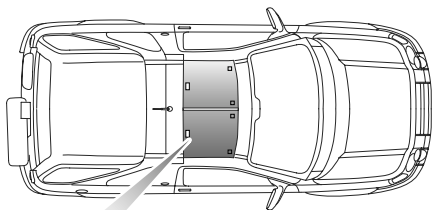

H5211

The targa roof is made up of twin glass or composite panels set into the roof. Either or both of which can be tilted open or removed.

Tilting a panel (see left inset)

1. Pull the handle forward to unlock.
2. Push the handle up.
3. Push the handle to the rear until it 'clicks' into the lock position.

To close the panel, reverse the above procedure.

Removing a panel

WARNING

DO NOT attempt to remove the targa roof panels when the vehicle is moving!

Half tilt the panel (as in 1 and 2 above), then press the red catch to detach the handle linkage. From outside the vehicle, raise the rear of the panel until the two front hinges disengage and lift the panel off.

NOTE: Handle glass with care, avoid damage to the surfaces, especially along the edges.

WARNING

DO NOT allow passengers to extend any part of their bodies through roof apertures while the vehicle is moving - injury from flying debris, branches of trees or other obstructions could occur.

Storing the panels

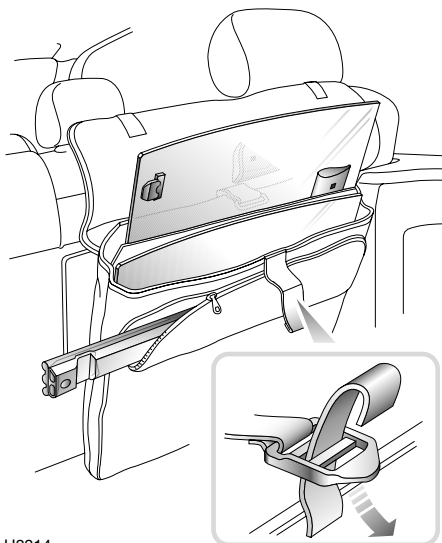

H3314

After removal, always protect the panels by placing them sideways in the stowage case attached to the rear seats in the luggage compartment as shown.

WARNING

DO NOT drive with the roof panels loose in the vehicle, they could become dangerous projectiles in the event of an accident or emergency manoeuvre.

Targa Roof

Refitting a panel

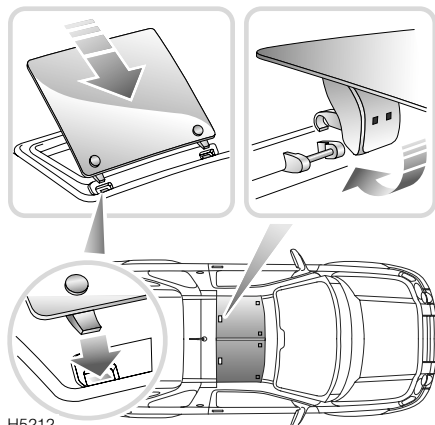

Before refitting, note that the panels are not interchangeable because the curvature at each side of the roof is more pronounced than in the centre. To ensure accurate refitting, the one rounded corner of the panel should be positioned at the front OUTSIDE corner.

1. Locate the hinges over the top of and through the slots in the wind deflector into their appropriate slots at the front of the roof.
2. Lower the roof and, ensuring that the handle linkage is the correct way up, push the handle rearwards as if to lock.
3. The handle should now be engaged - ensure that the red button is fully retracted, then attempt to open (tilt) the roof to check.

NOTE: ALWAYS close and secure the roof when the vehicle is to be left unattended.

Removing the 'T-bar'

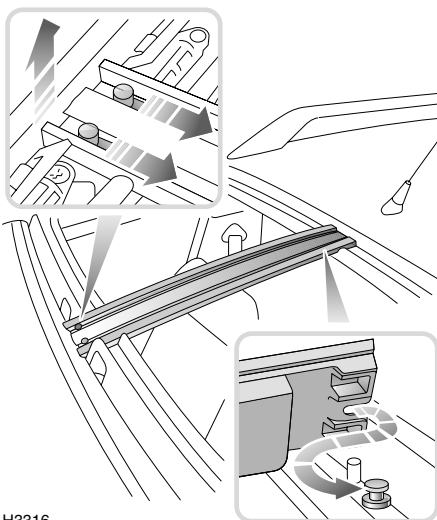

With both panels removed, the 'T-bar' can also be removed:

- Press the RED catches rearwards (as arrowed), then pull the bar upwards and then forwards to remove.

NOTE: The 'T-bar' can be stowed in the pocket provided in the stowage bag in the luggage compartment (see 'Storing the panels', page 125)

When replacing, ensure that the 'T-bar' is secured at the rear, before pushing downwards to engage the front (RED) locking catches.

Softback

FOLDING AND UNFOLDING THE SOFTBACK*

Folding

WARNING

Before folding the softback, it is recommended that the radio aerial is either tilted towards the vertical, or removed to avoid accidental injury.

NOTE: If roof bars are fitted, they **do not** need to be removed to fold or unfold the softback.

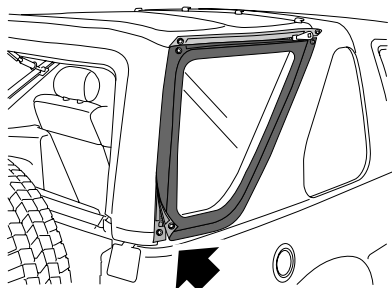

H4300A

1. With the taildoor closed, undo Velcro, stud and zip fasteners to release the side screens.

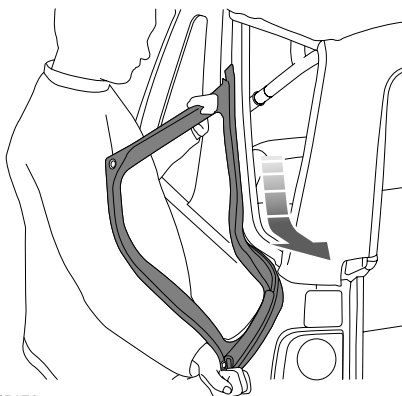

H5176

2. Slide the side screen down and out of the retaining channel.

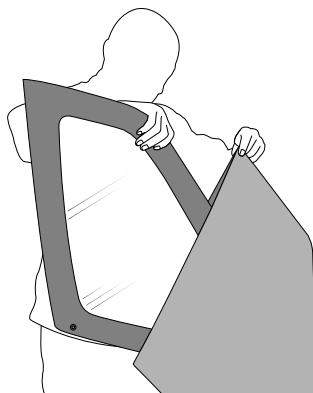

H3386

3. Open the taildoor and store the side screens in the stowage bag when not in use - ensure the screens are dry before stowing.

Softback

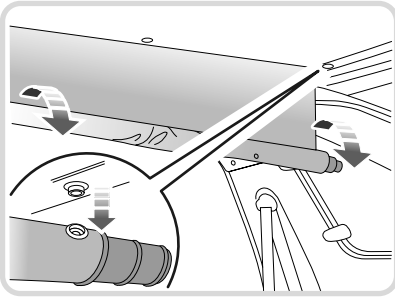
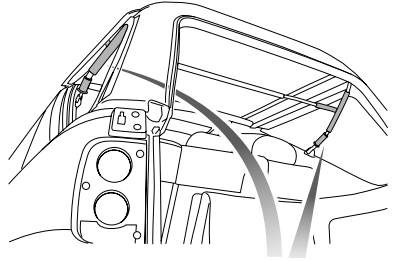
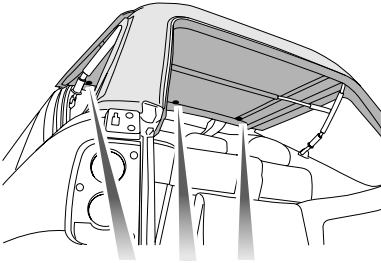

H5177

4. From inside the vehicle, unfasten the three press studs retaining the tonneau cover and allow the cover to unroll.

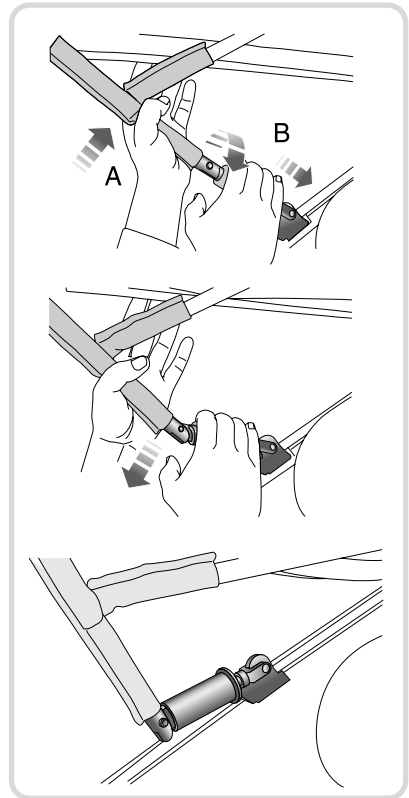

H5178

5. From inside the vehicle:
Push up elbow stay (A).
Push down and twist elbow stay locking collar (B) and allow the stays to hinge downwards. (Left hand side shown).

Softback

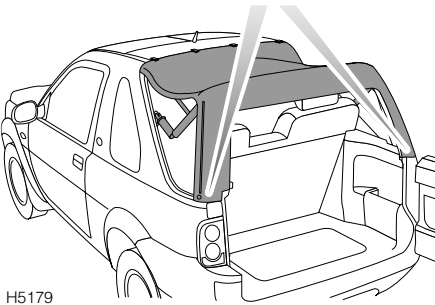
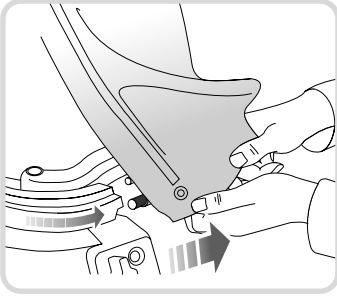

H5179

6. From outside the vehicle, slide both corner post beadings (fabric) out of their retaining channels. (Left hand side shown).

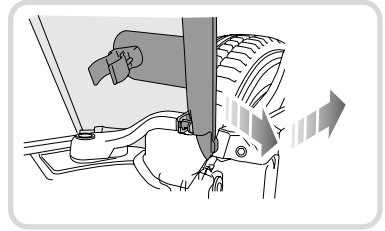
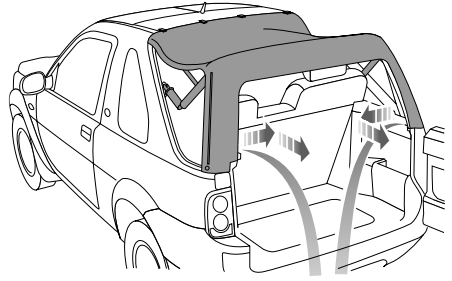

H5180

7. Pull the posts towards the centre of the vehicle and pull rearwards to release.

Softback

8. While pushing upwards on the centre roof bow, fold the softback forwards and above the back edge of the fixed roof.

NOTE: If roof bars are fitted, the softback **will** slide along the underside of the bars, although with greater resistance.

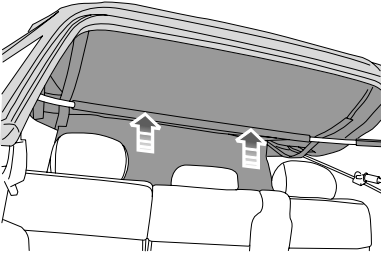

H4304

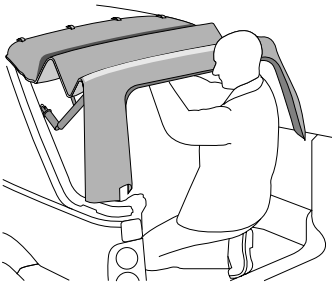

H4305A

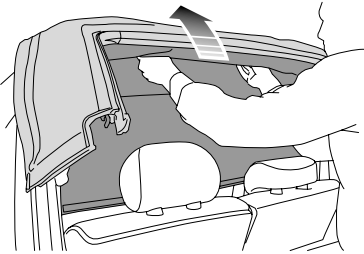

H4306

Softback

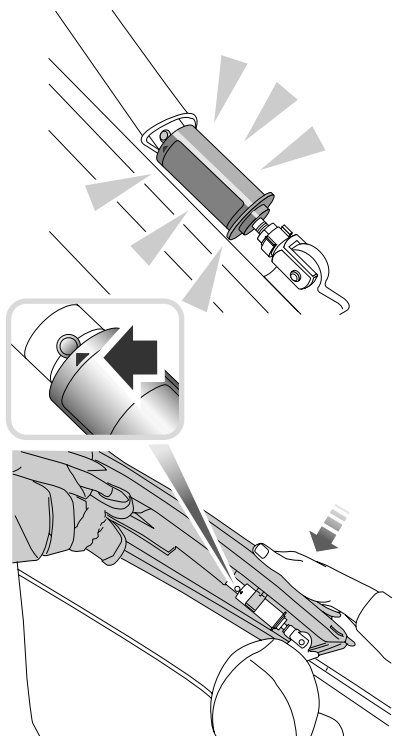

H4307

9. Straighten the elbow stay until the locking collar 'snaps' up, and the location arrow moulded into the collar is rotated to align with the centre of the rivet on the elbow stay (see inset). Attach corner post clips to the locking collar. (Right hand side shown).

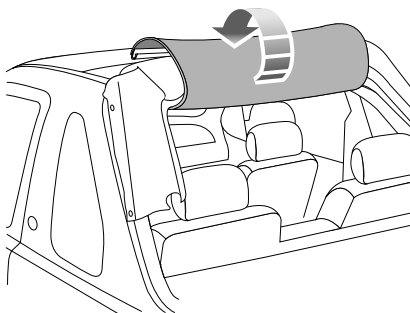

H3394

10. Wrap the tonneau cover over the softback assembly.

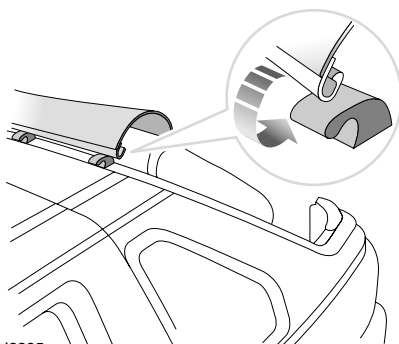

H3395

11. Hook the leading edge of the tonneau cover over the four hooks located on the top of the back edge of the fixed roof.

Softback

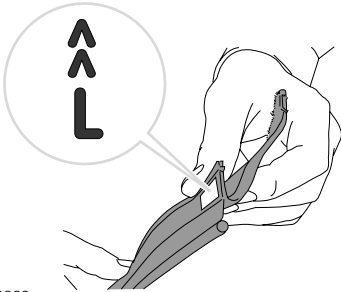

H4339

12. Retrieve side covers from taildoor pocket and fold out beading. Label shows orientation. ('L' = Left hand, 'R' = Right hand).

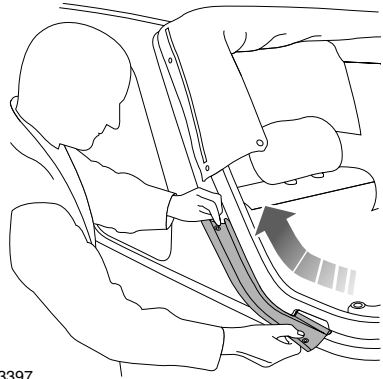

H3397

14. Slide the side cover up the retaining channel.

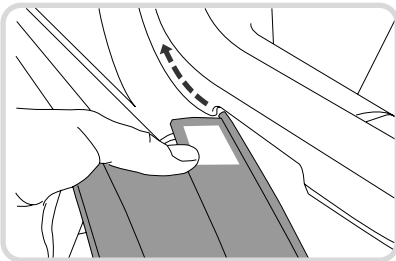
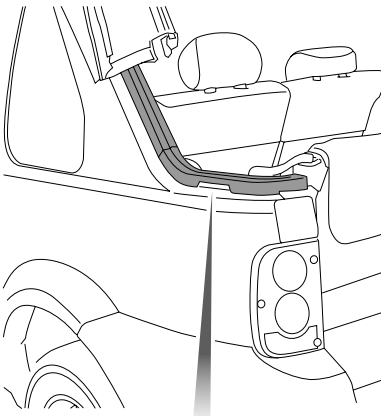

H5181

13. Feed appropriate side cover ('L' or 'R') into the retaining channel in the direction of the chevrons. (Left hand side shown).

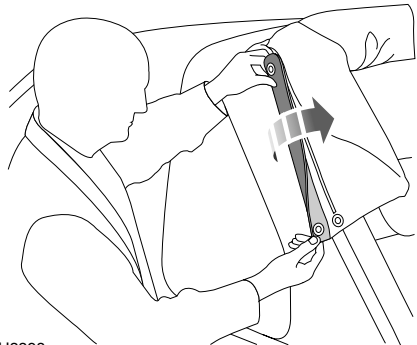

H3398

15. Attach stud and Velcro fasteners.

NOTE: The roof aerial can now be repositioned.

Softback

Unfolding

WARNING

Before unfolding the softback, it is recommended that the radio aerial is either tilted towards the vertical, or removed, to avoid accidental injury.

NOTE: If roof bars are fitted, they **do not** need to be removed to fold or unfold the softback.

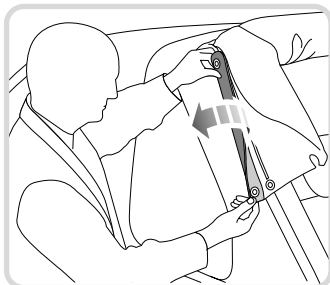
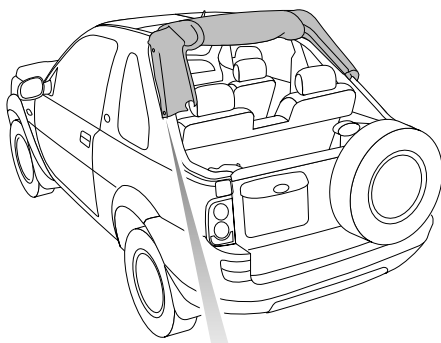

H5182

1. Unfasten the side cover Velcro and stud fasteners.

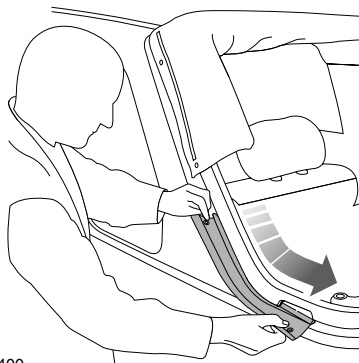

H3400

2. Slide the cover out of the retaining channel.

NOTE: Store the side covers in the taildoor pocket in the loadspace.

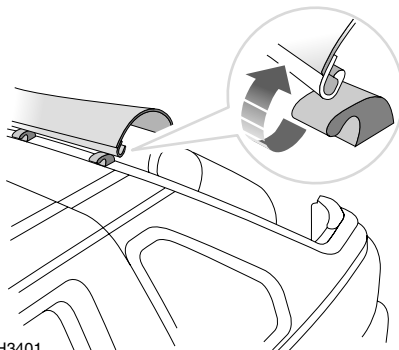

H3401

3. From inside the vehicle and with the taildoor open, unhook the tonneau cover from the four hooks located on the top of the back edge of the fixed roof.

Softback

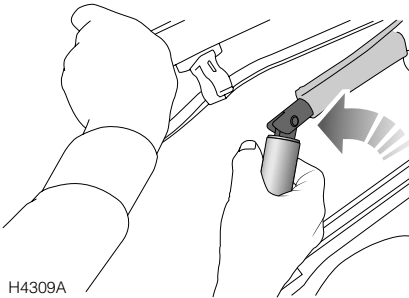
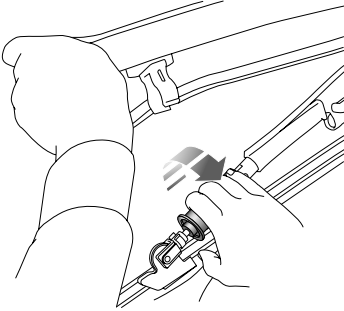
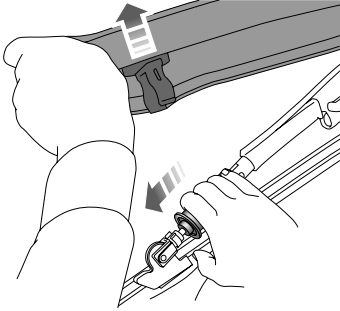

H4309A

4. From inside the vehicle, detach the corner post clips. Pull and twist to release the elbow stay locking collar. When the locking collar has unlocked, lift rearwards to initiate the folding sequence. (Left hand side shown).

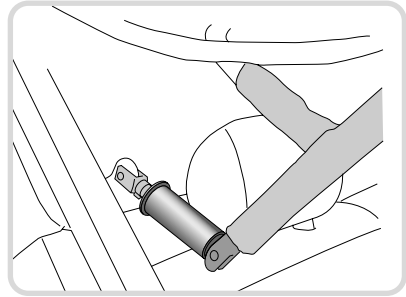
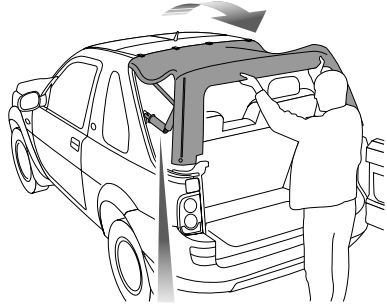

H5183

5. Unfold the softback rearwards. Check that the elbow stays have remained unlocked, as indicated above.

Softback

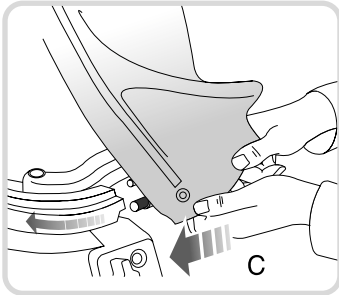
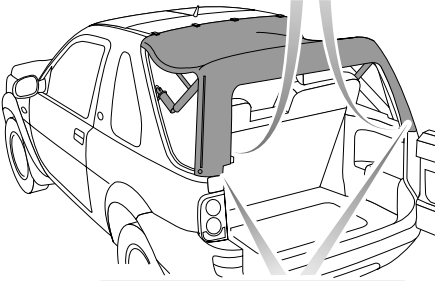
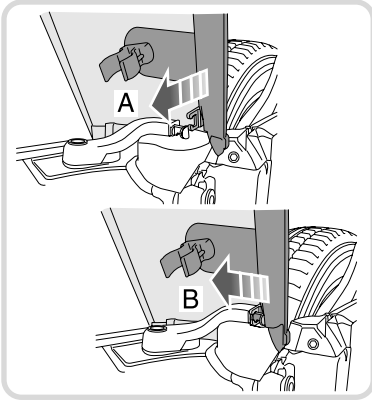

H5184

- 6.** A - From inside the vehicle, pull the corner posts forward into the catch position.
B - Push the corner posts away from the centre of the vehicle to lock.
C - Feed the corner post beading into the retaining channel. (Left hand side shown).

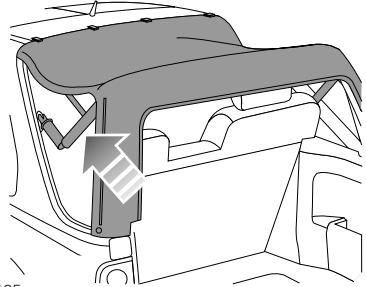

H5185

- 7.** Push up (where arrowed) to straighten the elbow stay.

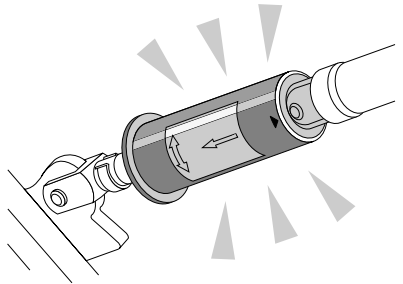

H3406A

- 8.** Ensure elbow stay locking collar 'snaps' up, and the location arrow moulded into the collar aligns with the rivet on the elbow stay.

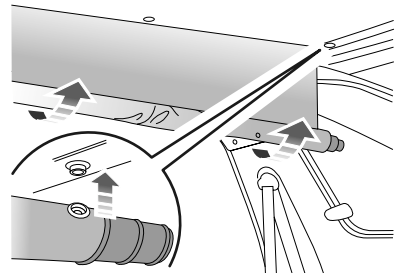

H4312

- 9.** Roll up tonneau cover and secure with the three press studs.

Softback

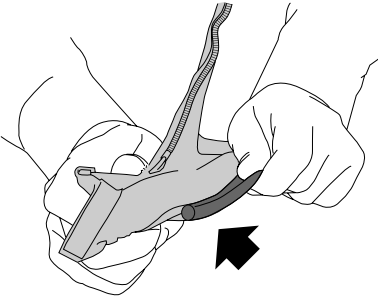

H4338

- 10.** Remove the side screens from the storage bag and fold out the beading.

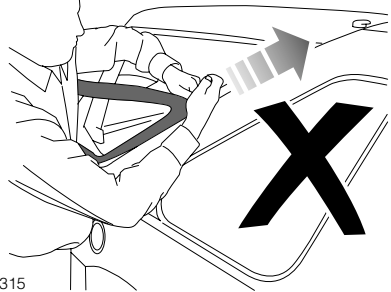

H4315

- 12.** Do not pull the side screen from the top, as this may damage either the side screen or vehicle, or both.

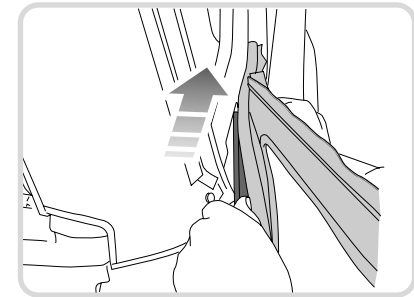
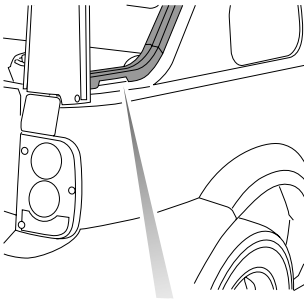

H5186

- 11.** With the taildoor closed, locate the side screen beading into the retaining channel, as indicated. (Right hand side shown).

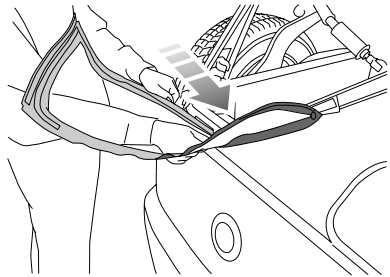

H4314

- 13.** Slide the side screen into the retaining channel, continuing to push from the bottom until the two halves of the lower press stud align.

Softback

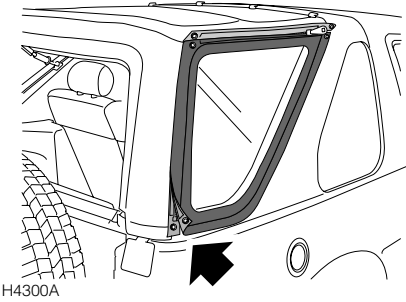

14. Attach zip fastener and zip-up, secure press studs and Velcro.

NOTE: *The roof aerial can now be repositioned.*

Hardback

REMOVING AND FITTING THE HARDBACK*

Removal

Roof bars* MUST be removed prior to removing the hardback, (See 'REMOVING AND FITTING THE ROOF BARS*', page 142).

NOTE: To avoid damaging the vehicle, hardback removal/refitting is best carried out by two people.

WARNING

The hardback is a heavy item. Removing and fitting should be carried out by two people.

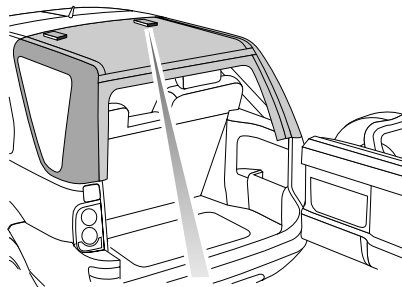

H5187

1. Press the button on the catch, then push the catch forwards and allow to drop.

Hardback

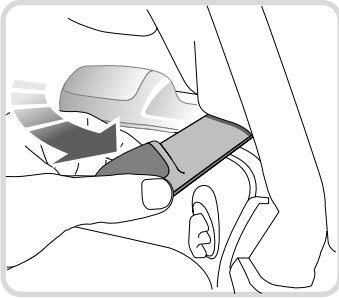
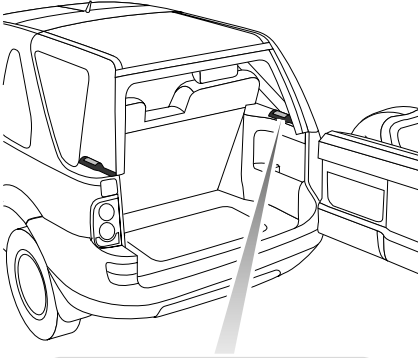

H5188

2. Pivot the rear locking levers 90° rearwards.

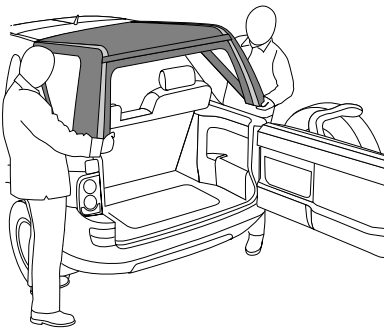

H5189

3. With assistance, lift the hardback (rear first) from the vehicle.

Hardback

Fitting

NOTE: The roof bars * *MUST* be removed, prior to fitting the hardback to the vehicle (see 'REMOVING AND FITTING THE ROOF BARS*', page 142).

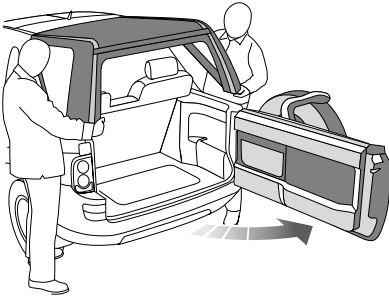

H5190

1. Open taildoor, then with assistance, angle the hardback as shown and position on the vehicle.

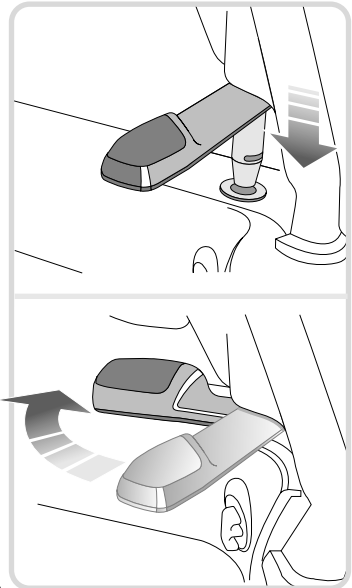
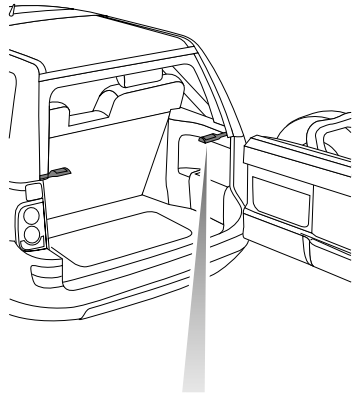

H5191

2. Locate the rear locking pins and pivot both locking levers 90° forwards.

Hardback

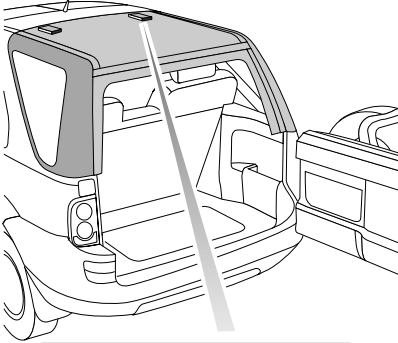

3. Push the front of the header catch upwards, slide it rearwards and push the rear of the catch upwards until it 'snaps' into position.

WARNING

Do not drive the vehicle if the header catches are not secure.

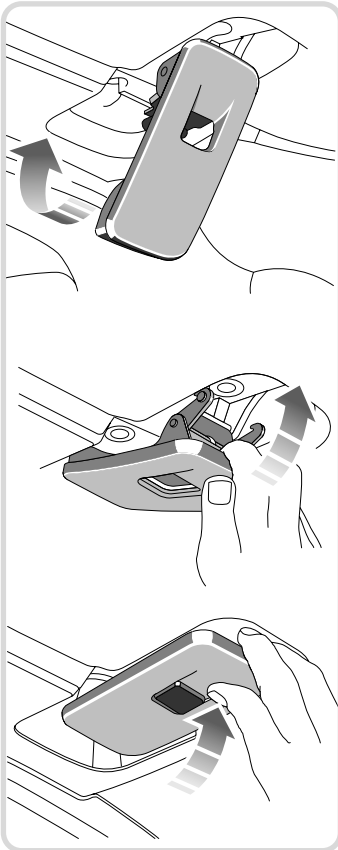

H5192

Roof Bars

REMOVING AND FITTING THE ROOF BARS*

Removal

WARNING

DO NOT remove or adjust any bolt other than those highlighted in the following illustrations.

NOTE: To avoid causing accidental damage to the vehicle, removal and refitting of roof bars is best carried out by two people.

The following procedure must be repeated for the right hand side of the roof bars.

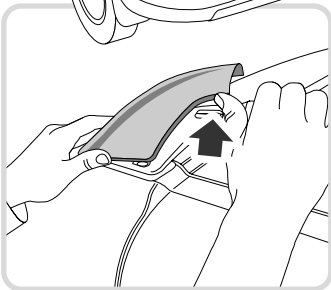
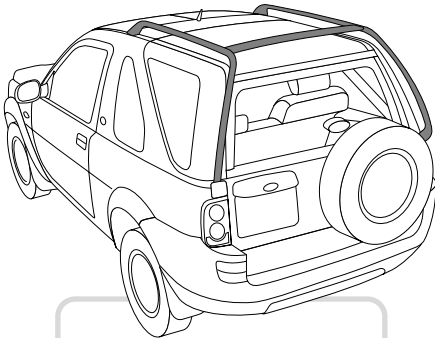

H5195

1. Remove front finisher - push upwards where arrowed.

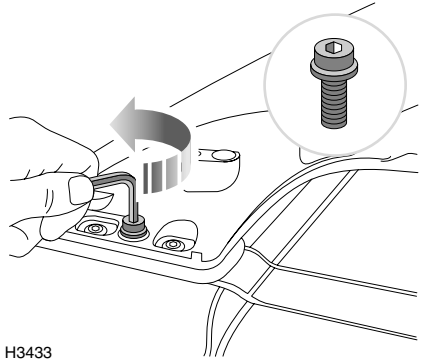

H3433

2. Unscrew the front fixing bolt using a Torx key.

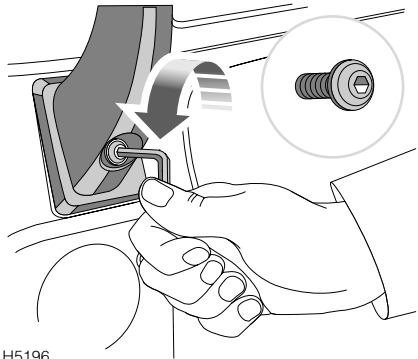

H5196

3. Unscrew the rear fixing bolt.

Roof Bars

Fitting

NOTE: The following procedure must be repeated for the right hand side of the roof bars.

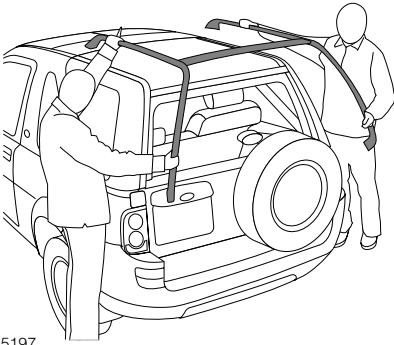

H5197

4. With assistance, lift the roof bars up and rearwards off the vehicle.

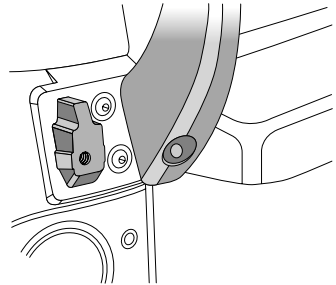
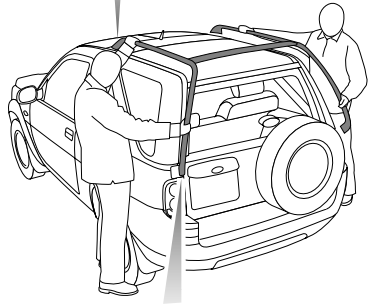
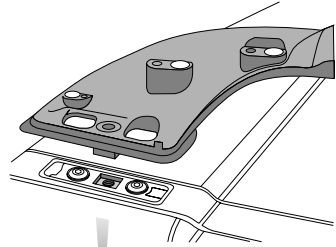

H5198

1. With assistance, carefully position the roof bars onto the vehicle.

Roof Bars

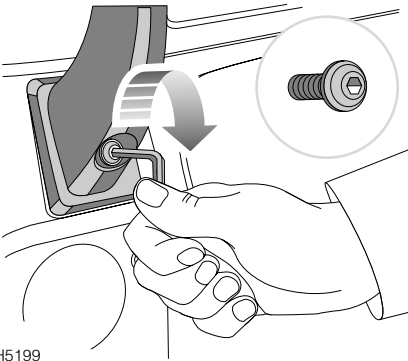

H5199

2. Screw the correct bolt into the rear fixing and fully tighten using a Torx key.

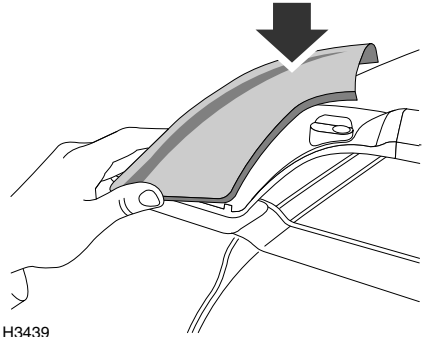

H3439

4. Align the pegs on the underside of the front finisher with the holes at the front of the roof bar and push down to fit.

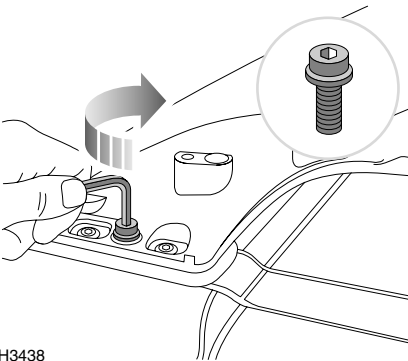

H3438

3. Screw the correct bolt into the front fixing and fully tighten. Ensure that the roof bars are rigid.

Taildoor

OPENING AND CLOSING

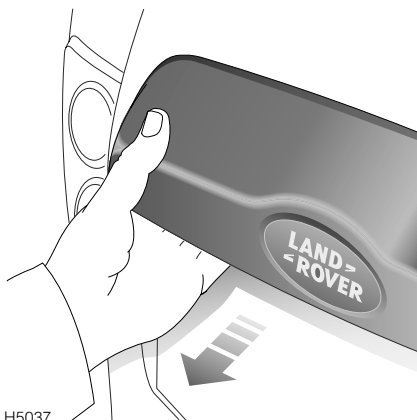

Opening the taildoor

When the release catch is pulled (as shown in illustration), the taildoor lock is released in two phases:

1. the taildoor glass drops clear of its retaining channel.
2. the electronic door latch is released and the door can be opened.

Initially, the door opens approximately half way until resistance is felt; this prevents the door swinging fully open and possibly hitting an obstruction, yet still enables access in a situation where there is not enough room to open the door fully. Push, against resistance, to open the door fully.

NOTE: The taildoor latch will not operate if the glass is frozen to the door seals, as the glass needs to drop slightly before the door can be opened. Defrost the glass with warm water first.

WARNING

You are advised NOT to carry loads which require driving with the taildoor or taildoor window open - poisonous fumes will be drawn into the vehicle! If driving the vehicle in this condition is unavoidable, switch the heater to face level vents with all vents open, close the sunroof and windows and turn the air blower to position 4.

Closing

WARNING

When closing the taildoor, push on the handle - NOT on the taildoor glass.

Load carrying

Long loads should be carried on the roof rack. If it is necessary to carry a load that protrudes through the taildoor window aperture, the weight of the load must NOT rest on the glass. Damage to the glass or window mechanism may occur. (See also 'Accommodating long loads', page 38).

Load Carrying

LOADSPACE SIDE POCKETS

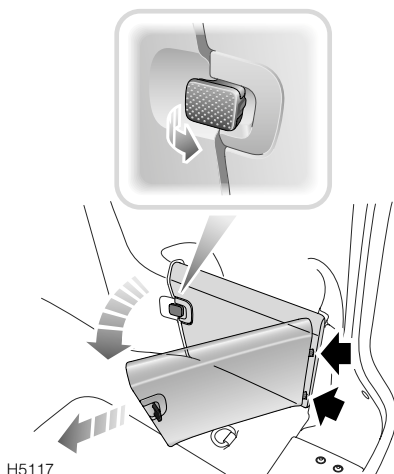

3-door models: The side-pocket panels* in the loadspace (illustrated above) can be removed to accommodate wider loads, by pulling the release catch towards the rear of the vehicle (see inset).

LUGGAGE ANCHOR POINTS

Four fixing points are provided in the rear loadspace floor, to assist in safely securing large items of luggage. Land Rover provide a range of approved luggage retention accessories.

WARNING

DO NOT carry unsecured equipment, tools or luggage, which could move and cause personal injury in the event of an accident or emergency manoeuvre either on or off- road.

STOWAGE BOX

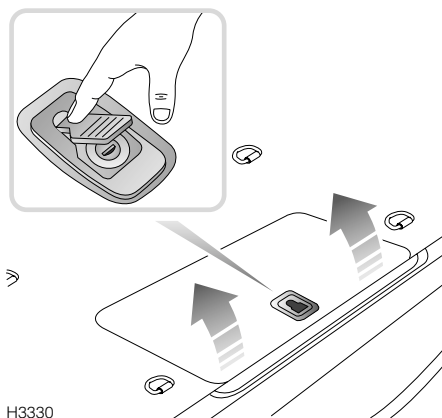

The stowage box, set into the loadspace floor, can be used to secure small or valuable items. On some models the box has a lockable lid, on others the lid is secured by turnbuckle fixings..

To lock or unlock: Press the flap (see inset) to access the lock. Insert the starter key and turn through 90° clockwise or anticlockwise.

NOTE: The stowage box may become hot when driving - do not store items in the stowage box, that could be damaged by heat.

NOTE: Do not store damp items in the stowage box for prolonged periods - condensation may cause mould to form.

On some models the audio system is equipped with a subwoofer housed in the stowage box. In this case, the box should not be used for carrying other equipment, and care should be taken to avoid knocking the underside of the subwoofer or disturbing the speaker harness and connection.

Load Carrying

VEHICLE LOADING

When loading a vehicle to its maximum (gross vehicle weight), consideration must be given to the unladen vehicle weight and the distribution of the load, to ensure that axle loadings do not exceed the permitted maximum values.

It is your responsibility to limit the vehicle load in such a way that neither the maximum axle loads nor the gross vehicle weight are exceeded (see 'VEHICLE WEIGHTS', page 245).

ROOF RACK

A range of roof rack systems is available as Land Rover approved accessories. For further information about roof rack systems approved for use with your vehicle, and advice as to which system would best suit your vehicle, please consult your Land Rover Dealer/Authorised Repairer.

The total roof rack load must NEVER exceed that given in 'TOWING WEIGHTS', page 246.

WARNING

DO NOT allow people to sit on the roof rack, or stand in the rear of the vehicle (even if holding on to the roof rack) when the vehicle is being driven.

IMPORTANT

- It is recommended that Land Rover approved load carrying accessories are used wherever possible.
- Only carry loads on cross-rails - do not attach loads directly to the roof bars.
- Use webbing straps (preferably with a ratchet clamp) to secure loads to cross rails - do not use elastic or 'bungee' straps.
- All loads should be evenly distributed and secured within the periphery of the rack.
- Position the roof rack and load so that it does not impede the opening of a sunroof.
- Any roof load will reduce the stability of the vehicle, particularly when cornering and encountering crosswinds.
- If it is necessary to stow luggage on a roof rack while driving off-road, all loads MUST be removed before traversing side slopes.
- Driving off-road with a loaded roof rack is not recommended. If it is necessary to stow luggage on the roof rack while driving off-road, all loads must be removed before traversing side slopes.
- Check to ensure the roof rack and load are secure after 50 km of any journey.

Load Carrying

Fitting the cross rails

A pair of cross rails should be fitted to the roof bars before carrying roof loads.

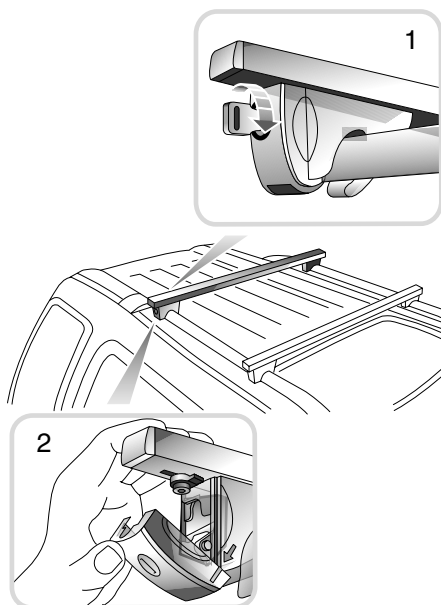

H3338

Unlock the clamps (1) (turn the key in the lock a quarter turn clockwise) at each end of the cross rail and pull the clamp covers (2) down.

Position the cross rails over the roof bars. The outside rubber edge of each clamp should be touching the roof bars. If this is not the case, loosen the bolt (3) with an Allen key and slide the clamp assembly along the cross rail until the correct fit is achieved, then retighten the bolt.

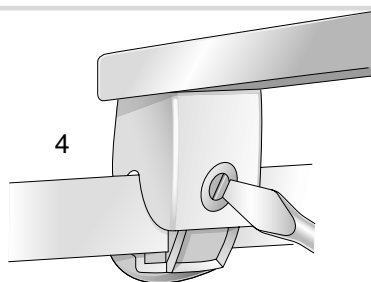
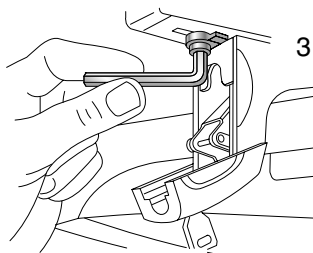

H3339

NOTE: On 3-door models, it is recommended that the cross rails are positioned towards the front of the roof bars to keep the weight towards the centre of the vehicle.

When the rail is in the desired position, push the clamp covers up. If no resistance is felt at the point where the line and arrow on the side of the clamp casing line up (see inset 2), tighten the grub screw (4) until there is resistance.

NOTE: Do not overtighten the screw as it will then be impossible to close the clamp cover.

Push the clamp cover fully upwards, check that the rail will not move and lock with the key (turn a quarter turn anti-clockwise).

Towing

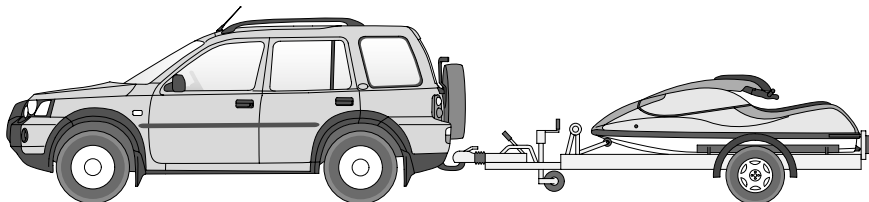

H5017

TOWING

It is the driver's responsibility to ensure that the towing vehicle and trailer/caravan are loaded and balanced so that the combination is stable when in motion. When preparing the vehicle for towing, pay careful attention to any instructions provided by the trailer/caravan manufacturer as well as the following information.

WARNING

To preserve the vehicle's handling and stability, it is recommended that you fit only towing accessories designed and approved by Land Rover.

DO NOT exceed the gross vehicle weight, maximum rear axle load, maximum trailer weight and tow hitch load (nose weight).

See 'TOWING WEIGHTS', page 246.

Exceeding allowable loads will increase the risk of tyre or suspension failure, increase stopping distance, and adversely affect vehicle handling and stability.

DO NOT use the rear towing eyes to tow a trailer or caravan- serious damage to the vehicle may result.

Balancing the combination

To ensure optimum stability, it is essential that the trailer adopts a level aspect. In other words, the trailer must be level with the ground, with the towing hitch and trailer drawbar set at the same height (note the illustration at the top of page). This is particularly important when towing twin axle trailers! Adjust the height of the hitch point if necessary.

Points to remember

- When calculating the laden weight of the trailer, remember to include the weight of the trailer.
- The trailer nose weight plus the combined weight of the rear seat passengers and the vehicle's load carrying area must never exceed the GVW or the individual maximum axle loads.

NOTE: *When towing, the gross vehicle weight can be increased by a maximum of 100 kg, provided road speed is limited to 100 km/h (60 mph). See 'VEHICLE WEIGHTS', page 245.*

- Where the luggage load can be divided between trailer and tow vehicle, loading more weight into the vehicle will generally improve the stability of the combination. However, ensure that the GVW and maximum rear axle load are not exceeded and that the combination remains level.

Towing

- For maximum stability, ensure that loads are securely anchored and unable to shift position during transit. Also, position loads so that most of the weight is placed close to the floor and, where possible, immediately above or close to the trailer axle(s).
- If the loaded trailer weight exceeds the maximum trailer weight, (see '*TOWING WEIGHTS*', page 246), the towing vehicle payload **MUST BE RESTRICTED** by at least the same amount to ensure that the GVW and rear axle load are not exceeded. This will require passengers and/or luggage to be removed from the vehicle.
- Check that the correct trailer flasher unit is fitted to the fuse box (consult your dealer/authorised repairer) and check the operation of trailer brakes and lights.
- Towing regulations vary from country to country. Always ensure national regulations governing towing weights and speed limits are observed (refer to the relevant national motoring organisation for information). The vehicle's maximum permissible towed weight refers to its design limitations and NOT to any specific territorial restriction (see '*TOWING WEIGHTS*', page 246).

NOTE: When towing, do not exceed 100 km/h (60 mph).

Vehicle weights

When loading a vehicle to its maximum (GVW), take account of the load distribution to ensure that axle loads do not exceed the permitted maximum values. It is your responsibility to limit the vehicle load in such a way that neither the maximum axle loads nor the GVW are exceeded. The most accurate method of determining load distribution is by using a public weighbridge.

Nose weight should be approximately 7% of the actual trailer laden weight to maintain optimum stability. Nose weight can be measured using a proprietary brand of nose weight indicator.

Gear range selection

To avoid overheating the gearbox, it is not advisable to tow heavy trailer loads at prolonged speeds of less than 32 km/h (20 mph).

Towing on severe inclines

If a journey includes severe inclines and the Gross Train Weight (the maximum permissible weight of vehicle, plus trailer, see '*TOWING WEIGHTS*', page 246) is towed, ensure that the grille and radiator are free from obstruction and that only high quality fuel is used. This enables the engine and the cooling system to operate more efficiently.

Correct gear selection will improve vehicle performance: On vehicles with manual transmission, select the highest practical gear that can be maintained without causing the engine to labour. On vehicles fitted with automatic transmission, select 'D' (Drive) and, where possible, maintain a speed that minimises automatic gear changes.

If severe inclines are encountered when towing at high altitude and in a high ambient temperature (30°C (86°F) or greater), the effective Gross Train Weight will be reduced by up to 400 kg. (882 lb). Therefore, it may be necessary to reduce the vehicle and/or trailer weight to help counter the reduced engine performance caused by the thinner atmosphere experienced at high altitudes.

Towing

Trailer socket

The vehicle connector provides a 5 amp output, which must NOT be exceeded.

If it is required to exceed 5 amps, a 12S and a 13 pin accessory harness kit is available from your Land Rover Dealer/Authorised Repairer, increasing the output to 15 amps.

ESSENTIAL TOWING CHECKS

| | |
|--|--|
| Nose weight | It is recommended that the nose weight should be approximately 7% of gross caravan/trailer weight up to maximum of 140 kg (310 lb). If the vehicle is loaded to the Gross Vehicle Weight (GVW), the nose weight is limited to 140 kg (310 lb). |
| Breakaway cable or secondary coupling | A breakaway cable or secondary coupling MUST be attached. If the trailer/caravan is fitted with brakes, it is usual for an attached breakaway cable to operate the brakes in the event of the coupling becoming detached. See your trailer manufacturers literature. If your trailer does not have a breakaway cable, a secondary coupling must be attached. Use a suitable point on the towing bracket to securely attach the coupling. It is not advisable to loop cables or couplings around the neck of the tow ball as they could slide off. |

TOW BARS

WARNING

Only fit towing accessories that have been approved by Land Rover.



Off-Road Driving

Off-Road Driving

| | |
|---------------------------------|-----|
| BEFORE YOU DRIVE | 155 |
| BASIC OFF-ROAD TECHNIQUES | 155 |
| AFTER DRIVING OFF-ROAD | 158 |
| SERVICING REQUIREMENTS | 158 |

Driving Techniques

| | |
|---|-----|
| DRIVING ON SOFT SURFACES & DRY SAND ... | 159 |
| DRIVING ON SLIPPERY SURFACES (ice, snow, mud, wet grass) | 159 |
| CLIMBING STEEP SLOPES | 160 |
| DESCENDING STEEP SLOPES | 161 |
| TRAVERSING A SLOPE | 161 |
| NEGOTIATING A 'V' SHAPED GULLY | 162 |
| DRIVING IN EXISTING WHEEL TRACKS | 162 |
| CROSSING A RIDGE | 162 |
| CROSSING A DITCH | 162 |
| WADING | 163 |

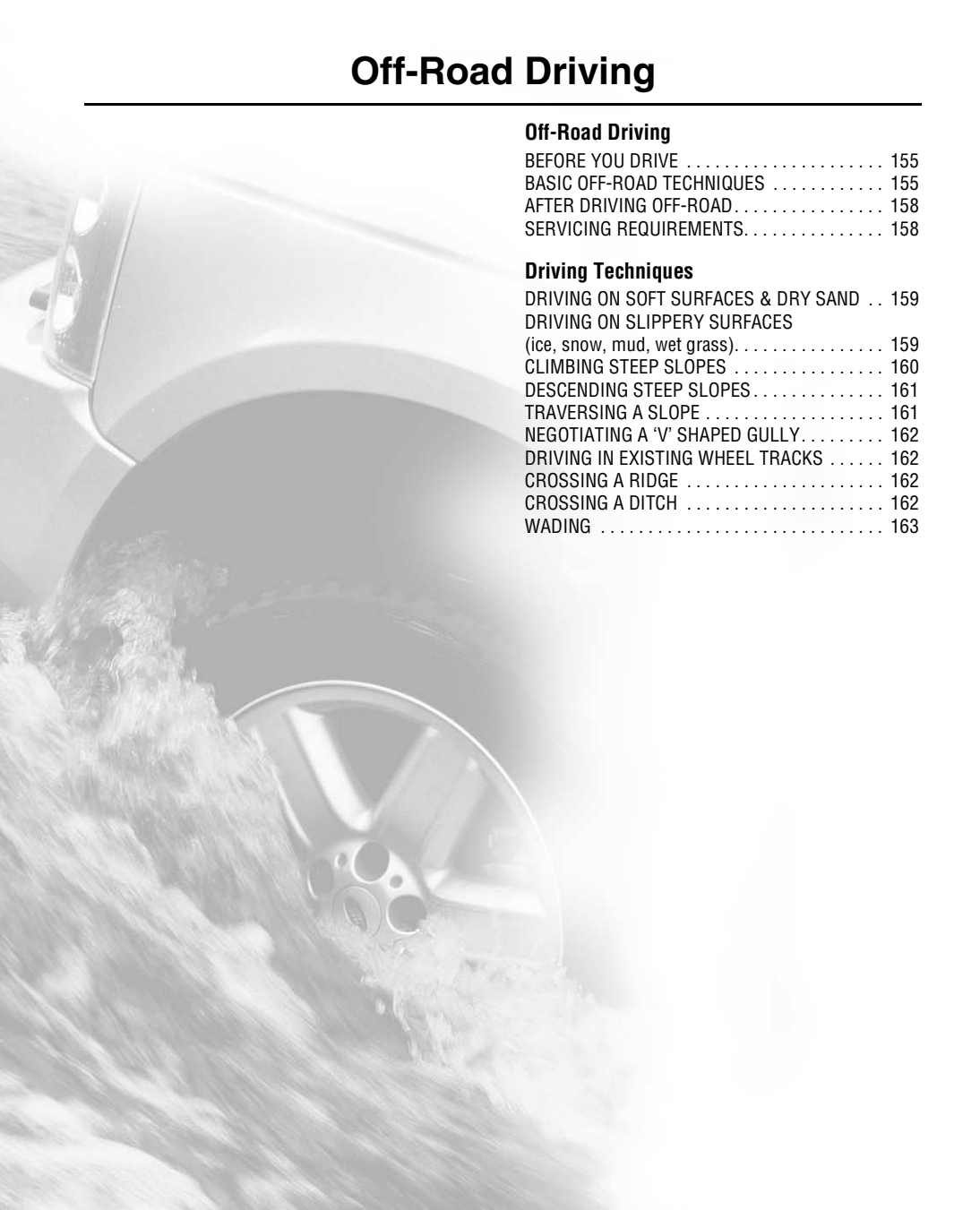



Off-Road Driving

BEFORE YOU DRIVE

Before venturing off-road, it is **absolutely essential** that inexperienced drivers become fully familiar with the vehicle's controls and also study the off-road driving techniques described on the following pages.

WARNING

Off-road driving can be hazardous!

- ***Familiarise yourself with the recommended driving techniques in order to minimise risks to yourself, your vehicle AND your passengers.***
 - ***DO NOT take unnecessary risks and be prepared for emergencies at all times.***
-

IMPORTANT

- Always wear a seat belt for personal protection in all off-road driving situations.
- DO NOT drive if the fuel level is low - undulating ground and steep inclines could cause fuel starvation to the engine and consequent damage to the catalytic converter.
- DO NOT stop the engine while driving through water (wading) - water ingress to the exhaust tailpipe could result in severe damage to the catalytic converter.

BASIC OFF-ROAD TECHNIQUES

These basic driving techniques are an introduction to the art of off-road driving and do not necessarily provide the information needed to successfully cope with every single off-road situation.

We strongly recommend that owners who intend to drive off-road frequently, should seek as much additional information and practical experience as possible.

Before driving off-road it is important that you check the condition of the wheels and tyres and that the tyre pressures are correct. Worn or incorrectly inflated tyres will adversely affect the performance, stability and safety of the vehicle.

Gear selection - manual gearbox

Correct gear selection is possibly the single most important factor for safe and successful off-road driving. While only experience will tell you which is the correct gear for any section of ground, the following basic rules apply:

- NEVER change gear or operate the clutch while negotiating difficult terrain - the drag on the wheels may cause the vehicle to stop when the clutch is depressed and restarting may be difficult.
- Generally, and especially where slippery or soft ground conditions prevail, the higher the gear you select the better.
- When descending very steep slopes, always select first gear and Hill Descent Control (HDC).

Inexperienced drivers are advised to stop the vehicle (on firm ground) and carefully consider which gear will be most appropriate for each manoeuvre before continuing.

Off-Road Driving

Slipping the clutch

Use of excessive clutch slip to prevent the engine stalling will result in premature clutch wear. Always select a gear low enough to enable the vehicle to proceed without needing to slip the clutch.

DO NOT drive with your foot resting on the clutch pedal; driving across uneven terrain could cause you to inadvertently depress the clutch, resulting in loss of control of the vehicle.

Gear selection - automatic gearbox

On automatic models, with the main selector lever set at 'D', the gearbox automatically provides the correct gear for the majority of off-road conditions. Remember that position '1' will hold the gearbox in first gear to give maximum engine braking when required.

When descending very steep slopes, always select position '1' and Hill Descent Control (HDC).

Braking

As far as possible, vehicle speed should be controlled through correct gear selection and the use of Hill Descent Control (HDC).

Application of the brake pedal should be kept to a minimum. In fact, if the correct gear and HDC have been selected, braking will be largely unnecessary.

If the brake pedal is depressed when HDC is active, HDC is overridden and the brakes will perform as normal. If the brake pedal is then released, HDC will recommence operating, if necessary.

Hill descent control (HDC)

During a descent, if engine braking is insufficient to control the vehicle speed, HDC (if selected) automatically operates the brakes to slow the vehicle and maintain a speed relative to the accelerator pedal position

When driving off-road, HDC can be permanently engaged, to ensure that control is maintained whenever 1st or reverse gears ('1' or 'R' for automatic transmission) are selected. ABS and Traction control are still fully operational and will assist if the need arises.

NOTE: *With HDC selected, gear changes can be carried out in the normal way.*

Accelerating

Use the accelerator with care - any sudden surge of power may induce wheel spin and, therefore, invoke unnecessary operation of traction control, or in extreme conditions could lead to loss of control of the vehicle.

Off-Road Driving

Steering

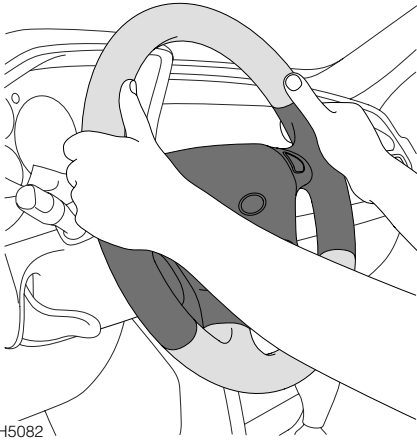

WARNING

DO NOT hold the steering wheel with your thumbs inside the rim - a sudden 'Kick' of the wheel as the vehicle negotiates a rut or boulder could seriously injure them. ALWAYS grip the wheel on the outside of the rim (as shown) when traversing uneven ground.

Survey the ground before driving

Before negotiating difficult terrain, it is wise to carry out a preliminary survey on foot. This will minimise the risk of your vehicle getting into difficulty through a previously unnoticed hazard.

Ground clearance

Don't forget to allow for ground clearance beneath the body and under the front and rear bumpers. Note that the suspension arms are situated below the body. Note also that there are other parts of the vehicle which may come into contact with the ground - take care not to ground the vehicle.

Ground clearance is particularly important at the bottom of steep slopes, or where wheel ruts are unusually deep and where sudden changes in the slope of the ground are experienced.

ALWAYS attempt to avoid obstacles that may foul the underside of the vehicle.

NOTE: 'Sport' model has reduced ground clearance.

Loss of traction

If the vehicle is immobilised due to loss of wheel grip, the following hints could be of value:

- Avoid prolonged wheel spin; this will only make matters worse.
- Remove obstacles rather than forcing the vehicle to cross them.
- Clear clogged tyre treads.
- Reverse as far as possible, then attempt an increased speed approach - additional momentum may overcome the obstacle.
- Brushwood, sacking or any similar material placed in front of the tyres may improve tyre grip.

CD autochanger*

Playing CDs while negotiating arduous off-road terrain is not recommended. Severe jolting of the vehicle may disturb the operation of the autochanger, causing the disc to 'jump or skip'.

Off-Road Driving

AFTER DRIVING OFF-ROAD

IMPORTANT

Before rejoining the public highway, or driving at speeds above 40 km/h, consideration should be given to the following:

- Wheels and tyres must be cleaned of mud and inspected for damage.
- If wheels and tyres are not cleaned properly, damage to the wheels, tyres, braking system and suspension components could occur.
- Brake discs and callipers should be examined and any stones or grit that may affect braking efficiency removed.
- The underside of the vehicle should be checked for damage, especially the suspension air springs and dampers.
- Any damage to paint or protective coatings, should be rectified by a Land Rover Dealer/Authorised Repairer as soon as possible.

If you have any doubt whether the vehicle has been damaged, have the vehicle inspected by a Land Rover Dealer/Authorised Repairer.

SERVICING REQUIREMENTS

Vehicles operated in arduous conditions, particularly on dusty, muddy or wet terrain, and vehicles undergoing frequent or deep wading conditions will require more frequent servicing. See '*OWNER MAINTENANCE*', page 168 and contact a Land Rover Dealer/Authorised Repairer for advice.

After wading in salt water or driving on sandy beaches, use a hose to wash the underbody components and any exposed body panels with fresh water. This will help to protect the vehicle's cosmetic appearance.

Driving Techniques

DRIVING ON SOFT SURFACES & DRY SAND

The ideal technique for driving on soft sand requires the vehicle to be kept moving at all times - soft sand causes excessive drag on the wheels, resulting in a rapid loss of motion once driving momentum is lost. For this reason, gear changing (particularly on manual gearbox vehicles) should be avoided.

Select the highest suitable gear and REMAIN in that gear until a firm surface is reached.

Stopping the vehicle on soft ground, in sand or on an incline

If you do stop the vehicle, remember:

Starting on an incline or in soft ground or sand may be difficult. Always park on a firm level area, or with the vehicle facing downhill.

To avoid wheel spin, select second or third gear, ('D' for automatic gearbox), and use the MINIMUM throttle necessary to get the vehicle moving.

If forward motion is lost, avoid excessive use of the throttle - this will cause wheel spin and tend to dig the vehicle into the sand. Clear sand from around the tyres and ensure that the body is not bearing on the sand before again attempting to move.

If the wheels have sunk, use an air bag lifting device or high lift jack to raise the vehicle, and then build up sand under the wheels so that the vehicle is again on level ground. If a restart is still not possible, place sand mats or ladders beneath the wheels.

DRIVING ON SLIPPERY SURFACES (ice, snow, mud, wet grass)

- Select the highest gear possible.
- Drive away using the MINIMUM throttle possible.
- Drive slowly at all times, keeping braking to a minimum and avoiding violent movements of the steering wheel.

Driving Techniques

CLIMBING STEEP SLOPES

ALWAYS follow the fall line of the slope - travelling diagonally could encourage the vehicle to slide broadside down the slope.

Select 1st gear ('1' for automatic transmission) and engage hill descent control (HDC). If the surface is loose or slippery, use sufficient speed in the highest practical gear to take advantage of your vehicle's momentum. However, too high a speed over a bumpy surface may result in a wheel lifting, causing the vehicle to lose traction. In this case try a slower approach. Traction can also be improved by easing off the accelerator just before loss of forward motion.

If the vehicle is unable to complete a climb, do not attempt to turn it around while on the slope. Instead, adopt the following procedure to reverse downhill to the foot of the slope.

1. Hold the vehicle stationary using both foot and hand brakes.
2. Restart the engine if necessary.
3. Engage reverse gear ('R' for automatic transmission).
4. Select hill descent control (HDC), if not already selected.
5. Release the handbrake. Then release the foot brake and clutch (where applicable) simultaneously, and allow the vehicle to reverse down the slope using engine braking and HDC to control the rate of descent.
6. Unless it is necessary to stop the vehicle to negotiate obstructions, DO NOT apply the brake or clutch pedal during the descent.
7. If the vehicle begins to slide, accelerate slightly to allow the tyres to regain grip.

When the vehicle is back on level ground or where traction can be regained, a faster approach will probably enable the hill to be climbed. However, DO NOT take unnecessary risks, if the hill is too difficult to climb, find an alternative route.

WARNING

DO NOT attempt to reverse down a slope without the engine running, or HDC and the braking effect of the gearbox will be lost.

Driving Techniques

DESCENDING STEEP SLOPES

WARNING

Failure to follow these instructions may cause the vehicle to roll over.

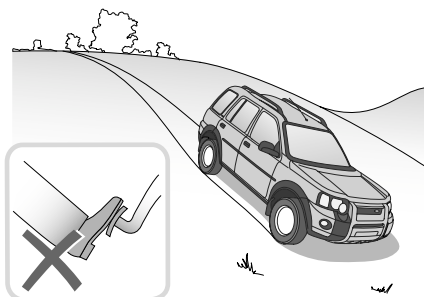

H5223

- Stop the vehicle at least a vehicle length before the start of the slope and engage first gear ('1', for automatic transmission) and hill descent control (HDC).
- Unless it is necessary to stop the vehicle in order to negotiate obstructions, DO NOT touch the brake or clutch pedals (where applicable) during the descent - the engine and HDC will limit the speed, keeping the vehicle under perfect control provided the front wheels are rotating. If the vehicle begins to slide, the limits of adhesion have been reached, and it may be impossible to maintain the minimum speed relative to the gear selected. In this case, HDC may automatically accelerate the vehicle sufficient to maintain directional stability. DO NOT use the accelerator or the brakes or attempt to change gear. HDC will automatically slow the vehicle down again as soon as possible.
- Once level ground is reached, select a suitable gear for the next stage of your journey.

TRAVERSING A SLOPE

WARNING

Failure to follow these instructions may cause the vehicle to roll over.

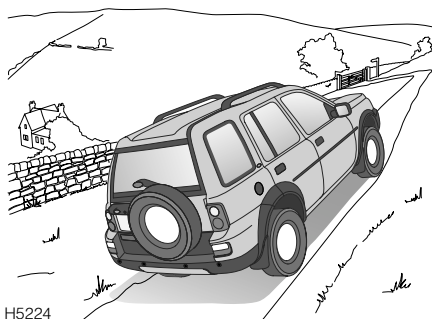

H5224

Before crossing a slope ALWAYS observe the following precautions:

- Check that the ground is firm and not slippery.
- Check that the wheels on the downhill side of the vehicle are not likely to drop into depressions in the ground and that the 'uphill' wheels will not run over rocks, tree roots, or similar obstacles that could suddenly increase the angle of tilt.
- Ensure that passenger weight is evenly distributed, that all roof rack luggage is removed and that all other luggage is properly secured and stowed as low as possible. Always remember; any sudden movement of the load could cause the vehicle to overturn.
- Rear seat passengers should sit on the uphill side of the vehicle or, in extreme conditions, should vacate the vehicle until the sloping ground has been safely negotiated.

Driving Techniques

NEGOTIATING A 'V' SHAPED GULLY

Observe extreme caution! Steering up either of the gully walls could cause the side of the vehicle to be trapped against the opposite gully wall.

DRIVING IN EXISTING WHEEL TRACKS

As far as possible allow the vehicle to steer itself along the bottom of the ruts. However, always keep a light hold of the steering wheel to prevent it from spinning free.

Particularly in wet conditions, if the steering wheel is allowed to spin free, the vehicle may appear to be driving straight ahead in the ruts, but in actual fact (due to the lack of traction caused by the wet ground) is unknowingly on full right or left lock. Then, when level ground is reached, or if a dry patch of ground is encountered, the wheels will find traction and cause the vehicle to suddenly veer to left or right.

CROSSING A RIDGE

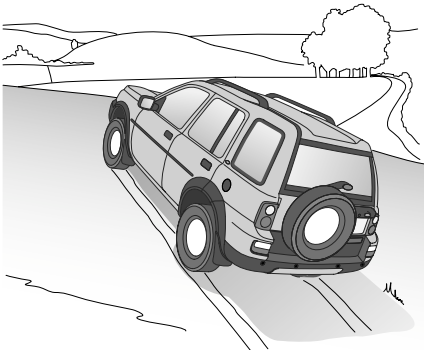

H5225

Approach at right angles so that both front wheels cross the ridge together - an angled approach could cause diagonally opposite wheels lifting from the ground at the same time.

CROSSING A DITCH



H5226

Cross ditches at an angle so that three wheels always maintain contact with the ground. If a ditch is approached head on, both front wheels will drop into the ditch together, possibly resulting in the body and front bumper being trapped on opposite sides of the ditch.

Driving Techniques

WADING



H5229

WARNING

The maximum advisable wading depth is 0,4 m.

Severe electrical damage may occur if the vehicle remains stationary for any length of time when the water level is above the door sills.

Severe damage to the catalytic converter could occur if the engine is stopped for any length of time when the water level is above the exhaust tailpipe.

If the depth of water is likely to exceed 0,4 m, the following precautions should be observed:

- Fix a plastic sheet in front of the radiator grille to prevent water from soaking the engine and mud from blocking the radiator.
- Remove the CD autochanger*
- Ensure that the silt bed beneath the water is free of obstacles and firm enough to support the vehicle's weight and provide sufficient traction.
- Ensure that the engine air intake is clear of the water level.
- Select a low gear and maintain sufficient throttle to prevent the engine from stalling. This is particularly important if the exhaust pipe is under water.

- Drive slowly into the water and accelerate to a speed which causes a bow wave to form; then maintain that speed.

At all times, keep all the doors fully closed.

After wading

- Drive the vehicle a short distance and apply the foot brake to check that the brakes are fully effective.
- DO NOT rely on the handbrake to hold the vehicle stationary until the brakes are thoroughly dried out; in the meantime, leave the vehicle parked in gear ('P' for automatic gearbox vehicles).
- Remove any protective covering from in front of the radiator grille.
- If the water was particularly muddy, remove any blockages (mud and leaves) from the radiator to reduce the risk of overheating.
- If deep water is regularly negotiated, check all oils for signs of water contamination - contaminated oil can be identified through its 'milky' appearance. In addition, check the air filter element for water ingress and replace if wet - consult a Land Rover Dealer/Authorise Repairer if necessary.
- If salt water is frequently negotiated, thoroughly wash the underbody components and exposed body panels with fresh water.

NOTE: Vehicles required to undergo frequent or deep wading conditions will require more frequent servicing. Contact a Land Rover Dealer/Authorised Repairer for advice.



Owner Maintenance

Maintenance

| | |
|--|-----|
| ROUTINE MAINTENANCE | 167 |
| OWNER MAINTENANCE | 168 |
| SAFETY IN THE GARAGE | 169 |
| EMISSION CONTROL | 170 |
| ROAD TESTING DYNAMOMETERS (‘rolling roads’) | 170 |

Bonnet Opening

| | |
|----------------------|-----|
| BONNET OPENING | 171 |
|----------------------|-----|

Engine Compartment

| | |
|-------------------------|-----|
| 2.0 DIESEL ENGINE | 172 |
| 1.8 PETROL ENGINE | 173 |
| 2.5 PETROL ENGINE | 174 |

Engine

| | |
|------------------|-----|
| ENGINE OIL | 175 |
|------------------|-----|

Cooling System

| | |
|------------------------------|-----|
| COOLANT CHECK & TOP-UP | 176 |
| ANTI-FREEZE | 177 |

Brakes

| | |
|-------------------|-----|
| BRAKE FLUID | 178 |
|-------------------|-----|

Power Steering

| | |
|----------------------------|-----|
| POWER STEERING FLUID | 180 |
|----------------------------|-----|

Washers

| | |
|--------------------------|-----|
| WINDSCREEN WASHERS | 181 |
|--------------------------|-----|

Wiper Blades

| | |
|-------------------------------|-----|
| WIPER BLADE REPLACEMENT | 182 |
|-------------------------------|-----|

Battery

| | |
|---|-----|
| BATTERY SAFETY | 183 |
| BATTERY MAINTENANCE | 183 |
| THE EFFECTS OF BATTERY DISCONNECTION .. | 186 |

Tyres

| | |
|-----------------------------|-----|
| CARING FOR YOUR TYRES | 187 |
| SNOW CHAINS | 189 |

Cleaning & Vehicle Care

| | |
|----------------------------|-----|
| WASHING YOUR VEHICLE | 190 |
|----------------------------|-----|



CLEANING THE INTERIOR 193

Identification Numbers

CONTACTING YOUR DEALER 195

IDENTIFICATION NUMBER LOCATIONS 195

VEHICLE IDENTIFICATION NUMBER 196

Parts & Accessories

PARTS AND ACCESSORIES 197

Maintenance

ROUTINE MAINTENANCE

Regular systematic maintenance is the key to ensuring the continued reliability and efficiency of your vehicle.

Maintenance is the owner's responsibility and you must ensure that owner maintenance operations, brake fluid and coolant changes are carried out when required and according to the manufacturer's recommendations.

The routine maintenance requirements for your vehicle are shown in the Service Portfolio book. Most of this necessary workshop maintenance requires specialised knowledge and equipment, and should preferably be entrusted to a Land Rover Dealer/Authorised Repairer.

Service Portfolio

The Service Portfolio book includes a Service Record section, which enables a record to be kept of all services that are carried out on the vehicle. This section of the book also provides a facility for the Dealer/Authorised Repairer to record brake fluid and camshaft drive belt changes, as well as the fitting of replacement airbag modules.

Ensure your Dealer/Authorised Repairer signs and stamps the book after each service.

Brake fluid and coolant replacement

The brake fluid and engine coolant (anti-freeze and water solution) needs to be replaced every 60,000 km or 36 months, whichever is the sooner.

Your Dealer/Authorised Repairer will replace the brake fluid and coolant at the scheduled services.

Maintenance

OWNER MAINTENANCE

In addition to the routine services referred to previously, a number of simple checks must be carried out more frequently. You can carry out these checks yourself and advice is given on the pages that follow.

Any significant or sudden drop in fluid levels, or uneven tyre wear, should be reported to a dealer without delay.

Daily checks

- Operation of lights, horn, direction indicators, wipers, washers and warning lights.
- Operation of seat belts and brakes.
- Look for fluid deposits underneath the vehicle that might indicate a leak.

Weekly checks (or every 400 km)

- Engine oil level.
NOTE: The engine oil level should be checked more frequently if the vehicle is driven for prolonged periods at high speeds.
- Coolant level.
- Screen washer fluid level.
- Tyre pressures and condition.
- Operate air conditioning*.

Monthly checks

- Brake fluid level.
- Power steering fluid level.

Driving in arduous conditions

IMPORTANT INFORMATION

Special operation conditions

When a vehicle is operated in extremely arduous conditions, more frequent attention must be paid to servicing requirements.

For example: if your vehicle experiences deep wading conditions, even DAILY servicing could be necessary to ensure the continued safe and reliable operation of the vehicle.

Arduous driving conditions include:

- Repeated short distance driving (e.g. up to 8 km), stop-start driving or idling for long periods.
- Driving in dusty and/or sandy conditions.
- Driving on rough and/or muddy roads and/or wading.
- Driving in extremely hot conditions.
- Towing a trailer or driving in mountainous conditions.

Contact a Land Rover Dealer/Authorised Repairer for advice.

Maintenance

SAFETY IN THE GARAGE

WARNING

Cooling fans may continue to operate after the engine is switched off. When the engine is hot, the cooling fans may also COMMENCE operating after the engine is switched off and continue operating for up to 8 minutes. Keep clear of all fans while working in the engine compartment.

If you need to carry out maintenance, observe the following safety precautions at all times:

- *Keep your hands and clothing away from drive belts and pulleys.*
 - *If the vehicle has been driven recently, DO NOT TOUCH exhaust and cooling system components until the engine has cooled.*
 - *DO NOT TOUCH electrical leads or components while the engine is running, or with the starter switch turned on.*
 - *NEVER leave the engine running in an unventilated area - exhaust gases are poisonous and extremely dangerous.*
 - *DO NOT work beneath the vehicle with the wheel changing jack as the only means of support.*
 - *Ensure sparks and naked lights are kept away from the engine compartment.*
 - *Wear protective clothing, including, where practicable, gloves made from an impervious material.*
 - *Remove metal wrist bands and jewellery before working in the engine compartment.*
 - *DO NOT allow tools or metal parts of the vehicle to make contact with the battery leads or terminals.*
-

WARNING

Under no circumstances should any part of the fuel system be dismantled or replaced by anyone other than a suitably qualified motor vehicle technician. Failure to comply with this instruction may result in fuel spillage with a consequent serious risk of fire.

Poisonous fluids

Fluids used in motor vehicles are poisonous and should not be consumed or brought into contact with open wounds. These include; battery acid, anti-freeze, brake and power steering fluid, petrol, diesel, engine oil and windscreen washer additives.

For your own safety, ALWAYS read and obey all instructions printed on labels and containers.

Used engine oil

Prolonged contact with engine oil may cause serious skin disorders, including dermatitis and cancer of the skin. ALWAYS wash thoroughly after contact.



It is illegal to pollute drains, water courses or soil. Use authorised waste disposal sites to dispose of used oil and toxic chemicals.

Maintenance

EMISSION CONTROL

Your vehicle is fitted with various items of emission and evaporative control equipment designed to meet specific territorial requirements. You should be aware that unauthorised replacement, modification or tampering with this equipment by an owner or repair shop may be unlawful and subject to legal penalties.

In addition, engine settings must not be tampered with. These have been established to ensure that your vehicle complies with stringent exhaust emission regulations.

Incorrect engine settings may adversely affect exhaust emissions, engine performance and fuel consumption, as well as causing high temperatures, which will result in damage to the catalytic converter and the vehicle.

ROAD TESTING DYNAMOMETERS (‘rolling roads’)

Because your vehicle is equipped with anti-lock brakes and permanent four-wheel drive, it is essential that any dynamometer testing is carried out **ONLY** by a qualified person familiar with the dynamometer testing and safety procedures practiced by Land Rover Dealers/Authorised Repairers. Contact your Land Rover Dealer/Authorised Repairer for further information.

Bonnet Opening

BONNET OPENING

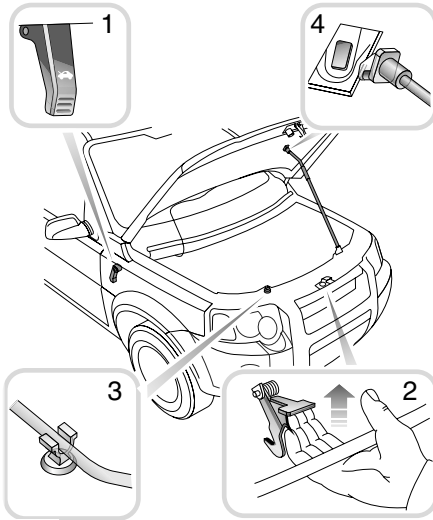

H5126

1. From inside the vehicle on the right hand side, pull the bonnet release handle (see illustration).
2. Lift the bonnet safety catch lever and raise the bonnet.
3. Unclip the bonnet support stay.
4. Fit the support stay into the cut-out in the underside of the bonnet.

Closing the bonnet

WARNING

DO NOT drive with the bonnet retained by the safety catch alone.

Replace the support stay in its retaining clip, then lower the bonnet, allowing it to drop for the last 30 cm approx.

After closing the bonnet, check that the lock is fully engaged by attempting to lift the front edge of the bonnet. This should be free from all movement.

Engine Compartment

2.0 DIESEL ENGINE

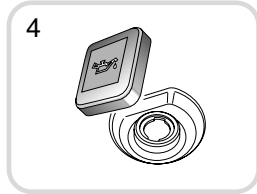
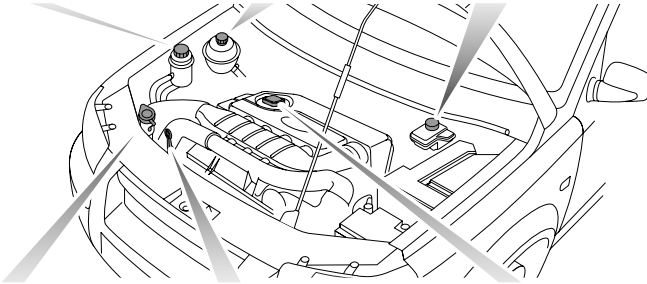
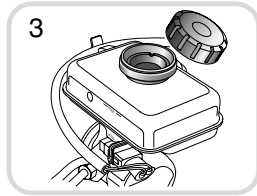
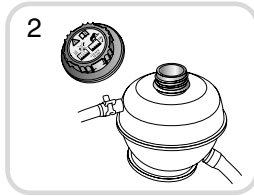
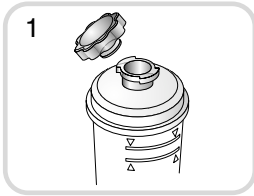

H5127

1. Power steering reservoir.
2. Cooling system reservoir.
3. Brake fluid reservoir.
4. Engine oil filler cap.
5. Engine oil dipstick (yellow).
6. Washer reservoir.

WARNING

While working in the engine compartment, ALWAYS observe the safety precautions listed under 'SAFETY IN THE GARAGE', page 169.

Engine Compartment

1.8 PETROL ENGINE

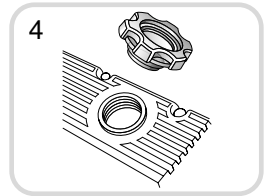
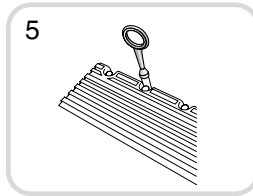
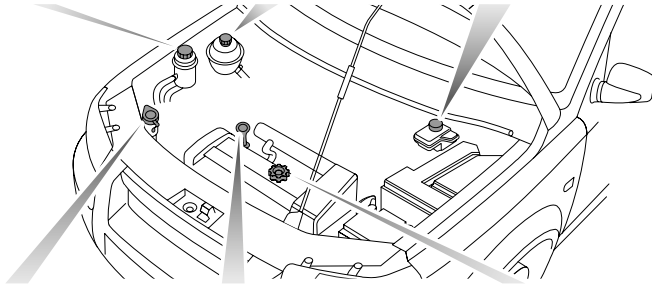
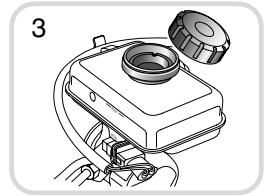
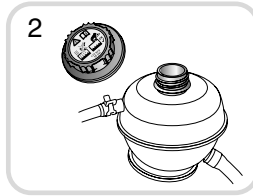
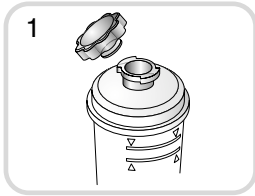

H5129

1. Power steering reservoir.
2. Cooling system reservoir.
3. Brake fluid reservoir.
4. Engine oil filler cap.
5. Engine oil dipstick.
6. Washer reservoir.

WARNING

While working in the engine compartment, ALWAYS observe the safety precautions listed under 'SAFETY IN THE GARAGE', page 169'.

Engine Compartment

2.5 PETROL ENGINE

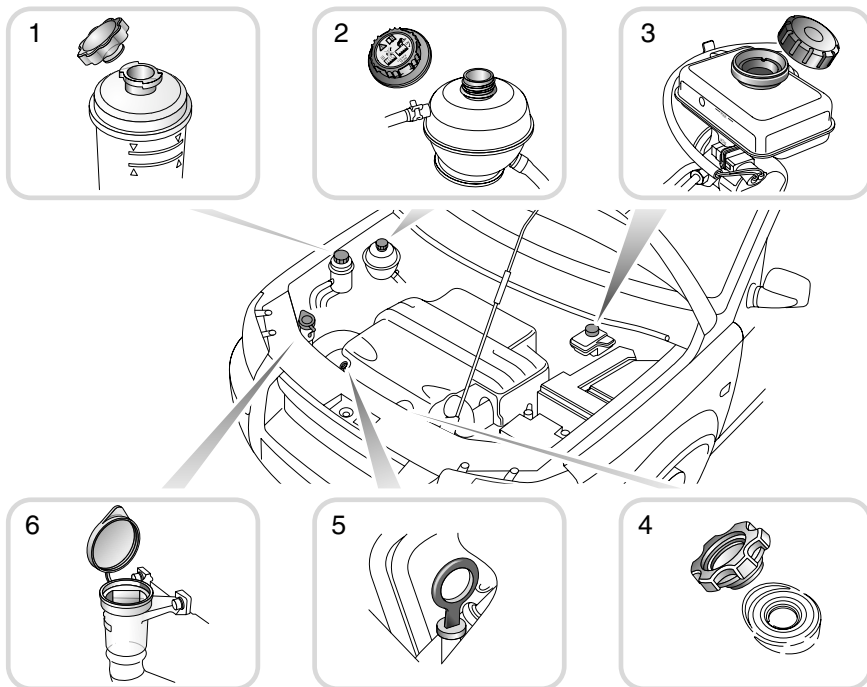

H5131

1. Power steering reservoir.
2. Cooling system reservoir.
3. Brake fluid reservoir.
4. Engine oil filler cap.
5. Engine oil dipstick.
6. Washer reservoir.

WARNING

While working in the engine compartment, ALWAYS observe the safety precautions listed under 'SAFETY IN THE GARAGE', page 169.

Engine

ENGINE OIL

Oil specification

See 'LUBRICANTS AND FLUIDS', page 233.

Oil level check & top-up

WARNING

Take care to avoid spilling engine oil onto a hot engine - a fire may result! Wipe up any spillage immediately.

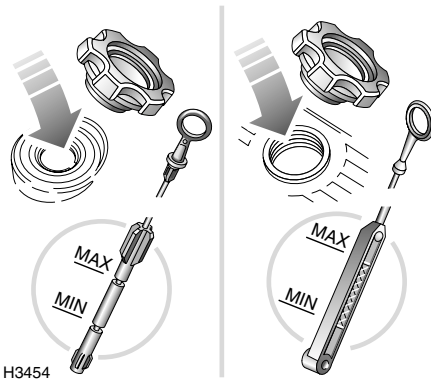

Petrol engines

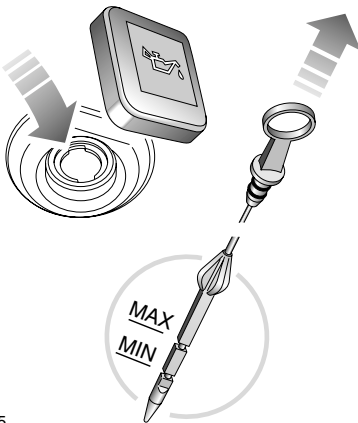

H3455

Diesel engines

1. Withdraw the dipstick and wipe the blade clean.
2. Slowly insert the dipstick and withdraw again to check the level, which should NEVER be allowed to fall below the lower mark on the dipstick.
3. To top-up, remove the oil filler cap and add oil to maintain a level between the upper and lower marks on the dipstick. As a general guide, if the level on the dipstick is:
 - nearer to the upper mark than the lower, add no oil.
 - nearer to the lower mark than the upper, add half a litre of oil.
 - at or below the lower mark, add one litre of oil.

WARNING

Driving the vehicle with the engine oil level ABOVE the upper mark, or BELOW the lower mark on the dipstick, will damage the engine.

4. Wait for five minutes and then recheck the level, adding more oil if necessary - DO NOT OVERFILL!
5. Finally, ensure the dipstick and filler cap are replaced.

NOTE: If oil consumption seems excessive, check the system for leaks and contact your Dealer/Authorised Repairer.

Check the oil level weekly, or every 400 km. Ideally the oil level should be checked with the engine cold and the vehicle resting on level ground. If the engine is already warm, then wait for at least two minutes after switching off before checking the level.

NOTE: Check the engine oil more frequently if the vehicle is driven at high speeds for prolonged periods.

Cooling System

COOLANT CHECK & TOP-UP

WARNING

NEVER remove the filler cap when the engine is hot -escaping steam or scalding water could cause serious personal injury.

Unscrew the filler cap slowly, allowing the pressure to escape before removing completely.

NEVER run the engine without coolant.

Anti-freeze will damage painted surfaces; soak up any spillage with an absorbent cloth immediately and wash the area with a mixture of car shampoo and water.

NEVER top-up with salt water. When travelling in territories where the water supply contains salt, always ensure you carry a supply of fresh (rain or distilled) water.

Avoid spilling anti-freeze onto a hot engine - a fire may result.

The coolant level in the expansion tank should be checked at least weekly (more frequently in high mileage or arduous operating conditions). Always check the level WHEN THE SYSTEM IS COLD and with the vehicle resting on level ground.

If it is necessary to remove the filler cap before the system has fully cooled, loosen the cap slowly, allowing the air pressure to escape gradually.

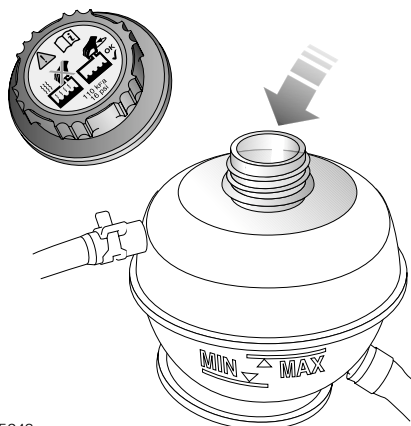

H5243

Top-up with a 50% mixture of anti-freeze and water so that the surface of the coolant is level with the 'MAX' indicator on the side of the tank. See 'LUBRICANTS AND FLUIDS', page 233.

Ensure the cap is tightened fully after top-up is completed. The cap has a distinctive 'ratchet click', tighten until three clicks are heard.

If the coolant level has fallen appreciably, suspect leakage or overheating and arrange for your Dealer/Authorised Repairer to examine the vehicle.

NOTE: DO NOT add rust inhibitors or other additives to the coolant - these may not be compatible with the coolant or engine components.

If the cooling system is to be topped-up before the vehicle is left undriven over the winter, mix the anti-freeze and water together thoroughly BEFORE adding it to the cooling system.

Cooling System

ANTI-FREEZE

WARNING

Anti-freeze is poisonous and can be fatal if swallowed - keep containers sealed and out of the reach of children. If accidental consumption is suspected, seek medical attention immediately.

Prevent anti-freeze coming in contact with the skin or eyes. If this occurs, rinse immediately with plenty of water.

Anti-freeze contains important corrosion inhibitors. The anti-freeze content of the coolant must be maintained at 50% ± 5% all year round (not just in cold conditions). To ensure that the anti-corrosion properties of the coolant are retained, the anti-freeze content should be checked once a year (regardless of mileage) and completely renewed every 3 years or 60,000 km, whichever is the sooner. Failure to do so may cause corrosion of the radiator and engine components.

The specific gravity of a 50% anti-freeze solution at 20°C (68°F) is 1.075 and protects against frost down to -36°C (-33°F).

Coolant specification

See 'LUBRICANTS AND FLUIDS', page 233.

In an emergency - and only if this type of anti-freeze is unavailable - top-up the cooling system with clean water, but be aware of the resultant reduction in frost protection. DO NOT top-up or refill with conventional anti-freeze formulations. If in doubt consult a Land Rover Dealer/Authorised Repairer.

Brakes

BRAKE FLUID

WARNING

Brake fluid is highly toxic - keep containers sealed and out of the reach of children. If accidental consumption of fluid is suspected, seek medical attention immediately.

If brake fluid should come into contact with the skin or eyes, rinse immediately with plenty of water.

Take care not to spill fluid onto a hot engine - a fire may result.

DO NOT drive the vehicle with the fluid level below the 'MIN' mark.

Brake fluid will damage painted surfaces; soak up any spillage with an absorbent cloth immediately and wash the area with a mixture of car shampoo and water.

NOTE: Brake fluid must be completely renewed every 60,000 km or 36 months, whichever is the sooner.

Check

The fluid level may fall slightly during normal use as a result of brake pad wear but should not be allowed to fall below the 'MIN' mark. If there is any appreciable drop in level over a short period, consult your Dealer/Authorised Repairer. **DO NOT drive if the fluid level is below the minimum mark on the reservoir.**

WARNING

Contact your Dealer/Authorised Repairer immediately if brake pedal travel is unusually long or if there is any appreciable drop in brake fluid level.

With the vehicle on level ground, check the fluid level at least every week (more frequently in high mileage or arduous operating conditions). Check the level visually through the side of the transparent reservoir without removing the filler cap.

Brake fluid specification

See 'LUBRICANTS AND FLUIDS', page 233.

Brakes

Top-up

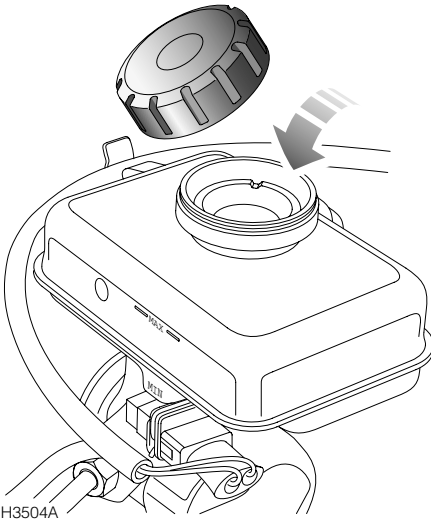

Wipe the filler cap clean before removing, to prevent dirt from entering the reservoir. Unscrew the cap and top-up the reservoir to the 'MAX' mark using a recommended fluid.

Use only new fluid from an airtight container (old fluid from opened containers or fluid previously bled from the system will have absorbed moisture, which will adversely affect performance, and must NOT be used). **DO NOT OVERFILL!**

Power Steering

POWER STEERING FLUID

WARNING

Power steering fluid is highly toxic - keep containers sealed and out of reach of children. If accidental consumption of fluid is suspected, seek medical attention immediately.

If power steering fluid should come into contact with the skin or eyes, rinse immediately with plenty of water.

Power steering fluid will damage painted surfaces: Soak up any spillage with an absorbent cloth immediately and wash the area with a mixture of car shampoo and water.

Take care not to spill power steering fluid onto a hot engine - a fire may result. Wipe up any spillage immediately.

Check and Top-up

Check and top-up the fluid level ONLY when the engine is cold. You should also ensure that the front wheels are in the straight ahead position before stopping the engine and checking the fluid level.

Check the fluid level against the marks on the side of the reservoir.

If more fluid is needed, first wipe the filler cap clean to prevent dirt from entering the reservoir, then twist the cap a quarter turn anti-clockwise and pull to remove.

Top up the reservoir to the upper level mark using a recommended fluid. **DO NOT OVERFILL!**

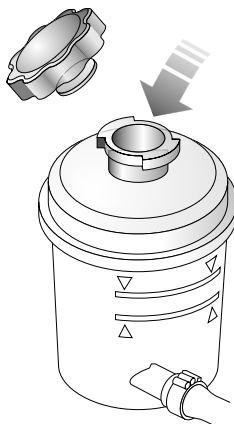

H5244

Emergency operation

Any large or sudden drop in the fluid level must be investigated by a qualified Dealer/Authorised Repairer.

If it can be established that fluid loss is slow, then the reservoir may be topped-up to the upper level mark to enable the vehicle to be driven to the nearest qualified Dealer/Authorised Repairer for examination.

If the fluid level has dropped below the lower level mark, top-up the reservoir before starting the engine, or damage to the steering pump could result.

Fluid specification

See 'LUBRICANTS AND FLUIDS', page 233.

Oils manufactured to the above specifications are suitable for use in temperatures between -20°C to +30°C (if climatic temperature falls outside these limits, seek advice from your Dealer/Authorised Repairer).

NOTE: *The colour of commercially available fluids may differ from that of the power steering fluid used to fill the system during manufacture. This is not cause for concern.*

Washers

WINDSCREEN WASHERS

Fluid top-up

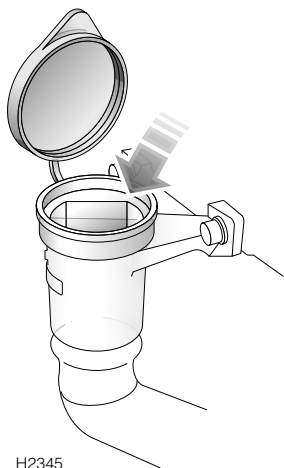

H2345

The windscreen washer reservoir supplies both front and rear screen washer jets.

Check the reservoir level at least every week and to prevent freezing in cold weather, top-up with a mixture of water and LR Parts STC 8249 Screenwash.

Preferably mix the recommended quantities of water and screenwash in a separate container before topping-up the system, and always follow the instructions on the screenwash container.

WARNING

Some screenwash products are inflammable, particularly if high or undiluted concentrations are exposed to sparking. DO NOT allow screenwash to come into contact with naked flames or sources of ignition.

Body panels may suffer discoloration as a result of screenwash spillage. Take care to avoid spillage, particularly if an undiluted or high concentration of screenwash is being used. If spillage occurs, wash the affected area immediately with water.

DO NOT use an anti-freeze or vinegar/water solution in the washer reservoir - anti-freeze will damage painted surfaces, while vinegar can damage the windscreen washer pump.

Washer jets

Operate the washer switches periodically to check that the nozzles are clear and properly directed.

The windscreen washer jets are set during manufacture and should not need adjusting. However, if adjustment is ever necessary, insert a needle into the jet orifice and lever gently to position each jet so that the spray is directed towards the centre of the windscreen.

Should a windscreen washer jet become obstructed, insert a needle or thin strand of wire into the orifice to clear the blockage.

NOTE: *The rear screen washer jet is integral with the wiper arm and requires no adjustment.*

Wiper Blades

WIPER BLADE REPLACEMENT

IMPORTANT

- Grease, silicone and petrol based products impair the blade's wiping capability. Wash the wiper blades in warm soapy water and periodically check their condition.
- If signs of hardness or cracking in the rubber are found, or if the wipers leave streaks or unwiped areas on the windscreen during use, then the wiper blades should be replaced.
- Clean the windscreen regularly with an approved glass cleaner and ensure the screen is thoroughly cleaned before fitting replacement wiper blades.

Front wiper blades

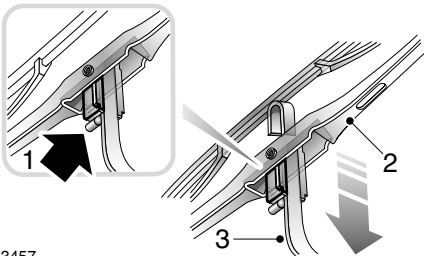

H3457

Lift the wiper arm away from the windscreen. With the blade at 90° to the arm as shown, disconnect the blade by pushing in the locking tab (1) and sliding the blade (2) down the arm (3).

Fitting a replacement blade is a reversal of this process; position the new blade assembly on the wiper arm and slide the blade fully towards the hooked end of the arm until it locks in place. Check that the blade is securely locked before returning the wiper assembly to the windscreen.

Only fit replacement wiper blades that are identical to the original specification.

Rear wiper blades

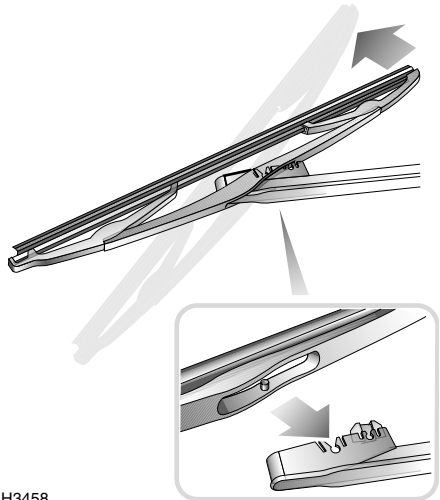

H3458

Lift the wiper arm away from the rear screen, as far as the spare wheel carrier will allow. Pivot the blade assembly away from the arm (as arrowed), levering against resistance, until the two retaining lugs detach from their slots at the end of the arm. Carefully replace the arm to its stowed position.

To replace, position the wiper arm into the aperture in the middle of the blade assembly, line up the retaining lugs with the corresponding slots in the wiper arm and push firmly into position until the blade clips into place.

Battery

BATTERY SAFETY

WARNING

Batteries contain sulphuric acid, which is both corrosive and poisonous. If spillage occurs:

- *On clothing or the skin - remove any contaminated clothing immediately, flush the skin with large amounts of water, and seek medical attention urgently.*
- *In the eyes - flush with clean water immediately for at least 15 minutes. Seek medical attention urgently.*
- *Swallowing battery acid can be fatal unless IMMEDIATE action is taken - seek medical attention urgently.*

During normal operation batteries emit explosive hydrogen gas - ensure sparks and naked lights are kept away from the engine compartment.

For your safety, remove all metal wrist bands and jewellery before working in the engine compartment and NEVER allow the battery terminals or vehicle leads to make contact with tools or metal parts of the vehicle.

BATTERY MAINTENANCE

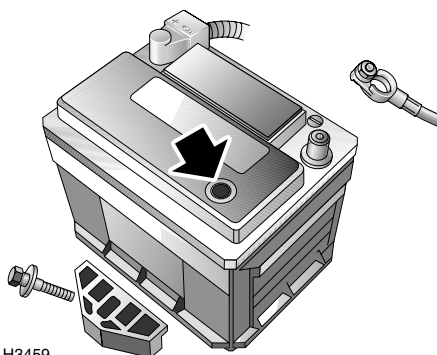

H3459

The battery is designed to be maintenance free, so topping-up is unnecessary. On the top of the battery there is a battery condition indicator (arrowed in illustration). Examine the indicator periodically to check the battery's condition. When the indicator shows:

- GREEN - the battery is in a good state of charge.
- DARK (turning to black) - the battery needs charging.
- CLEAR (or light yellow) - the battery must be replaced. Do not charge the battery or push start the vehicle in this condition.

If the green dot is missing the battery needs charging.

NOTE: *If necessary, clean the battery top to ensure a clear view. Use a flashlight if natural light is poor.*

If the indicator shows clear or yellow, tap the indicator with the handle of a screwdriver to disperse any air bubbles. If the colour is unchanged, the battery must be replaced.

Battery

Battery removal and replacement

WARNING

- **ALWAYS remove the starter key before disconnecting the battery. Failure to do this may cause a failure of the airbag SRS.**
- **Do not reverse the polarity of the battery - the electrical system may be damaged if the battery leads are connected to the wrong terminals.**
- **Keep the battery upright at all times - damage will be caused if the battery is tilted more than 45 degrees.**
- **DO NOT run the engine with the battery disconnected, or disconnect the battery while the engine is running.**

Before disconnecting the battery, disarm the alarm, and ensure that the starter switch and all electrical equipment is turned off.

To remove: disconnect the negative ('-') cable first and then the positive ('+') cable. When reconnecting, connect the positive cable first and then the negative cable. Do not allow the battery terminals to make contact with metal parts of the vehicle.

To release the battery from the vehicle, undo the bolt and remove the battery clamping plate (see illustration).

When replacing, ensure the battery is fitted the right way round (terminal posts towards the rear of the vehicle) and that the clamping plate is secure. Tighten the clamping plate bolt until the clamping plate is free from movement (maximum torque 12 Nm), but do not overtighten.

Battery disposal



Used batteries should be recycled. However, batteries are hazardous - you should seek advice about disposal from a Land Rover Dealer/Authorised Repairer or your local authority.

'Quick release' batteries*

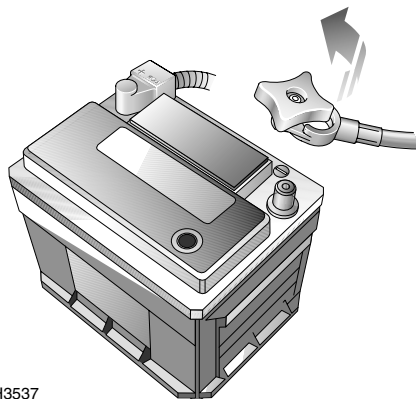

H3537

In some markets, the negative ('-') lead is fitted with a 'quick release' terminal connection. Turn the handwheel anti-clockwise to disconnect the negative lead (as illustrated).

Replacement batteries

Only fit a replacement battery of the same type and specification as the original - other batteries may vary in size or have different terminal positions which could cause a fire hazard when connected to the vehicle's electrical system.

Battery

Battery charging

WARNING

DO NOT charge the battery if it is connected to the vehicle - this may seriously damage the electrical system.

DO NOT attempt to charge the battery if the battery condition indicator is clear or light yellow.

DO NOT charge the battery if it is suspected of being frozen.

As the battery ages, it may not retain its charge as effectively as when it was new. Vehicles that are used infrequently, or are used excessively for short journey motoring, or operation in cold climates, may need the battery to be charged regularly.

Always check the battery condition indicator before charging.

Batteries generate explosive gases, contain corrosive acid and produce levels of electric current sufficient to cause serious injury. While charging, always heed the following precautions:

- Before charging, disconnect and remove the battery from the vehicle.
- Make sure the battery charger leads are securely clamped to the battery terminals BEFORE switching on the battery charger. Do not move the leads once the charger is switched on.
- While charging, shield your eyes, or avoid leaning over the battery.
- Keep the area around the top of the battery well ventilated.
- Do not allow naked lights near the battery (batteries generate inflammable hydrogen during and after charging).

- The battery will be charged sufficiently once the battery condition indicator shows GREEN. When charging is finished, switch off the battery charger BEFORE disconnecting the leads from the battery terminals.

NOTE: *The battery will take longer to charge in a cold environment.*

After charging, leave the battery for one hour before reconnection to the vehicle - this will allow time for explosive gases to disperse, thereby minimising the risk of fire or explosion.

Battery

THE EFFECTS OF BATTERY DISCONNECTION

Some of the vehicle's electrical systems will be affected if the battery is disconnected. These are listed below, together with the symptoms you might experience once the battery is reconnected and the actions required to restore operation.

Radio/cassette player

After battery disconnection, the radio code may be lost and the set fail to operate; this will be apparent from the message appearing in the display. To restore operation, enter the security code using the procedure described in the *'In-car Entertainment'* book.

Taildoor glass

If the battery has been disconnected, the taildoor glass will need to be recalibrated. If the alarm was armed when the battery was disconnected (or discharged), disarm the alarm after battery reconnection - the taildoor glass will fully lower. This will happen automatically if the alarm was in a disarmed state when the battery was disconnected.

After battery reconnection, fully raise the taildoor glass (if the glass is not fully raised, an error 'beep' will sound) - the taildoor glass is now recalibrated.

Alarm system

The alarm system will automatically reset to the status in operation prior to battery disconnection, but the handset will need to be resynchronised (see *'Handset resynchronisation'*, page 34).

Clock

The clock will need to be reset to the correct time, see *'CLOCK'*, page 82.

Tyres

CARING FOR YOUR TYRES

WARNING

DEFECTIVE TYRES ARE DANGEROUS! Do not drive if any tyre is damaged, is excessively worn, or is inflated to an incorrect pressure.

Always drive with consideration for the condition of the tyres, and regularly inspect the tread and side walls for any sign of distortion (bulges), cuts or wear.

The most common causes of tyre failure are:

- Bumping against kerbs
- Driving over deep potholes in the road
- Driving with under or over-inflated tyres

NOTE: *If possible, protect tyres from contamination by oil, grease, fuel and other automotive fluids.*

Tyre pressures

Correctly inflated tyres will ensure that you enjoy the best combination of tyre life, ride comfort, fuel economy and road handling.

Under-inflated tyres wear more rapidly, can seriously affect the vehicle's road handling characteristics and fuel consumption, as well as increasing the risk of tyre failure.

Over-inflated tyres give a harsher ride, wear unevenly and are more prone to damage.

Tyre pressures should be checked at least once a week with normal road use, but should be checked DAILY if the vehicle is used off-road.

Check the pressures (including the spare wheel) when the tyres are cold - be aware that it only takes 1.5 km of driving to warm up the tyres sufficiently to affect the tyre pressures.

NOTE: *The spare tyre pressure on vehicles fitted with steel wheels can be checked through the aperture in the wheel cover (provided the wheel is correctly positioned on the carrier).*

Air pressure naturally increases in warm tyres; if it is necessary to check the tyres when they are warm (after the car has been driven for a while), you should expect the pressures to have increased between 30 - 40 kPa (4 - 6 lbf/in²). In this circumstance, DO NOT let air out of the tyres in order to match the recommended pressures.

WARNING

If the vehicle has been parked in strong sunlight or used in high ambient temperatures, DO NOT reduce tyre pressures; instead, move the vehicle into the shade and allow the tyres to cool before checking.

The recommended pressures for cold tyres are shown in 'TYRE PRESSURES', page 241.

Tyres

Tyre wear



H5086

The tyres fitted as original equipment to your vehicle have wear indicators moulded into the tread pattern. When the tread has worn down to 1.6 mm the indicators start appearing at the surface of the tread pattern, producing the effect of a continuous band of rubber across the width of the tyre.

A tyre **MUST** be replaced as soon as an indicator band becomes visible or the tread depth reaches the minimum permitted by legislation.

NOTE: *If tyre wear is uneven (on one side of the tyre only) or becomes abnormally excessive, the wheel alignment should be checked by your dealer.*

Tread depth must be checked regularly (at every maintenance service, or more frequently). Always replace a tyre before the tread reaches a remaining depth of 1.6 mm. **DO NOT** drive with tyres worn to this limit, the safety of the vehicle and occupants will be adversely affected.

NOTE: *After off-road use, check to make sure there are no lumps or bulges in the tyres or exposure of the ply or cord structure.*

Valves

Keep the valve caps screwed down firmly - they prevent dirt from entering the valve. Check the valve for leaks (listen for a tell-tale hissing) when you check the tyre pressure.

Punctured tyres

Your vehicle is fitted with tubeless tyres, which may not leak if penetrated by a sharp object, provided the object remains in the tyre. If you are aware of this occurring, reduce speed immediately and drive with caution until the spare wheel can be fitted.

A puncture of this kind will eventually cause the tyre to lose pressure, which is why regular (and frequent) checking of tyre pressures is important. Punctured or damaged tyres must be permanently repaired or replaced as soon as possible - if in doubt, seek expert advice.

DO NOT DRIVE WITH A PUNCTURED TYRE!

Tyres

Replacement tyres

Wheel rims and tyres are matched to suit the handling characteristics of the vehicle. For safety, ALWAYS check that replacement tyres comply with the original specification shown in 'WHEELS & TYRES', page 240, and that the load and speed ratings shown on the side wall are the same as that of the original equipment. Contact your Land Rover Dealer/Authorised Repairer for further information or assistance.

Ideally, tyres should be replaced as sets of four, but if this is not possible, replace the tyres as axle sets. When replacing tyres in axle sets, always fit the new tyres to the rear axle.

Always have the wheels and tyres re-balanced after replacing.

WARNING

ALWAYS use the same make and type of radial-ply tyres front and rear. DO NOT use cross-ply tyres, or interchange tyres from front to rear.

Your vehicle is fitted with road wheels that will NOT accept inner tubes. DO NOT fit a tubed tyre.

DO NOT replace wheels with any type other than genuine Land Rover parts. Wheels and tyres are designed for both off-road and on-road use and have a very important influence on vehicle handling. Alternative wheels which do not meet original equipment specifications should not be fitted.

SNOW CHAINS

Snow chains are designed for use on hard surface roads in extreme conditions only, and are not recommended for off-road use. If it is necessary to fit snow chains to your vehicle, ALWAYS observe the following:

- Snow chains can ONLY be fitted to vehicles equipped with 195/80 x 15 tyres.
- It is recommended that ONLY Land Rover approved chains are used - these are designed for your vehicle and will eliminate any risk of damage to other components. Approved snow chains are only available from a Land Rover Dealer/ Authorised Repairer
- Always adhere to the snow chain fitting and retensioning instructions, and the speed limitations recommended for varying road conditions. NEVER exceed 50 km/h.
- ONLY fit snow chains in pairs.
- Avoid tyre damage by removing the chains as soon as the road is free from snow.

For further information about approved snow chains, consult your Land Rover Dealer/ Authorised Repairer.

WARNING

DO NOT fit unapproved snow chains - this could damage tyres, wheels, suspension and brake components and could result in damage to the bodywork of the vehicle.

Cleaning & Vehicle Care

WASHING YOUR VEHICLE



H5215

WARNING

Some high pressure cleaning systems are sufficiently powerful to penetrate door and window seals and damage rubbing strips and locking mechanisms. Never aim the water jet directly at heater air intakes, body and sunroof seals, the softback canopy, or at any components that might easily be damaged.

Read individual product warnings before using any car cleaning or washing products.

If the vehicle is particularly dirty, use a hose to flush grime and grit from the painted surfaces, prior to washing. Then, wash the vehicle using cold or lukewarm water containing a good quality wash and wax shampoo. Always use plenty of water to ensure that grit is flushed from the surface and not ground into the paintwork. After washing, rinse the vehicle with clean water and dry off with a chamois leather.

- Do not use hot water!
- Do not use detergent soap products or washing-up liquid!
- In hot weather, do not wash the vehicle in direct sunlight.

When using a hose, do not direct the jet into the heater air intake ducts, or through the wheel trim apertures onto the brake components, or at the door, window or sunroof seals, or at the soft-back canopy* where water pressure could penetrate the seals.

Automatic car wash

If using an automatic car wash (5-door models), remove the radio aerial before entering the car wash.

NOTE: DO NOT wash a 3-door Softback model in an automatic car wash.

Removing tar spots

Use white spirit to remove tar spots and stubborn grease stains from paintwork. Then wash immediately with soapy water to remove all traces of spirit.

Underbody maintenance

Corrosive materials used for snow and ice removal and dust control can collect on underbody parts. If these materials are not removed, accelerated rusting can occur. Use a hose to regularly flush the underbody with plain water, taking particular care to thoroughly clean those areas where mud and other debris can easily collect.

Similarly, after off-road driving or wading in muddy or salt water conditions, use a hose to wash underbody components and other exposed parts of the vehicle.

Engine compartment

The engine compartment must only be cleaned by steam cleaning.

WARNING

DO NOT use a high pressure hose to clean the engine compartment - damage to the vehicle's electronic systems may occur.

Cleaning & Vehicle Care

Steam cleaning

Before steam cleaning the engine, cover the power steering reservoir to prevent contamination of fluid and ensure the covers and seals of electrical components are in place. After steam cleaning carefully re-wax the metallic components, especially the steering column, engine coolant pipes, hose clips and the ignition coil clamp, to prevent corrosion.

WARNING

Do not direct high temperature or high pressure steam or water onto electrical wiring or components.

Softback canopy and hardback

- Use a soft brush to remove dust and flaking dirt from the canopy or hardback (not the windows), then soak with a mild soap and water solution to soften encrusted dirt and remove stains, prior to washing.
- Wash using a mild soap and water solution, before rinsing the canopy or hardback with clean lukewarm or cold water. Rinse until all traces of soap are removed.
- Never use spirit, petrol or chlorine based cleaning agents, or wash/wax compounds to clean the canopy, hardback and windows - wax polishes will become ingrained in the textured finish.
- Never use an automatic car wash, or a high pressure hose.
- Do not aim jets of water at zips or seals.
- Ensure the canopy is dry before folding or removing.
- Improper cleaning and lack of care may cause damage to the canopy and window panels, resulting in water penetration.

Softback or hardback windows

WARNING

DO NOT use abrasive or solvent cleaners on the canopy or hardback and especially NOT on the window panels. Use only mild detergents.

- Wipe off any dust or dirt using a damp soft cloth.
- DO NOT wipe the window panels when they are dry.
- Wash the windows with a clean, grit-free sponge or cloth and a mixture of a mild dishwashing detergent and cold or lukewarm water. Rinse the window panels thoroughly and wipe with a soft moist cloth.
NOTE: The removable window panels fitted to the softback, are susceptible to scratching from the effects of dirt and grit. For this reason, it is important to wash them frequently.
- Remove frost, ice and snow using lukewarm water - do not use a scraper. Take care when clearing ice or snow from the window panels, as they are easily scratched and could crack at low temperatures.
- Do not put adhesive backed material (badges, stickers etc) onto the window panels - this may result in damage and discolouration.

Body protection

After washing, inspect the paintwork for damage. Any stone chips, fractures or deep scratches in the bodywork should be repaired promptly. Bare metal will corrode quickly and can develop into major repair expense.

Minor chips and scratches can be repaired with touch-up materials available from your dealer. Larger areas of damage need to be corrected to professional standards immediately.

Cleaning & Vehicle Care

Polishing

Occasionally treat the paint surface with an approved polish containing the following properties:

- Very mild abrasives to remove surface contamination without removing or damaging the paint.
- Filling compounds that will fill scratches and reduce their visibility.
- Wax to provide a protective coating between the paint and the elements.

NOTE: *DO NOT* apply wax polish to the Targa roof panels*, or to the bumper mouldings - polish will become ingrained in the textured finished.

Windows and mirrors

Regularly clean all windows and mirrors, inside and out, using an approved glass cleaner.

Windscreen: In particular, clean the outside of the screen with glass cleaner after washing the vehicle with wash and wax products, and before fitting new wiper blades.

Rear screen: Clean the inside with a soft cloth, using a side to side motion to avoid damaging the heating elements. **DO NOT** scrape the glass or use abrasive cleaners - this will damage the heating elements.

Mirrors: Wash with soapy water. Use a plastic scraper to remove ice. **DO NOT** use abrasive cleaners or metal scrapers.

Wiper blades

Wash in warm soapy water. **DO NOT** use spirit or petrol based cleaners.

Cleaning & Vehicle Care

CLEANING THE INTERIOR

WARNING

Read individual product warnings before using any car cleaning or washing products.

| CAR CARE PRODUCTS | |
|--|-----------|
| Fascia Cleaner (300 ml aerosol) | STC4683 |
| Fabric Cleaner (300 ml aerosol) | STC4685 |
| Leather Cleaner (300 ml aerosol) | STC4684 |
| Leather Cleaning Kit* | BAC500490 |
| Insect Remover (300 ml aerosol) | STC4686 |
| Glass Cleaner (300 ml aerosol) | STC4681 |
| Bumper Cleaner (300 ml aerosol) | STC4679 |
| De-icer (300 ml aerosol) | STC4677 |
| De-icer (500 ml trigger spray) | STC4676 |
| Screenwash (250 ml bottle) | STC4672 |
| Screenwash (500 ml bottle) | STC4687 |
| Alloy Wheel Cleaner (500 ml trigger spray) | STC4675 |
| Wash 'n' Wax (300 ml bottle) | STC4680 |
| Wax Polish (300 ml bottle) | STC4682 |

Plastic materials

Clean plastic-faced or cloth covered surfaces with warm water and a non-detergent soap and wipe with a clean cloth.

NOTE: DO NOT polish fascia components - for safety, these should remain non-reflective.

Leather

Leather faced features should be cleaned with a damp cloth moistened with undiluted leather cleaner. Dry and polish the leather with a dry, lint-free cloth.

Land Rover recommends that leather is cleaned and protected at least every six months, but maybe as often as every 1-2 months for high mileage cars or cars kept in a hostile environment.

Leather cleaning kit BAC500490 is recommended and endorsed by Land Rover for this purpose. Use in accordance with the instructions printed on the label.

NOTE: Some materials/fabrics are prone to 'dye-transfer', which can cause unsightly discolouration of lighter colour leathers. Affected areas should be cleaned and re-protected as soon as possible.

DO NOT use chemical or abrasive materials to clean leather. Petrol, white spirit, alcohol, detergents, washing-up liquid, household cleaners, furniture polishes/creams or solvents should never be used on leather. Whilst these products may give initially impressive results, their use will lead to rapid deterioration of the leather and will invalidate the warranty.

Carpet and fabrics

Clean with diluted nylon upholstery cleaner - test a concealed area first.

Cleaning & Vehicle Care

Instrument pack, clock and radio

Use a clean cloth which has been moistened slightly with water.

WARNING

Do not use chemicals or household cleaners. Keep fluids and liquids of all kinds away from the radio.

Fascia mounted rubber mats

The mats are removable for cleaning - replace with care.

Seat belts

Extend the belts, then use warm water and a non-detergent soap to clean. Allow the belts to dry naturally, and do not retract them or use the vehicle until they are completely dry.

WARNING

DO NOT use bleaches, dyes or cleaning solvents on seat belts.

Airbag module covers

To prevent airbag SRS damage, the steering wheel centre pad and other areas containing airbags should ONLY be cleaned sparingly with a damp cloth, warm water and a non-detergent soap.

DO NOT allow these areas to be flooded with liquid, and DO NOT use petrol, detergent, furniture cream or polishes.

Identification Numbers

CONTACTING YOUR DEALER

When communicating with your Dealer/ Authorised Repairer, always quote the Vehicle Identification Number (VIN). If your communication concerns the engine or gearbox, it may be necessary to quote these numbers as well.

IDENTIFICATION NUMBER LOCATIONS

1. Vehicle identification number (VIN)
2. Engine Number

2.0 diesel engine: Stamped horizontally into the flange between the engine casing and gearbox.

1.8 petrol engine: Stamped vertically into the centre front face of the cylinder block.

2.5 petrol engine: Stamped vertically into the right side of the cylinder block (when viewed from the front).

3. Gearbox number

On a label attached to the upper face of the gearbox housing.

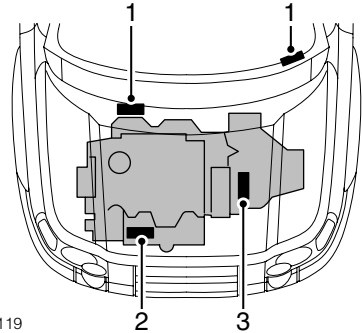

H5119

2.0 Diesel engine

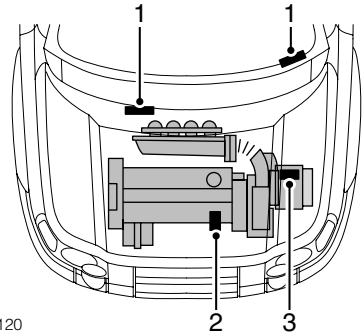

H5120

1.8 Petrol engine

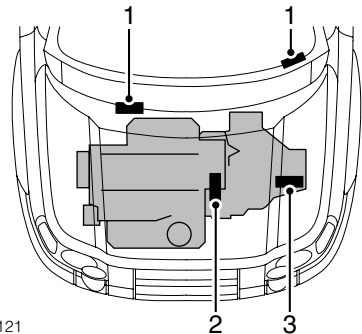

H5121

2.5 Petrol engine

Identification Numbers

VEHICLE IDENTIFICATION NUMBER

The VIN (and recommended maximum vehicle weights) is stamped on a plate at the foot of the left hand door pillar and also stamped into the bulkhead, at the top, inside the engine compartment. In addition, as a deterrent to car thieves and to help the police, the VIN is stamped into a plate, visible at the bottom left hand corner of the windscreen.

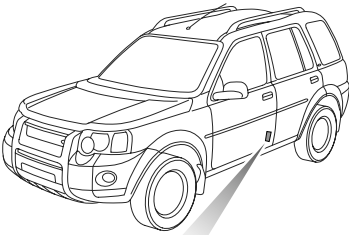

| LAND ROVER | | |
|------------|-----|------------|
| | (A) | |
| | (B) | |
| | (C) | Kg |
| | (D) | Kg |
| 1- | (E) | Kg |
| 2- | (F) | Kg |
| PAINT | | TRIM |
| | | |
| | | LAND-ROVER |

H5122

- A.** Type approval (where required)
- B.** Vehicle Identification Number (VIN)
- C.** Gross vehicle weight (where required)
- D.** Gross train weight (where required)
- E.** Maximum front axle load (where required)
- F.** Maximum rear axle load (where required)

Parts & Accessories

PARTS AND ACCESSORIES

WARNING

The fitting of non-approved parts and accessories, or the carrying out of non-approved alterations or conversions, may be dangerous and could affect the safety of the vehicle and occupants, and also invalidate the terms and conditions of the vehicle warranty.

Your vehicle has been designed, built and tested to cope with a variety of off-road driving conditions, some of which can place the severest possible demands on control systems and components. As such, fitting replacement parts and accessories that have been developed and tested to the same stringent standards as the original components will safeguard the continued reliability, safety and performance of your vehicle.

To augment the vehicle's already impressive performance, a comprehensive range of Land Rover-approved spare parts and accessories is available, enabling the vehicle to fulfil a wide variety of roles, and enhancing and protecting the vehicle in the many tasks to which it can be applied.

Land Rover parts are the only parts built to original equipment specifications AND approved by Land Rover designers; this means that every single part and accessory has been rigorously tested by the same engineering team that designed and built the vehicle and can therefore be guaranteed for twelve months with unlimited mileage.

A full list and description of all accessories is available from your Land Rover Dealer/ Authorised Repairer.

Electrical equipment

It is extremely hazardous to fit parts or accessories where installation requires the dismantling of, or addition to, either the electrical or fuel systems. If an airbag SRS is fitted to your vehicle, it is recommended that you consult a Land Rover dealer before fitting any accessory.

After sales service

The After Sales Parts service is of paramount importance, both in the UK and across the world. In the UK there are over 100 authorised Land Rover dealers, all computer linked to speed the ordering of parts and accessories.

In addition, with worldwide franchised representation in over 100 countries, Land Rover are able to support your vehicle wherever you go.

Land Rover Dealers/Authorised Repairers are able to provide the full range of recommended parts and accessories that meet the rigorous, Land Rover standards of safety, durability and performance.

Travelling abroad

In some countries it is illegal to fit parts that do not conform to the vehicle manufacturer's specification. Owners should ensure that any parts or accessories fitted while travelling abroad, also conform to the legal requirements of their home country.



Emergency Information

Wheel Changing

| | |
|------------------------------|-----|
| TOOL KIT | 201 |
| SPARE WHEEL | 202 |
| LOCKING WHEEL NUTS | 203 |
| JACKING | 204 |
| CHANGING A WHEEL | 206 |

Emergency Starting

| | |
|--|-----|
| STARTING WITH A DISCHARGED BATTERY | 207 |
|--|-----|

Towing The Vehicle

| | |
|--|-----|
| TOWING EYES | 209 |
| TOWING ON 4 WHEELS | 210 |
| TRANSPORTER OR TRAILER LASHING | 210 |

Fuses

| | |
|---------------------------------------|-----|
| FUSES | 211 |
| MAIN FUSE BOX | 211 |
| ENGINE COMPARTMENT FUSE BOX | 215 |
| SUPPLEMENTARY FUSE BOX* | 216 |

Bulb Replacement

| | |
|--|-----|
| REPLACING BULBS | 217 |
| HEADLIGHT - DIPPED BEAM | 218 |
| HEADLIGHT - MAIN BEAM | 219 |
| SIDELIGHTS | 220 |
| FRONT DIRECTION INDICATOR | 221 |
| SIDE REPEATER LIGHT | 222 |
| REAR LIGHT CLUSTER (Reverse & rear fog guard lights) | 222 |
| FRONT FOG LIGHTS | 223 |
| BUMPER MOUNTED LIGHTS (Rear direction indicator & tail/stop lights) | 224 |
| HIGH MOUNTED STOP LIGHT | 225 |
| NUMBER PLATE LIGHTS | 225 |
| FRONT COURTESY & MAP READING LIGHTS (5 door models) | 226 |
| REAR COURTESY LIGHT (5 door models) | 227 |
| COURTESY LIGHT (3 door models) | 227 |
| GLOVEBOX LIGHT | 228 |
| LOADSPACE LIGHT | 228 |
| VANITY MIRROR LIGHT | 229 |





Wheel Changing

TOOL KIT

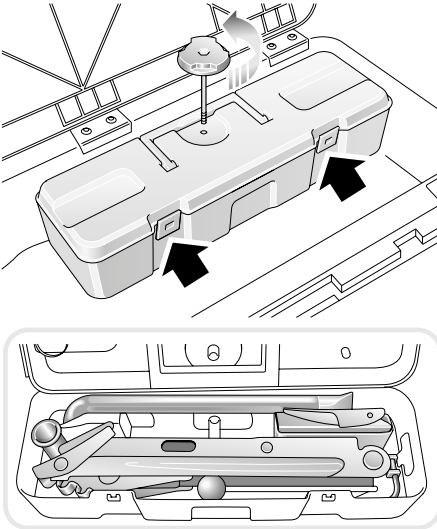

H3492

The tool kit is contained in a toolbox located in the rear loadspace stowage box (see 'STOWAGE BOX', page 146). To remove the toolbox from the stowage box, unscrew the restraining clamp.

To open the toolbox, lift the two catches.

NOTE: When not in use, the tools should always be returned to the toolbox, and the toolbox should be securely clamped in the stowage box.

Only tighten the restraining clamp to 'finger' tightness, when making the toolbox secure.

WARNING

DO NOT drive with the tools or toolbox loose in the vehicle. In the event of a collision they could become dangerous projectiles and cause serious personal injury.

Tools

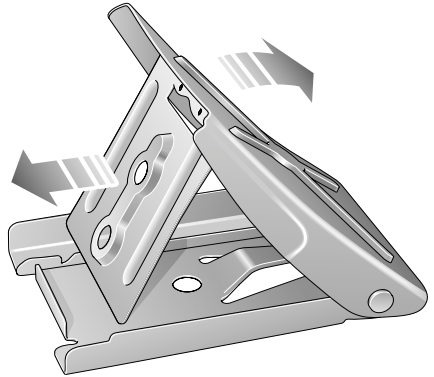

H3497

The tool kit contains the jack, wheel chock, wheel nut spanner and locking wheel nut socket and extractor tool*.

The wheel chock is designed to fold flat and must be assembled, as shown in the illustration, before use.

Care of the jack

Examine the jack occasionally and clean and grease the moving parts.

Always close the jack and return the jack to the toolbox when not in use.

Wheel Changing

SPARE WHEEL

Removing the spare wheel

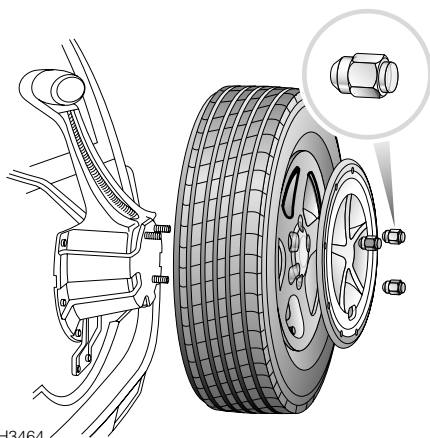

Vehicles fitted with a steel spare wheel are supplied with a cover, which fits against the wheel, and is secured by the wheel nuts.

Use the wheel nut wrench supplied in the tool kit to remove the nuts securing the spare wheel to the carrier and then lift off the wheel.

NOTE: In some markets, vehicles fitted with alloy wheels have a locking wheel nut fitted to each wheel, including the spare (see 'LOCKING WHEEL NUTS', page 203).

For steel wheels, locking wheel nuts are only specified for the spare wheel carrier.

NOTE: Some spare wheels have three stud spacers between the wheel and carrier. Do not remove these if fitted.

WARNING

DO NOT use the spare wheel securing nuts in place of the road wheel nuts, or use the road wheel nuts to secure the spare wheel - the nuts are not inter-changeable.

The wheels are extremely heavy. Take care when lifting and particularly when removing the spare wheel from its mounting position on the tail door.

Temporary use spare wheel

NOTE: In some territories a 195/80 R15 tyre on a steel rim may be supplied for use as a temporary spare wheel. Details are as for a standard wheel and tyre of this size/type, but the rim is both different in colour and carries a warning label.

WARNING

THE FOLLOWING PRECAUTIONS MUST BE OBSERVED WHEN THE TEMPORARY USE SPARE WHEEL (where specified) IS IN USE:

- **DRIVE CAUTIOUSLY.** The temporary use spare wheel is for **TEMPORARY USE** only. It must be replaced by a standard sized wheel and tyre as soon as possible.
- **DO NOT** drive at a speed exceeding 80 km/h (50 mph).
- The tyre pressure in the temporary use spare wheel/tyre should be the same as in the table 'TYRE PRESSURES', page 241.
- It is not permitted to use the vehicle with more than one temporary use spare wheel fitted at the same time.
- Should the temporary use spare tyre require replacement, use one of the same type and specification.

Wheel Changing

Refitting the spare wheel

Position the spare wheel on the carrier.

On vehicles fitted with steel wheels, fit the spare wheel cover. The cover has an aperture at the bottom to allow the tyre pressure of the spare wheel to be checked without removing the cover.

NOTE: For this to be possible, the spare wheel must be placed on its mounting with the valve at the bottom.

Fit and tighten the nuts securing the spare wheel to the carrier.

LOCKING WHEEL NUTS

Vehicles fitted with alloy wheels may be equipped with a locking wheel nut on each wheel (including the spare). The locking wheel nut covers are visually very similar to standard wheel nuts, but can be identified by a concave indent on the surface. The locking wheel nut and cover can only be removed using the special tools provided, as follows:

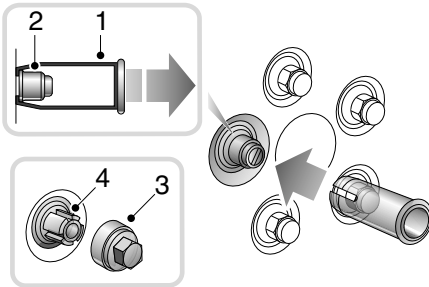

H3465

Push the extractor tool (1) firmly over the stainless steel nut cover (2).

Pull the extractor tool **squarely** away from the wheel to remove the nut cover and reveal the locking wheel nut.

Fit the metal socket (3) over the locking wheel nut (4) then, using the wheel nut wrench, unscrew the nut in the normal way.

NOTE: If the extractor tool has been inadvertently pushed onto a standard wheel nut, it can be removed **ONLY** by first undoing and removing the nut (slide the wheel nut wrench down the centre of the extractor and onto the wheel nut).

NOTE: A code letter is stamped on the face of the key socket. Ensure the code letter is entered in the space provided on your Security Information card - you will need to quote this number if replacement components are required. Keep the card in a safe place away from the vehicle.

Wheel Changing

JACKING

If possible, choose a safe place to stop away from the main thoroughfare. Always ask your passengers to get out of the vehicle and wait in a safe area away from other traffic.

NOTE: Switch on the hazard warning lights to alert other road users.

Before changing a wheel, ensure the front wheels are in the straight ahead position, apply the handbrake and select 1st gear ('P' for automatic transmission).

Turn off the starter switch and remove the key. Observe the following precautions:

- Ensure the jack is positioned on firm, level ground; NEVER on soft ground, or over metal gratings or manhole covers. DO NOT place additional material between the jack and the ground, this may jeopardise the safety of the jacking operation.
- Jacking on a slope is NOT recommended, but if it is unavoidable, chock the wheel diagonally opposite the one to be removed on the downhill side, using the chock provided in the tool kit.
- NEVER jack the vehicle with passengers inside or with a caravan or trailer connected!

WARNING

NEVER work beneath the vehicle with the jack as the only means of support. The jack is designed for wheel changing only!

WARNING

Before raising the vehicle, it is ESSENTIAL to chock the road wheel diagonally opposite the wheel being removed, apply the handbrake and select 1st gear ('P' for automatic transmission).

Wheel Changing

Positioning the jack

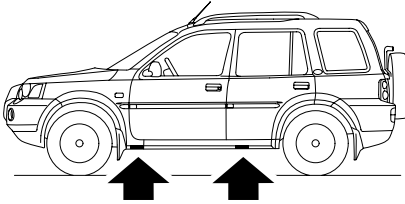

H5154

Use the flat, wedge-shaped end of the wheel nut wrench to lever off the appropriate jacking point cover (1).

Position the jack with the base directly under the jacking point (2) nearest the wheel to be removed and with the handle dropping vertically towards the ground (3). Ensure the jack is positioned on firm, level ground.

Turn the jack screw clockwise to raise the jack until the jack head fits snugly around the centre of the jacking point.

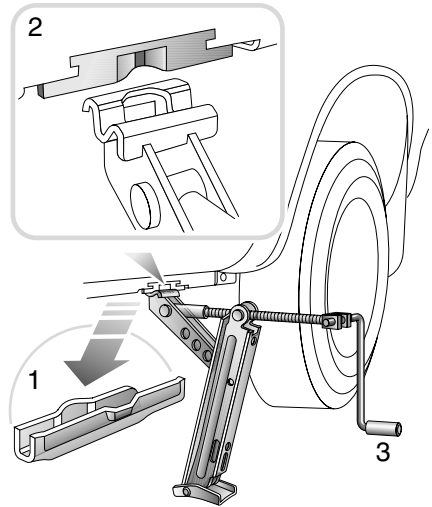

WARNING

ONLY jack the vehicle using the jack location points described, or damage to the vehicle could occur. Under no circumstances should any part of the undertray assembly be used as a jacking point.

Wheel Changing

CHANGING A WHEEL

WARNING

Avoid accidental contact with any underbody parts, especially hot exhaust components.

Removing

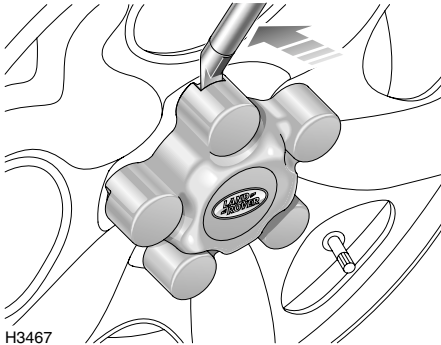

H3467

1. Remove the wheel nut cover* (vehicles with steel wheels) using the flat, wedge-shaped end of the wheel nut wrench.
2. Use the wheel nut wrench to slacken the wheel nuts half a turn anti-clockwise.
3. Turn the jack handle clockwise to raise the vehicle until the tyre is clear of the ground.
4. Remove the wheel nuts and place to one side to prevent them from being lost.
5. Remove the road wheel.

NOTE: Avoid placing wheels face down on the ground. This may scratch the alloy or steel surface.

Refitting

1. On alloy wheels, use an approved anti-seize compound to treat the wheel mounting spigot. This will minimise the tendency for adhesion between wheel and spigot. If this is not practicable to do at the time of wheel change, refit the spare wheel for the time being, but remove and treat the wheel at the earliest opportunity.

WARNING

Ensure that no compound comes into contact with brake components or the flat mounting surfaces of the wheel.

2. Fit the spare wheel and lightly tighten the wheel nuts (domed side towards the wheel) until the wheel is firmly seated against the hub.
3. Ensure that the space under and around the vehicle is free from obstructions, then lower the vehicle and remove the jack.
4. Fully tighten the wheel nuts in an alternating pattern until all are tightened. DO NOT OVERTIGHTEN by using foot pressure or extension bars on the wheel nut wrench, as this could overstress the wheel studs.
5. Refit the jacking point cover.
6. On vehicles with steel wheels, fit the wheel nut cover*.
7. Fit the replaced wheel to the spare wheel carrier (see 'Refitting the spare wheel', page 203).
8. Return the tools to the toolbox and secure the toolbox to its bracket in the lockable stowage box in the rear loadspace.

WARNING

Always check the tyre pressure after changing a wheel, and have the tightness of the wheel nuts checked by a dealer as soon as possible.

Emergency Starting

STARTING WITH A DISCHARGED BATTERY

Using booster cables (jump leads) from a donor battery, or a battery fitted to a donor vehicle, is the only approved method of starting a vehicle with a discharged battery. Push or tow starting is NOT recommended!

However, if the battery is completely discharged (battery condition indicator showing CLEAR), it may not be possible to start the engine using booster cables. In this case a new battery must be fitted.

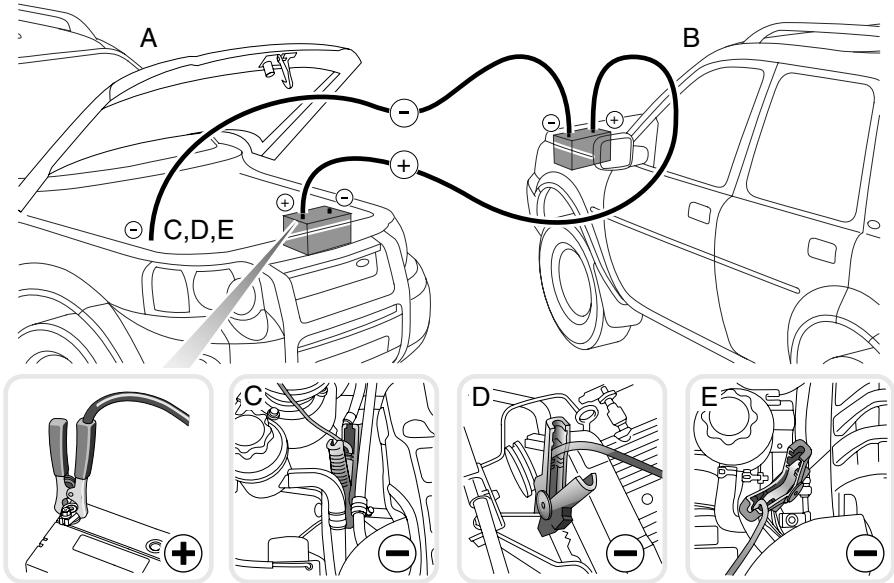

H5155

- A. Disabled vehicle
- B. Donor vehicle
- C. 2.0 Diesel engine earth point
- D. 1.8 Petrol engine earth point
- E. 2.5 Petrol engine earth point

Emergency Starting

WARNING

For safety reasons:

- ***During normal use, batteries emit explosive hydrogen gas sufficient to cause severe explosions capable of causing serious injury - keep sparks and naked lights away from the engine compartment.***
- ***DO NOT attempt to start the vehicle if the electrolyte in the battery is suspected of being frozen.***
- ***Make sure BOTH batteries are of the same voltage (12 volts), and that the booster cables have insulated clamps and are approved for use with 12 volt batteries.***
- ***DO NOT disconnect the discharged battery.***
- ***DO NOT connect positive (+) terminals to negative (-) terminals, and ensure booster cables are kept away from any moving parts in the engine compartment.***
- ***Take care when working near rotating parts of the engine.***
- ***ENSURE that each connection is securely made and that there is no risk of the clips accidentally slipping or being pulled from the battery terminals - this could cause sparking, which could lead to fire or explosion.***

Always adopt the following procedure:

If a donor vehicle is to be used, both vehicles should be parked with their battery locations adjacent to each other. Ensure that the two vehicles do not touch.

Apply the handbrakes and ensure that the transmission of both vehicles is set in neutral ('P' or Park for vehicles with automatic transmission).

Turn off the starter switch and ALL electrical equipment of BOTH vehicles.

Connect the RED booster cable between the positive (+) terminal of the donor battery and the positive (+) terminal of the discharged battery.

Connect the BLACK booster cable from the negative (-) terminal of the donor battery to a good earth point (eg. an engine mounting or other unpainted surface) at least 0.5m from the battery and well away from fuel and brake lines on the disabled vehicle (refer to insets 'C', 'D' and 'E' on the previous page).

WARNING

DO NOT connect a booster cable to the negative (-) terminal of the discharged battery! If in doubt, seek qualified assistance.

Check that the cables are clear of any moving parts of both engines, then start the engine of the donor vehicle and allow it to idle for a few minutes.

Now start the vehicle with the discharged battery (DO NOT crank the engine for more than 15 seconds).

Once both engines are running normally, allow them to idle for two minutes before switching off the engine of the donor vehicle. DO NOT switch on any electrical circuits on the previously disabled vehicle until AFTER the booster cables have been removed.

Disconnecting the booster cables must be an EXACT reversal of the procedure used to connect them, ie: disconnect the BLACK cable from the earth point on the disabled vehicle FIRST.

Towing The Vehicle

TOWING EYES

WARNING

The towing eyes at the front and rear of the vehicle are designed for vehicle recovery purposes only and must NOT be used to tow a trailer or caravan. Excessive force should not be used when being recovered, or when recovering other vehicles using the towing eyes.

Front

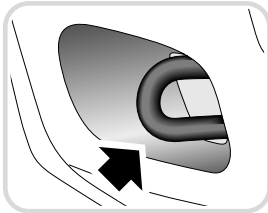
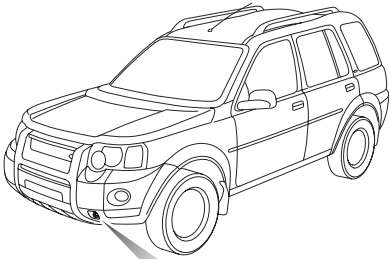

H5149

A single towing eye, set in the front spoiler is provided for use **ONLY** when the vehicle is to be towed with all four wheels on the ground.

DO NOT use the front lashing ring for towing purposes.

Rear

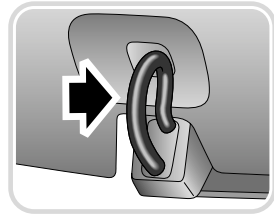
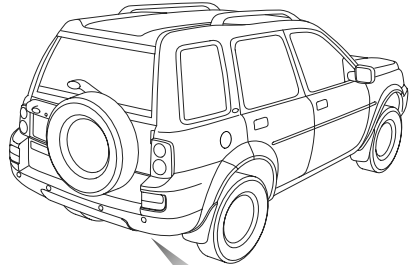

H5150

A single towing eye is provided at the rear of the vehicle for use **ONLY** when towing another vehicle.

Towing The Vehicle

TOWING ON 4 WHEELS

Most vehicle recovery specialists will load your vehicle onto a trailer. However, if it is necessary to recover the vehicle by towing with all four wheels on the ground, observe the following procedure:

1. Secure the towing attachment from the recovery vehicle to the front towing eye of the vehicle to be recovered.
2. With the handbrake applied, place the gear lever in neutral ('N' Neutral for automatic transmission).
3. Turn the starter switch to position 'I' to unlock the steering, and then to position 'II' to enable the brake lights, wipers and direction indicators to be operated, if necessary.
4. Release the handbrake.

NOTE: If, due to an accident or electrical fault, it is not considered safe to turn the starter switch, the battery should first be disconnected. Brake lights and indicators will not operate.

WARNING

DO NOT turn the starter switch to position '0', or remove the key, while the vehicle is in motion; the starter switch must be at position 'I' to unlock the steering.

Without the engine running, the brake servo and power steering pump cannot provide assistance; greater effort will therefore be required to operate the brake pedal and turn the steering wheel. Longer stopping distances will also be experienced.

DO NOT allow the vehicle to be towed further than 80 km and restrict towing speed to 50 km/h.

Suspended tow

If it is necessary to tow your vehicle on two wheels (ie: suspended from a recovery vehicle), it is essential that the propeller shaft connected to the axle that is to remain on the ground is disconnected by qualified personnel, prior to being towed.

TRANSPORTER OR TRAILER LASHING

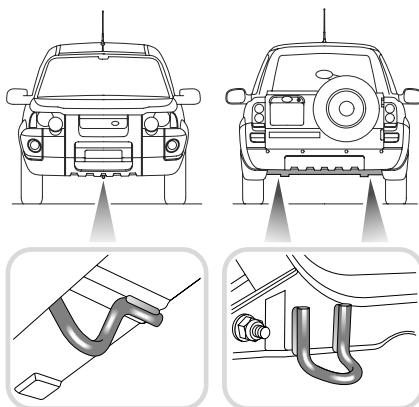

H5151

Lashing rings are fixed to the underside of the vehicle, where shown in the illustration.

Under no circumstances should the vehicle be towed or recovered by lashing to the rear subframes. Serious damage to the subframe and body may occur.

WARNING

The lashing rings are for lashing only and must NOT be used for towing.

Fuses

FUSES

Fuses are simple circuit devices which protect electrical equipment against the effects of excess current.

A 'blown' fuse is indicated when the electrical equipment it protects becomes inoperative.

Fuse colours

Fuses are colour coded to help identify their amperage, as follows:

| | |
|--------|---------|
| VIOLET | 3 amp |
| TAN | 5 amp |
| BROWN | 7.5 amp |
| RED | 10 amp |
| BLUE | 15 amp |
| YELLOW | 20 amp |
| WHITE | 25 amp |
| GREEN | 30 amp |
| ORANGE | 40 amp |

MAIN FUSE BOX

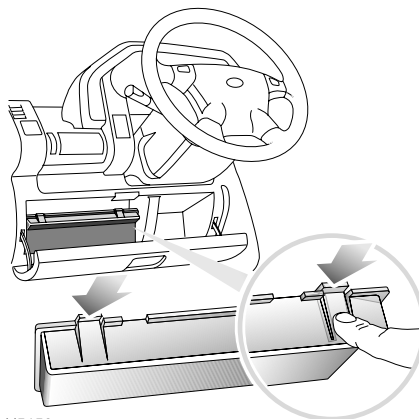

H5152

The main fusebox is located behind the driver's storage area. To access the fuses, open the storage area, depress the two catches arrowed in the illustration and remove the fuse box cover.

NOTE: A label in the fuse box cover shows the electrical circuits protected, the fuse values and their locations. They are also listed later in this section.

Checking or renewing a fuse

Always turn the starter switch to position '0' and switch off the affected electrical circuit before removing a fuse.

WARNING

To prevent a possible fire or damage to the electrical system, only fit replacement fuses of the same rating and type. Do not replace a blown fuse with a fuse of a higher amperage rating. Always rectify the cause of the failure before replacing a fuse. Seek qualified assistance if necessary.

Fuses

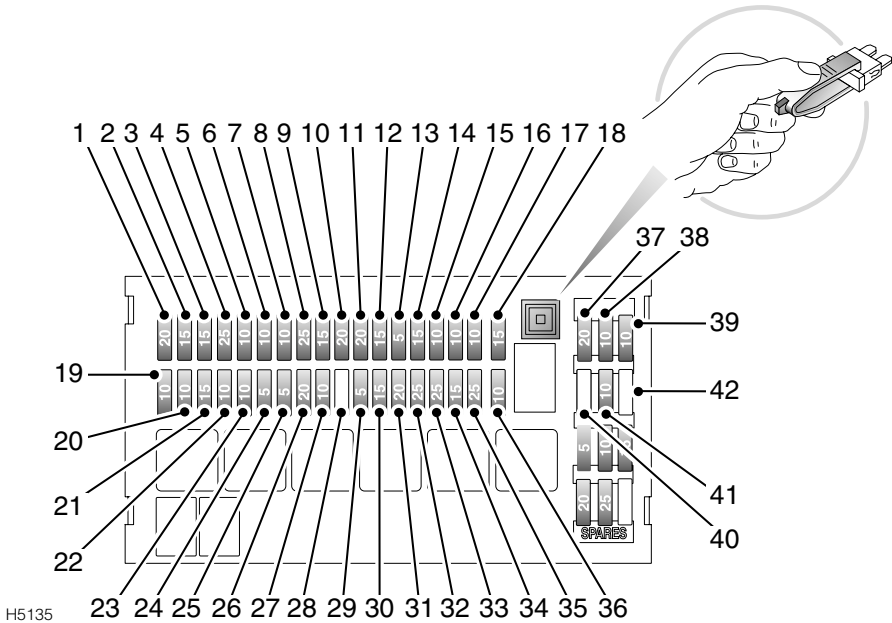

Press the fuse removal tweezers onto the head of the suspect fuse (as shown) and pull to remove. A break in the wire inside the fuse indicates that the fuse has 'blown' and must be replaced.

Always replace a fuse with another of the same value. However, if the replacement fuse blows immediately, the circuit **MUST** be checked by a qualified dealer.

NOTE: A number of spare fuses are included inside the fuse box (see fuse box label).

Fuses

Fuse specification

| Fuse number | Rating (amps) | Circuits protected |
|-------------|---------------|--|
| 1 | 20 | Front screen wash/wipe |
| 2 | 15 | Stop lights, reversing lights |
| 3 | 15 | Heated mirrors/Rear screen wash |
| 4 | 25 | Heater blower |
| 5 | 10 | Starter motor |
| 6 | 10 | Cruise control*/HDC/Automatic Gearbox start inhibit. |
| 7 | 10 | Side lamps - LH |
| 8 | 25 | Driver's front window lift |
| 9 | 15 | Cigar lighter |
| 10 | 20 | Electric accessories socket |
| 11 | 20 | Heated seats |
| 12 | 15 | Audio system - Vehicle battery power feed |
| 13 | 5 | Engine immobilisation |
| 14 | 15 | Headlight main beam - RH |
| 15 | 10 | Door mirrors |
| 16 | 10 | Interior lights/Clock |
| 17 | 10 | Side lamps - RH |
| 18 | 15 | Instruments/Indicators |
| 19 | 10 | Headlight dipped beam - RH |
| 20 | 10 | Headlight dipped beam - LH |
| 21 | 15 | Sunroof* |
| 22 | 10 | Engine management |
| 23 | 10 | Airbag |
| 24 | 5 | Parking aid |
| 25 | 5 | Anti-lock brakes |
| 26 | 20 | Heated rear window |
| 27 | 10 | Audio system |
| 28 | | Not used |
| 29 | 5 | Electric windows |
| 30 | 15 | Front fog lights |
| 31 | 20 | Taildoor glass lift/drop |
| 32 | 25 | Rear window lift - LH |
| 33 | 25 | Rear window lift - RH |
| 34 | 15 | Headlight main beam - LH |
| 35 | 25 | Passenger front window lift |
| 36 | 10 | Rear fog lights |
| 37 | 20 | Central door locking |

Fuses

| Fuse number | Rating (amps) | Circuits protected |
|-------------|---------------|-----------------------|
| 38 | 10 | Rear wiper |
| 39 | 10 | Front fog lamp switch |
| 40 | | Not used |
| 41 | 10 | Alternator |
| 42 | | Not used |

Fuses

ENGINE COMPARTMENT FUSE BOX

WARNING

Batteries emit explosive hydrogen gas; ensure that sparks, flames and other ignition sources are kept away from the engine compartment.

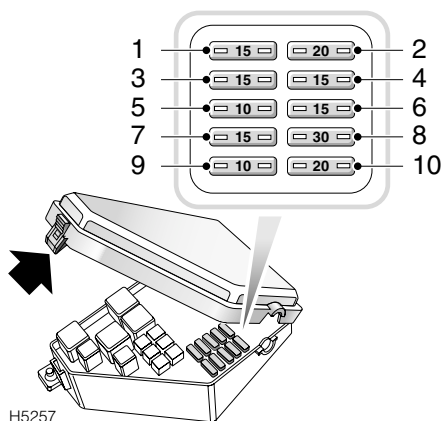

H5257

Press the catch (arrowed in illustration) to release the cover.

Information on the underside of the cover identifies the fuses and their ratings. This information is also listed below.

NOTE: Owners are advised against removing or replacing the fusible links and relays, identified on the underside of the fuse box lid as: FL (numbers 1 - 12) and R (numbers 1 - 7). Failure of any of these items should be investigated by a qualified technician.

The engine compartment fuse box is located on the left side of the engine compartment.

Fuse specification

| Fuse number | Rating (amps) | Circuit protected |
|-------------|---------------|---|
| 1 | 15 | Engine management |
| 2 | 20 | Engine management |
| 3 | 15 | Engine management |
| 4 | 15 | Air conditioning*, cooling fan, automatic gearbox |
| 5 | 20 | Engine management, transmission cooling fan* fuel burning heater* |
| 6 | 15 | Horn |
| 7 | 15 | Hazard warning lights |
| 8 | 30 | Heater blower speed 4 |
| 9 | 10 | Air conditioning* |
| 10 | 20 | Fuel system |

Fuses

SUPPLEMENTARY FUSE BOX*

WARNING

Batteries emit explosive hydrogen gas; ensure that sparks, flames and other ignition sources are kept away from the engine compartment.

An additional, supplementary fuse box is fitted to some vehicles, containing fuses for either the heated front screen, or the PTC system heater.

Fuse specification for vehicles with a heated front screen

| Fuse number | Rating (amps) | Circuit protected |
|-------------|---------------|------------------------|
| 1 | 30 | LH heated front screen |
| 2 | 30 | RH heated front screen |
| 3 | 7.5 | Switch illumination |
| 4 | - | - |

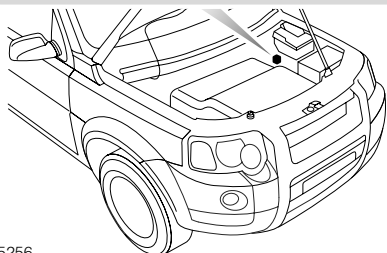
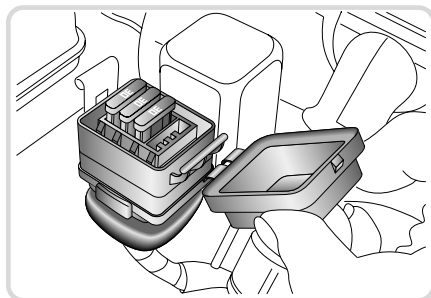

H5256

Fuse specification for vehicles with a PTC system heater

| Fuse number | Rating (amps) | Circuit protected |
|-------------|---------------|-------------------|
| 1 | 30 | PTC heater |
| 2 | 30 | PTC heater |
| 3 | 30 | PTC heater |
| 4 | - | - |

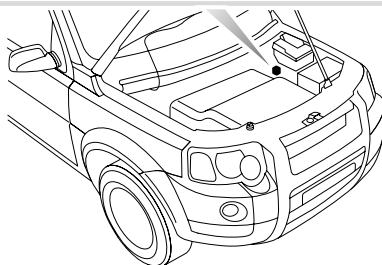
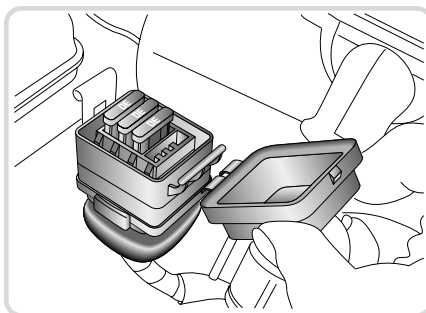

H5228

Bulb Replacement

REPLACING BULBS

Check the operation of all exterior lights before you use the vehicle.

IMPORTANT

Before replacing a bulb, always switch off the starter switch and appropriate lighting switch to prevent any possibility of a short circuit. Only replace bulbs with the same type and specification.

Halogen bulbs

Halogen bulbs are used for headlight dipped and main beams. This type of bulb may shatter in use if the glass has been scratched, or contaminated with oil or perspiration. Take care NOT to touch the glass with your fingers; always use a cloth to handle the bulb. If necessary, clean the glass with methylated spirits to remove fingerprints.

Replacement bulbs

NOTE: All bulbs must be rated at 12 volts

| Bulb | Watts |
|--------------------------|--------|
| Headlights dipped beam | 55 H7 |
| Headlights main beam | 55 H7 |
| Side lights | 5 |
| Direction indicators | 21 |
| Front fog lights | 55 H11 |
| Side repeater lights | 5 |
| Reverse lights | 21 |
| Rear fog guard lights | 21 |
| Tail/Stop lights | 5/21 |
| High mounted stop light | 21 |
| Number plate light | 5 |
| Interior courtesy lights | 10 |
| Map reading lights | 5 |
| Glovebox light | 5 |
| Loadspace light | 10 |
| Vanity mirror light | 3 |

NOTE: In certain territories it is a legal requirement to carry spare bulbs, in case of bulb failure. A replacement bulb kit is available as an approved accessory from your Land Rover Dealer/Authorised Repairer.

Bulb Replacement

HEADLIGHT - DIPPED BEAM

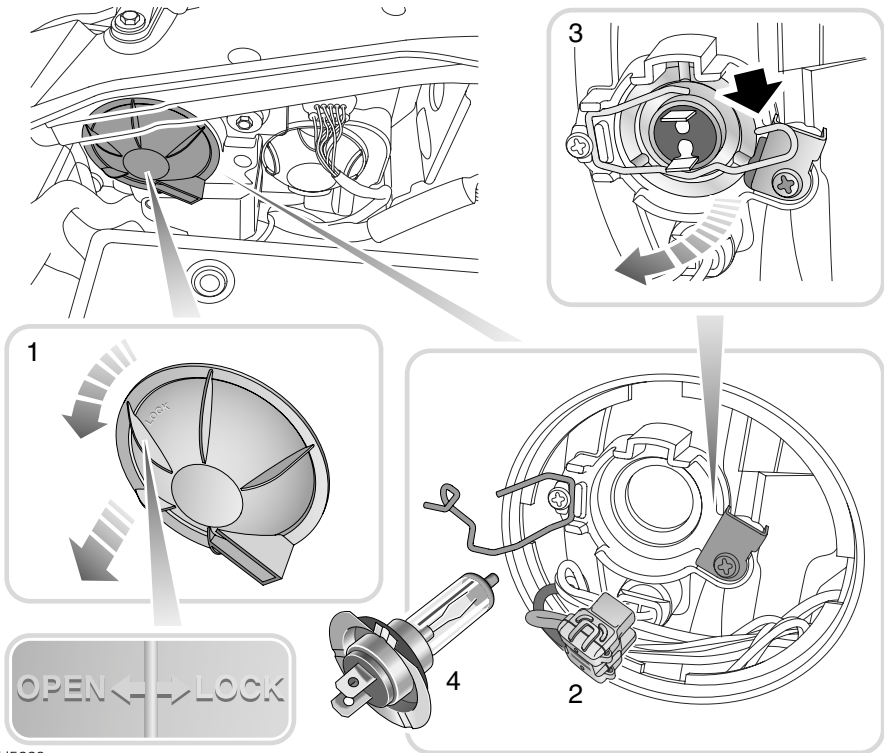

H5220

The headlight dipped beam bulb can be accessed from within the engine compartment.

1. Turn the circular plastic cover a quarter turn anti-clockwise (open) and pull rearwards to remove.
2. Detach the electrical connector from the rear of the bulb.
3. Unhook the wire securing clip (arrowed in small inset) and pivot it away from the rear of the bulb.
4. Remove the bulb.

NOTE: When fitting the new bulb, ensure that the metal tab is located in the upper recess.

WARNING

During use, headlight bulbs may shatter if the glass has been scratched, or contaminated with oil or perspiration. DO NOT touch the glass. If handled, clean with methylated spirits and a clean cloth.

Bulb Replacement

HEADLIGHT - MAIN BEAM

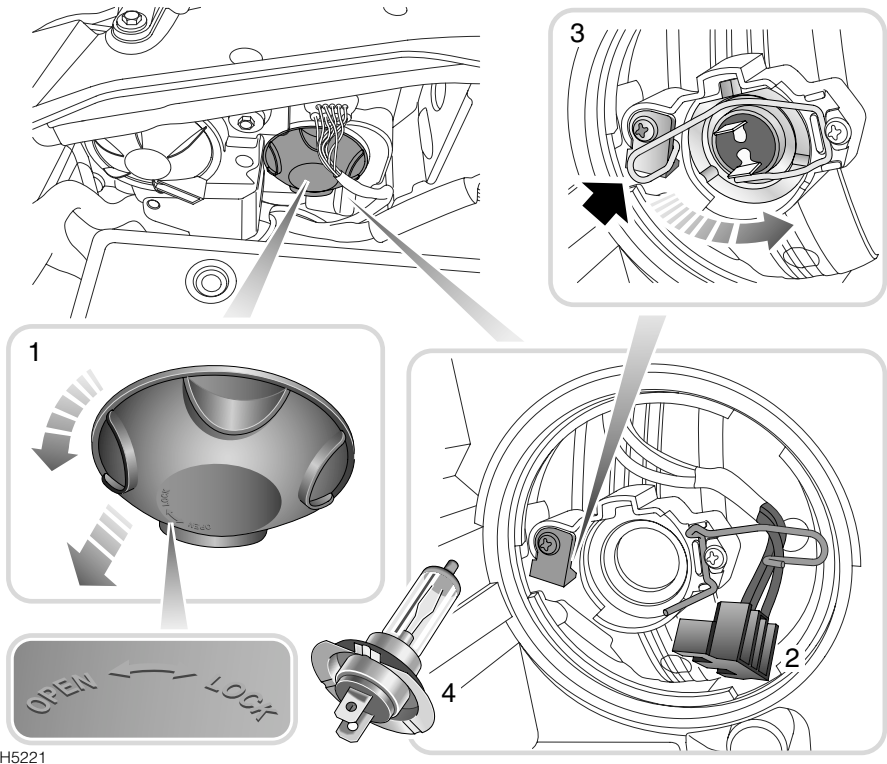

The headlight main beam bulb can be accessed from within the engine compartment.

1. Turn the circular plastic cover a quarter turn anti-clockwise (open) and pull rearwards to remove.
2. Detach the electrical connector from the rear of the bulb.
3. Unhook the wire securing clip (arrowed in small inset) and pivot it away from the rear of the bulb.
4. Remove the bulb.

NOTE: When fitting the new bulb, ensure that the metal tab is located in the upper recess.

WARNING

During use, headlight bulbs may shatter if the glass has been scratched, or contaminated with oil or perspiration. DO NOT touch the glass. If handled, clean with methylated spirits and a clean cloth.

Bulb Replacement

SIDELIGHTS

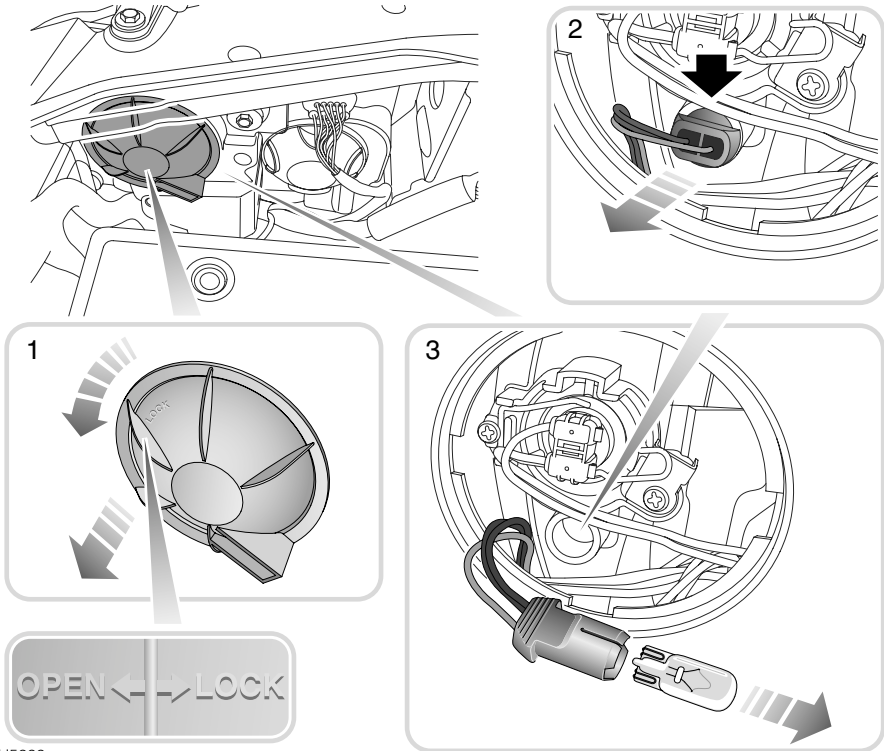

H5222

The sidelight bulb can be accessed from within the engine compartment.

1. Turn the circular plastic cover (Dipped beam) a quarter turn anti-clockwise (open) and pull rearwards to remove.
2. Pull sidelight bulb holder from the headlight unit.
3. Pull bulb out of bulb holder.

Bulb Replacement

FRONT DIRECTION INDICATOR

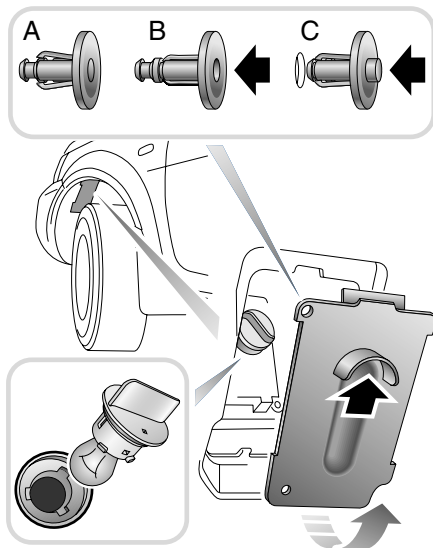

H5242

When replacing the access panel, insert the top first, then lower the panel slightly so that the bottom edge slots securely onto the wheel arch liner.

To replace the fastener, push the centre pin out of the fixing (as condition 'C'), then locate the fastener through the access panel and into the wheelarch liner. Finally, push the centre pin into the fastener until it lies flush with its body as condition 'A'.

The front direction indicator lights are reached through an access panel in the wheel arch liner. To release the panel, first remove the fixing shown in the upper inset.

1. Push the centre pin of the fastener 'A' in upper inset, firmly into its body (as condition 'B').
2. Prise the fastener from the access panel.
3. Holding the curved tab, push the access panel upwards (as arrowed in main illustration). This will enable the panel to be removed.
4. Reach into the recess and twist the bulb holder anti-clockwise to remove.
5. Twist the bulb anti-clockwise to release it from the bulb holder.

Bulb Replacement

SIDE REPEATER LIGHT

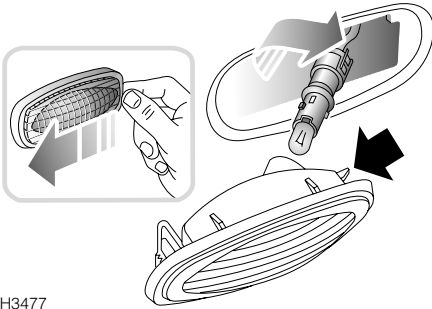

H3477

Push the lens firmly towards the rear of the vehicle and withdraw the light unit from the wing.

Twist to release the bulb holder from the light unit, then pull the bulb from its socket.

When refitting the light unit, ensure that the little tabs (arrowed in illustration) are pointing towards the front of the vehicle.

REAR LIGHT CLUSTER (Reverse & rear fog guard lights)

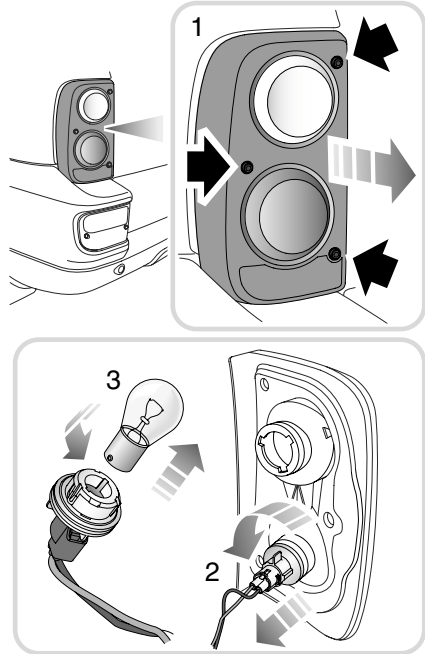

H5227

1. Remove the three Torx (size 20) screws securing the light unit to the body and withdraw the light unit.
Disconnect the electrical connectors from the light unit if necessary.
2. Twist the bulb holder anti-clockwise and pull to release from the light unit.
3. Twist the bulb anti-clockwise and pull to remove from the holder.

NOTE: When refitting the light unit, ensure that the foam seal is correctly positioned between the light unit and body.

Bulb Replacement

FRONT FOG LIGHTS

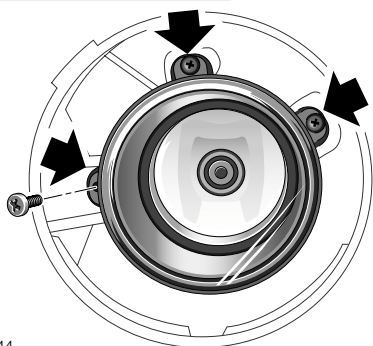
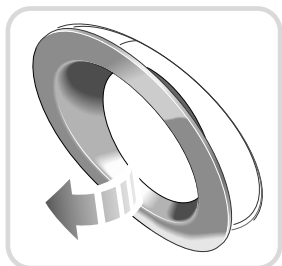

H5144

To access the bulb; using a suitable tool, lever the fog light surround panel out of the front bumper. Remove the three securing screws to release the light unit. Ease the unit out of the front bumper.

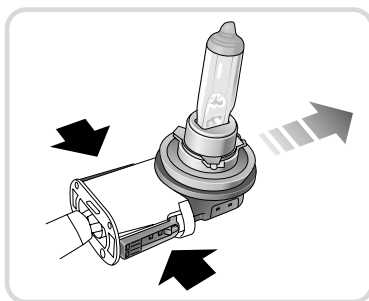
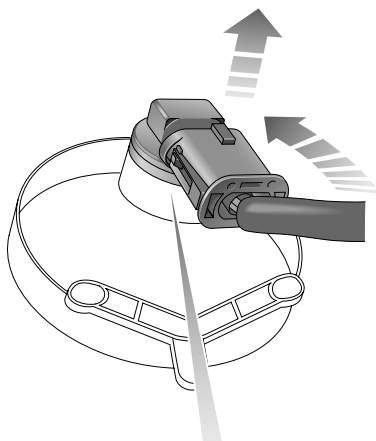

H5145

To remove the bulb from the light unit, twist and pull, press in the two lock tabs on the electrical connector to release the bulb. Fit a new bulb to the connector and re-fit into the fog light unit.

NOTE: Do not touch the bulb glass with your fingers. If necessary, clean the bulb with methylated spirits.

Bulb Replacement

BUMPER MOUNTED LIGHTS

(Rear direction indicator & tail/stop lights)

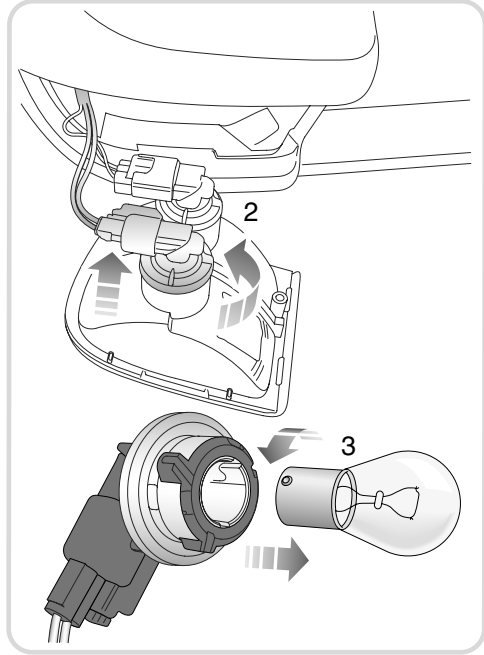
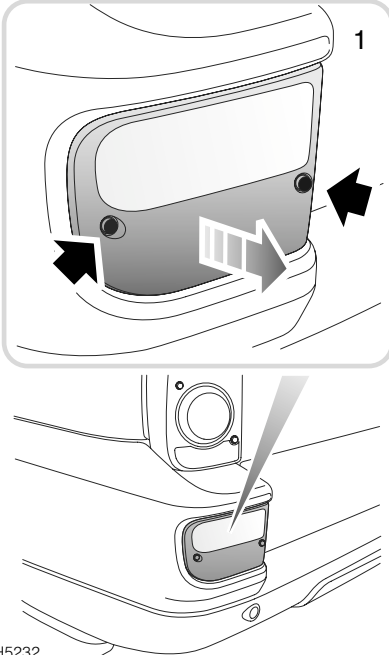

H5232

1. Remove the two Torx (size 20) screws securing the light unit to the bumper. Withdraw the light unit from the bumper. Disconnect the electrical connectors from the light unit if necessary.
2. Twist the appropriate bulb holder anti-clockwise and pull to release from the light unit. (The indicator is located above the tail/stop light).
NOTE: The bulb holders are colour coded to facilitate correct reconnection, white for tail/stop lights and orange for the rear direction indicator lights.
3. Twist the bulb anti-clockwise and pull to remove from the holder.

Bulb Replacement

HIGH MOUNTED STOP LIGHT

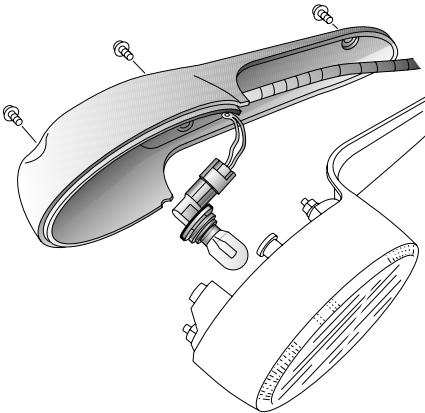

H2358A

To gain access to the light unit, the taildoor glass needs to be lowered (see *'ELECTRIC TAILDOOR GLASS'*, page 71).

Remove the 3 screws securing the front of the light unit to the surround and withdraw the light unit.

Twist the bulb holder anti-clockwise, then pull the bulb to remove.

NUMBER PLATE LIGHTS

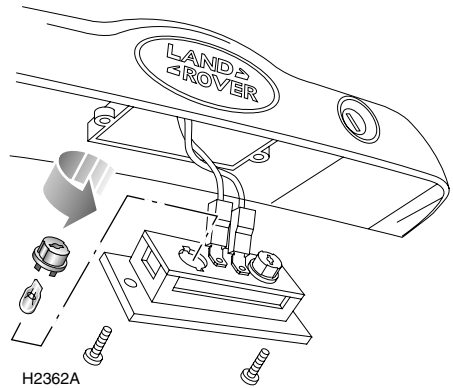

Remove both screws to release the light unit. Withdraw the light unit from its surround.

Twist the appropriate bulb holder anti-clockwise to release, then pull the bulb from the holder to remove.

Bulb Replacement

FRONT COURTESY & MAP READING LIGHTS (5 door models)

Front courtesy light

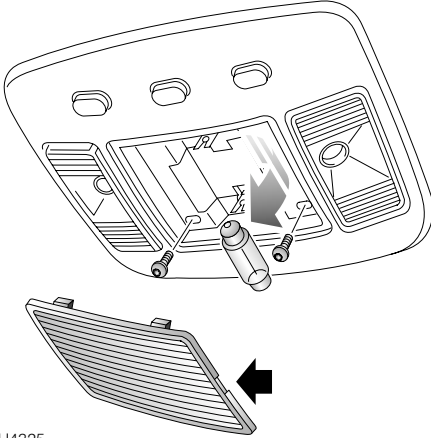

H4325

Insert a small, flat-bladed screwdriver into the indent on one side of the centre lens (arrowed in illustration). Prise the centre lens from the light unit, then pull the bulb from the clips.

Map reading lights

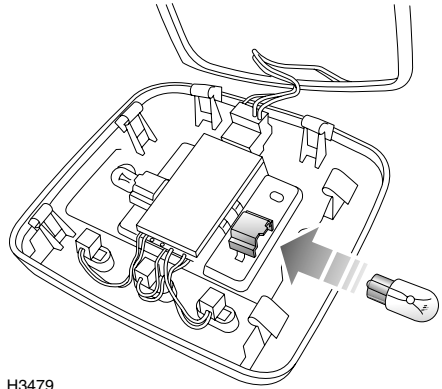

H3479

Remove the centre lens (as described on previous page) to reveal two Torx screws.

Remove both screws.

Use a larger flat-bladed screwdriver to prise the courtesy light unit from the headlining, then pull the bulbs to remove.

Bulb Replacement

REAR COURTESY LIGHT (5 door models)

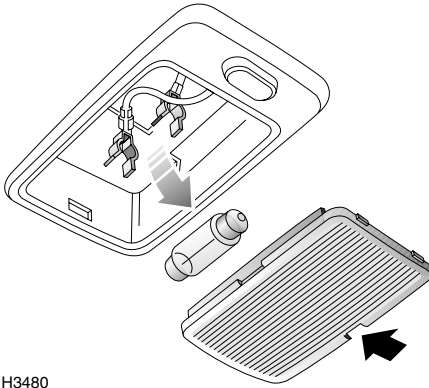

H3480

Insert a small flat-bladed screwdriver into the indent on the side of the lens and prise the lens from the light unit, then pull the bulb from the clips.

COURTESY LIGHT (3 door models)

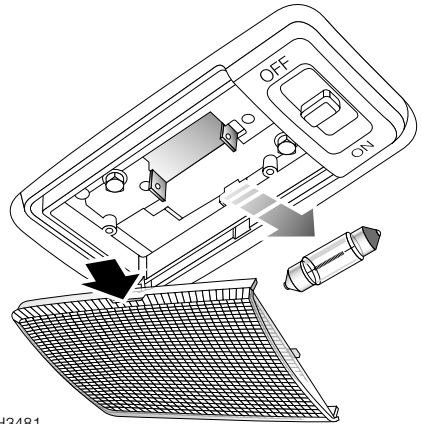

H3481

Insert a small flat-bladed screwdriver where arrowed and carefully prise the lens from the light unit, then pull the bulb to remove.

Bulb Replacement

GLOVEBOX LIGHT

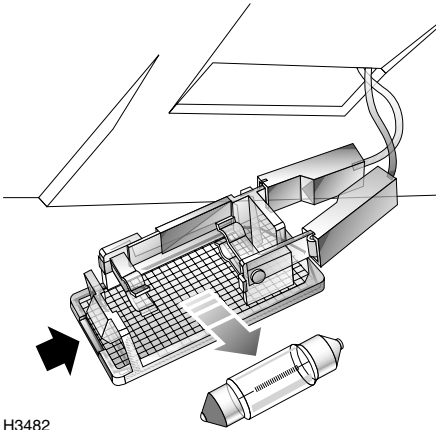

H3482

Insert a small flat-bladed screwdriver (preferably with a short handle, due to limited access) into the indent (arrowed in illustration) on the narrow side of the light unit, and carefully prise the unit from the glovebox panel. Remove the bulb from the clips.

LOADSPACE LIGHT

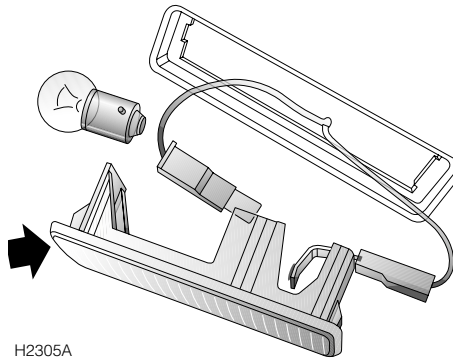

H2305A

Insert a small flat-bladed screwdriver into the indent on one of the narrow sides of the lens (see arrow on illustration) and carefully prise the unit from the loadspace trim panel. Push and twist the bulb to remove.

Bulb Replacement

VANITY MIRROR LIGHT*

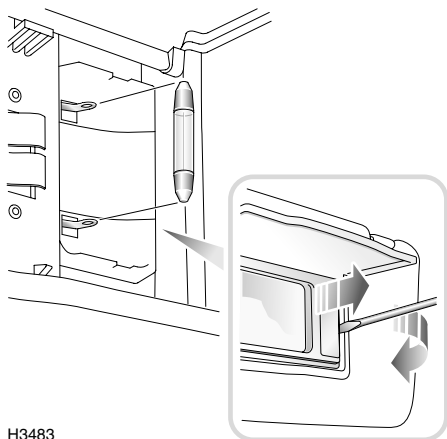

H3483

Using a small, flat-bladed screwdriver as a lever (see inset), prise the lens and mirror from the light unit. 'Spring' the bulbs free from the connectors to remove.



Technical Data

Lubricants & Fluids

LUBRICANTS AND FLUIDS 233

Capacities

CAPACITIES 235

Engines

ENGINES 236

Electrical System

ELECTRICAL SYSTEM 238

Steering

STEERING 239

Wheels & Tyres

WHEELS & TYRES 240

Tyre Pressures

TYRE PRESSURES 241

Dimensions

DIMENSIONS - 3 & 5 DOOR 242

Dimensions

DIMENSIONS - 'SPORT' 3 & 5 DOOR 243

Tow Bar Dimensions

TOW BAR DIMENSIONS 244

Vehicle Weights

VEHICLE WEIGHTS 245

Towing Weights

TOWING WEIGHTS 246

Fuel Consumption

FUEL CONSUMPTION 247

Appendices

DECLARATIONS OF CONFORMITY 248



**LAND ROVER
RECOMMENDS**



Lubricants & Fluids

LUBRICANTS AND FLUIDS

Recommendations for all climates and conditions.

NOTE: *Recommended oils are complete in themselves and additives should not be used.*

NOTE: *It is essential to change oil much more frequently if the vehicle is operated under severe conditions, especially if deep wading is carried out.*

Engine oil - Petrol vehicles - 1.8 litre & 2.5 litre - V6

Use a 10W/40 oil meeting specification ACEA: A2 or A3 and having a viscosity band recommended for the temperature range of your locality.

Engine oil - Diesel vehicles

Use a 0W/30, 5W/30, 5W/40, 5W/50, 10W/30, 10W/40 or 10W/60 oil meeting specification ACEA: A3 and B3, and having a viscosity band recommended for the temperature range of your locality.

Engine oil temperature ranges

0W/30 will protect from -30°C to 35°C.

5W/30 will protect from -30°C to 35°C .

5W/40 will protect from -30°C to 50°C.

5W/50 will protect from -30°C to 50°C.

10W/30 will protect from -10°C to 30°C.

10W/40 will protect from -10°C to 50°C.

10W/60 will protect from -10°C to 50°C.

Manual gearbox

Use Texaco MTF 94 oil.

Automatic gearbox

Use Texaco ATF N402 or Unipart ATF JF 403E oil.

Intermediate Reduction Drive

API GL5 + MT1

Rear Differential

API GL5.

Power steering

Use ATF Dextron III.

Lubricants & Fluids

Brake reservoir

Shell ESL Donax EB brake fluid or any brake fluid having a minimum boiling point of 260°C and complying with FMVSS 116 DOT4.

Windscreen washers

Screen washer fluid.

Engine cooling system

Use Castrol Anti-freeze SF or Texaco XLC. Use one part anti-freeze to one part water for protection down to -36° C.

Inertia reel seat belts

DO NOT LUBRICATE. These components are lubricated for life during manufacture.

Capacities

CAPACITIES

| | |
|---------------------------------|------------|
| Fuel tank (usable): | |
| Petrol engines | 64 litres |
| Diesel engines | 59 litres |
| | |
| Engine oil (and filter) refill: | |
| 1.8 Petrol engines | 4.5 litre |
| 2.5 Petrol engines | 5.2 litre |
| 2.0 Diesel engines | 6.8 litre |
| | |
| Manual gearbox fill from dry: | |
| 1.8 Petrol engines | 2.2 litre |
| 2.0 Diesel engines | 1.6 litre |
| Automatic gearbox refill: | |
| 2.5 Petrol engines | 4.0 litre |
| 2.0 Diesel engines | 4.0 litre |
| | |
| Cooling system fill from dry: | |
| 1.8 Petrol engines | 5.8 litre |
| 2.5 Petrol engines | 7.8 litre |
| 2.0 Diesel engines: | |
| - Manual transmission | 7.25 litre |
| - Automatic transmission | 7.5 litre |
| | |
| Washer reservoir | 4.0 litres |

Engines

ENGINES

1.8 litre petrol

| | |
|--|---|
| Fuel | UNLEADED 95 RON† to EN 228 specification is recommended |
| Capacity | 1796 cm ³ |
| Firing order | 1-3-4-2 |
| Idle speed | 750 ± 50 rev/min |
| Bore | 80 mm |
| Stroke | 89.3 mm |
| Number of cylinders | 4 in-line |
| Compression ratio | 10.5:1 |
| Ignition system | MEMS3 breakerless, electronic |
| Spark plugs | GSP 66527 |
| Spark plug gap | 1.0 mm ± 0.05 |
| CO ₂ emissions | 248 g/km |
| † Unleaded fuels of 95 - 98 RON can be used. | |

2.5 litre petrol

| | |
|--|---|
| Fuel | UNLEADED 95 RON† to EN 228 specification is recommended |
| Capacity | 2497 cm ³ |
| Firing order | 1-6-5-4-3-2 |
| Idle speed | 750 ± 50 rev/min |
| Bore | 80 mm (3.15 in) |
| Stroke | 82.8 mm (3.26 in) |
| Number of cylinders | 6 V-arrangement |
| Compression ratio | 10.5:1 |
| Ignition system | Siemens engine management system |
| Spark plugs | GSP 66527 |
| Spark plug gap | 1.0 mm ± 0.05 |
| CO ₂ emissions | 298 g/km |
| † Unleaded fuels of 95 - 98 RON can be used. | |

Engines

2.0 litre diesel

| | |
|---------------------------|---|
| Fuel | Diesel to EN 590 specification. CAUTION: This vehicle is NOT compatible with 'Bio-diesel' fuel. |
| Capacity | 1951 cm ³ |
| Firing order | 1-3-4-2 |
| Idle speed | 780 ± 50 rev/min |
| Bore | 84.0 mm |
| Stroke | 88.0 mm |
| Number of cylinders | 4 in-line |
| Compression ratio | 18.0:1 |
| CO ₂ emissions | |
| Manual | 205 g/km |
| Automatic | 240 g/km |

Electrical System

ELECTRICAL SYSTEM

| | |
|------------------------|---|
| Battery type: | |
| 1.8 Petrol engine | H5 sealed for life |
| 2.5 Petrol engine | H6 sealed for life |
| Diesel engine | H6 or H7, sealed for life, dependent on territory |
| Battery rating: | |
| 1.8 Petrol engine | 55 amp/hr |
| 2.5 Petrol engine | 75 amp/hr |
| Diesel engine | 75 amp/hr (H6), 80 amp/hr (H7) |
| | |
| Voltage and polarity | 12 V, negative (-) earth |

Steering

STEERING

| | |
|-----------------------------------|------------|
| Track: | |
| - Front | 1534 mm |
| - Rear | 1545 mm |
| Turning circle | 11.6 m |
| Steering wheel turns lock to lock | 3.16 |
| Wheel alignment: | |
| - Front (toe out) | -14' ± 15" |
| - Rear (toe in) | 20' ± 15" |

Wheels & Tyres

WHEELS & TYRES

WARNING

- **ALWAYS** use the same make and type of radial-ply tyres front and back. **DO NOT** use cross-ply tyres, or interchange tyres from front to back.
- For optimum performance and handling **ALWAYS** replace tyres with the same make and type as those fitted from new at the factory. If these tyres are not available, consult your Dealer/Authorised Repairer for advice on Land Rover approved alternatives. Failure to do so may adversely affect vehicle handling.
- **NEVER** drive your vehicle if the tyres are badly worn, cut or damaged, or if the pressures are incorrect.
- **Incorrectly inflated tyres wear rapidly and can seriously affect the vehicle's safety and road handling characteristics.**
- **Your vehicle is fitted with tubeless road wheels that will NOT accept inner tubes. DO NOT fit a tube tyre.**
- **ONLY Land Rover approved wheel and tyre combinations should be fitted to the vehicle.**

Wheel size and type

| Type | Size |
|-----------------------------------|-----------|
| Steel wheels | 5.5J x 15 |
| Alloy wheels: | |
| 15" wheels | 5.5J x 15 |
| 16" wheels | 6.0J x 16 |
| 17" wheels | 7.0J x 17 |
| 18" wheels | 7.0J x 18 |
| Road wheel nut torque | 115 Nm |
| Spare wheel nut torque to carrier | 45 Nm |

Tyre specification

| Wheel size | Tyre | Snow Chain Fitment | |
|--------------------------|------------------------------------|--------------------|------|
| | | Front | Rear |
| 5.5J x 15(steel & alloy) | 195/80 R15 'All Season' tyre | Y | Y |
| 6.0J x 16(alloy) | 215/65 R16 'Multi terrain' tyre | N | N |
| 7.0J x 17(alloy) | 225/55 R17 'Multi terrain' tyre | N | N |
| 7.0J x 18(alloy) | 235/50 R18 'All Season' tyre | N | N |

NOTE: For further information on Snow Chains, see 'SNOW CHAINS', page 189.

Tyre Pressures

TYRE PRESSURES

| | Tyre pressures - kPa (lbf/in ²) | |
|---|---|----------|
| All driving conditions (all tyre sizes) | Front & Rear | 211 (30) |

NOTE: Where a 195/80 R15 tyre on a steel rim is supplied for use as a temporary spare wheel, it should be inflated to the appropriate pressure shown in the above table.

See 'Temporary use spare wheel', page 202.

NOTE: A range of accessory wheels and tyres is available for your Land Rover Freelander. Consult your Land Rover Dealer/Authorised Repairer for a full description of all options.

Please note that this handbook does NOT list accessory tyres or accessory tyre pressures.

Accessory wheels - insert details

| Wheel size | Tyre | Snow Chain Fitment | |
|------------|------|--------------------|------|
| | | Front | Rear |
| | | | |

Accessory tyres - insert details

| Loading condition | | Tyre Pressure |
|--|-------|---------------|
| Normal operating conditions | Front | |
| | Rear | |
| Vehicle loaded to maximum gross vehicle weight | Front | |
| | Rear | |

Dimensions

DIMENSIONS - 3 & 5 DOOR

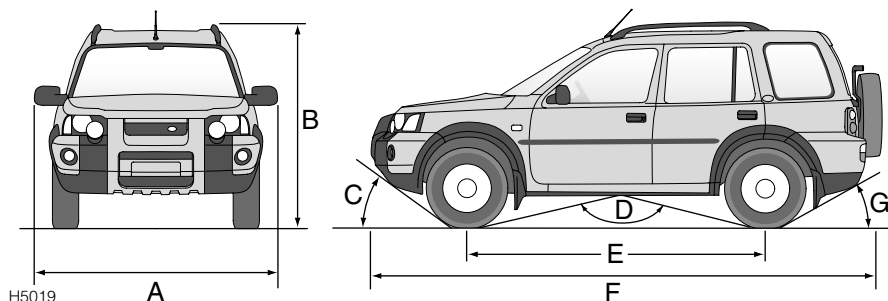

5-door model illustrated

| | | |
|---|---|------------------------|
| A | Overall width (inc. mirrors) | 2071 mm (6 ft 9.5 in) |
| B | Overall height† | |
| | - 3 door | 1709 mm (5 ft 7.3in) |
| | - 5 door | 1700 mm (5 ft 6.9 in) |
| B | Overall height† (inc. roof bars and cross rails): | |
| | - 3 door | 1800 mm (5 ft 10.9 in) |
| | - 5 door | 1820 mm (5 ft 11.7 in) |
| C | Max. approach angle† | 30.5° |
| D | Max. breakover angle | 156° |
| E | Wheelbase | 2557 mm (8 ft 4.7 in) |
| | Ground clearance (minimum)† | 186 mm (7.3 in) |
| | Wading depth (maximum) | 400 mm (15.7 in) |
| F | Overall length (inc. 195/80 spare wheel/tyre): | |
| | All models | 4423 mm (14 ft 6.1 in) |
| F | Overall length (inc. 215/65 spare wheel/tyre): | |
| | All models | 4437 mm (14 ft 6.7 in) |
| G | Max. departure angle (with towbar)† | 23.6° |
| G | Max. departure angle (without towbar)† | 33.9° |
| | † At EEC kerb weight | |

Dimensions

DIMENSIONS - 'SPORT' 3 & 5 DOOR

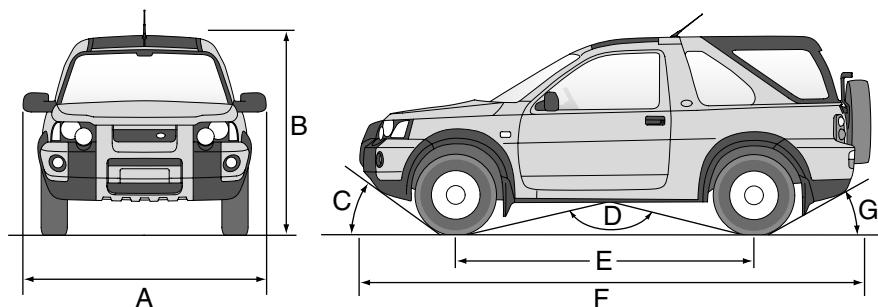

H5018

3-door model illustrated

| | | |
|---|---|--|
| A | Overall width (inc. mirrors) | 2071 mm (6 ft 9.5 in) |
| B | Overall height† - 3 door - 5 door | 1688 mm (5 ft 6.5 in) 1679 mm (5 ft 6.1 in) |
| B | Overall height† (inc. roof bars and cross rails): - 3 door - 5 door | 1779 mm (5 ft 10in) 1799 mm (5 ft 10.8 in) |
| C | Max. approach angle† | 29.4° |
| D | Max. breakover angle | 158° |
| E | Wheelbase | 2557 mm (8 ft 4.7 in) |
| | Ground clearance (minimum)† | 165 mm (6.5 in) |
| | Wading depth (maximum) | 400 mm (15.7 in) |
| F | Overall length (inc. 195/80 spare wheel/tyre): All models | 4432 mm (14 ft 6.1 in) |
| F | Overall length (inc. 215/65 spare wheel/tyre): All models | 4437 mm (14 ft 6.7 in) |
| G | Max. departure angle (with towbar)† | 23.1° |
| G | Max. departure angle (without towbar)† | 33.2° |
| | † At EEC kerb weight | |

Tow Bar Dimensions

TOW BAR DIMENSIONS

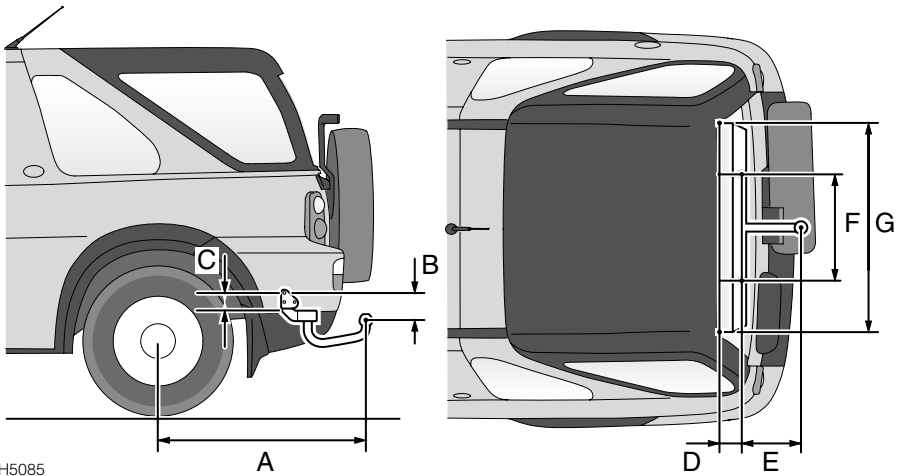

H5085

| | | |
|---|--|--------|
| A | Wheel centre to centre of towball | 892 mm |
| B | Centre of inner attachment points to centre of towball | 126 mm |
| C | Centre inner attachments to centre outer attachments | 79 mm |
| D | Centre inner attachments to centre outer attachments | 118 mm |
| E | Centre inner attachments to centre of towball | 265 mm |
| F | Distance between centres of inner attachments | 500 mm |
| G | Distance between centres of outer attachments | 990 mm |
| <i>Dimensions refer to towing equipment officially released by Land Rover</i> | | |

Vehicle Weights

VEHICLE WEIGHTS

| Approximate unladen vehicle weight (full fuel tank, excluding options): | |
|--|---------------------------------|
| Petrol models | 1427 - 1650 kg (3146 - 3638 lb) |
| Diesel models | 1555 - 1640 kg (3428 - 3616 lb) |
| Maximum gross vehicle weight: | |
| 1.8 Petrol models | 2040 kg (4497 lb)* |
| 2.5 Petrol models | 2060 kg (4542 lb)* |
| 2.0 Diesel models | 2080 kg (4586 lb)* |
| Maximum rear axle load: | |
| Petrol models | 1120 kg (2470 lb) |
| Diesel models | 1120 kg (2470 lb) |
| Maximum front axle load: | |
| 1.8 Petrol models | 1050 kg (2315 lb) |
| 2.5 Petrol models | 1080 kg (2381 lb) |
| 2.0 Diesel models | 1100 kg (2425 lb) |

NOTE: Axle weights are non additive; ie Maximum gross vehicle weight is not calculated by adding together maximum front and rear axle loads. The individual maximum axle weights and gross vehicle weight must not be exceeded.

***NOTE:** When towing, the gross vehicle weight can be increased by a maximum of 100 kg, provided road speed is limited to 100 km/h (60 mph).

Towing Weights

TOWING WEIGHTS

| MAXIMUM TRAILER WEIGHT. With vehicle loaded to gross vehicle weight (GVW). | | | |
|--|-------------------|------------------|---|
| | On-road | Off-road | Maximum Tow Hitch Load (Nose weight) |
| All engines | | | |
| Unbraked trailer | 750 kg (1653 lb) | 500 kg (1102 lb) | 140 kg (309 lb) |
| Trailer with over-run brakes | 2000 kg (4409 lb) | 500 kg (1102 lb) | 140 kg (309 lb) |
| To increase stability when loading to the maximum trailer weight, it is recommended that trailer load distribution be adjusted to achieve the maximum nose weight limit, see ' <i>ESSENTIAL TOWING CHECKS</i> ', page 151. | | | |
| NOTE: When towing on-road, DO NOT exceed 100 km/h (60 mph) | | | |

| GROSS TRAIN WEIGHT (WITH OVER-RUN BRAKES) = GVW plus maximum weight of trailer. | | | |
|--|-------------------|--|-----------------|
| Petrol engine 1.8 | 4040 kg (8907 lb) | | 140 kg (309 lb) |
| Petrol engine 2.5 | 4060 kg (8951 lb) | | 140 kg (309 lb) |
| Diesel engine 2.0 | 4080 kg (8995 lb) | | 140 kg (309 lb) |

| MAXIMUM ROOF RACK WEIGHT | | | |
|--|----------------|-----------------|--|
| | On-road | Off-road | |
| Land Rover approved system | 75 kg (165 lb) | 30 kg (66 lb) | |
| NOTE: The weight of Land Rover approved roof bars and cross rail roof rack is allowed for before further weight calculations are made. However, if an alternative roof rack system is to be used, the weight of the system must be included as part of the load weight. | | | |

Fuel Consumption

FUEL CONSUMPTION

The fuel consumption figures shown below have been calculated using a standard testing procedure (the new EC test procedure from Directive 93/116/EC), and produced in accordance with The Passenger Car Fuel Consumption (Amendment) Order 1996. Under normal use, a car's actual fuel consumption figures may differ from those achieved through the test procedure, depending on driving technique, road and traffic conditions, environmental factors, vehicle load and condition.

Fuel consumption figures

| | URBAN | | EXTRA-URBAN | | COMBINED | |
|----------------------|---------|------|-------------|------|----------|------|
| | l/100km | mpg | l/100km | mpg | l/100km | mpg |
| 1.8 Petrol manual | 13.6 | 20.8 | 8.5 | 33.3 | 10.4 | 27.3 |
| 2.5 Petrol automatic | 17.2 | 16.5 | 9.7 | 29.1 | 12.4 | 22.7 |
| 2.0 Diesel manual | 9.1 | 31.0 | 6.7 | 42.2 | 7.6 | 37.2 |
| 2.0 Diesel automatic | 11.3 | 25.2 | 7.1 | 39.6 | 8.6 | 32.8 |

Urban cycle

The urban test cycle is carried out from a cold start and consists of a series of accelerations, decelerations and periods of steady speed driving and engine idling. The maximum speed attained during the test is 50 km/h (31 mph) with an average speed of 19 km/h (12 mph).

Extra-urban cycle

The extra urban test cycle is carried out immediately after the urban test. Approximately half of the test comprises steady-speed driving, while the remainder consists of a series of accelerations, decelerations and engine idling. The maximum test speed is 120 km/h (75 mph) and the average speed 63 km/h (39 mph). The test is carried out over a distance of 7 km (4.3 miles).

Combined

The combined figure is an average of the urban and extra-urban test cycle results, which has been weighted to take account of the different distances covered during the two tests.

NOTE: These figures should not be compared with figures produced using the ECE/EEC procedure previously required by The Passenger Car Fuel Consumption Order 1983. Because of the changes in test procedure, even the urban figures would differ if the same car were subjected to both tests.

Appendices

DECLARATIONS OF CONFORMITY

IMPORTANT INFORMATION

The Declarations of Conformity detailed on the following pages are from manufacturers of RF (Radio Frequency) equipment, whose components are used in the manufacture of your Land Rover Freelander.

These manufacturers state that their components comply with relevant rules of the R & TTE (Radio and Telecommunication Terminal Equipment) directive.

The directive requires the manufacturer of short range radio devices to self certify that RF parts fitted to Land Rover vehicles are fit for use and that the declarations are supplied with the vehicle documentation. If at a future date a technical inspection is required, the declarations will provide all necessary information.

NOTE: *The Declarations of Conformity are published in the native language of the RF equipment manufacturer, in compliance with the R & TTE Directive.*

Appendices

DECLARATION OF CONFORMITY

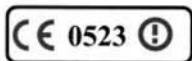

This declaration is the responsibility of the manufacturer / authorised representative within the Community:

TRW Automotive Electronics
45, College Road Perry Bar Birmingham, B44 8DU UNITED KINGDOM
(Name / Address)

This certifies that the following designated product

17TN&8RCv3
(Product identification)

complies with the essential protection requirements of R&TTE Directive 1999/5/EC on the approximation of the laws of the Member States relating to **Radio Spectrum Matters, EMC and Electrical Safety.**

This declaration applies to all specimens manufactured in accordance with the technical documentation described in the annex II. TRW Automotive Electronics keep this documentation at the proposal of the relevant national authorities of any Member State for inspection purpose. Assessment of compliance of the product with the requirements relating to the essential requirements acc. to Article 3 R&TTE was based on Annex IV of the Directive 1999/5/EC and the following standards:

Radio Spectrum: EN 300 220-1
(Identification of regulations / standards)

EMC: EN 300 683
(Identification of regulations / standards)

Safety: EN 60950 & ISO 3795 (based on FMVSS 302)
(Identification of regulations/ standards)

 The Transmitter 17TN and 8RCv3 are 433.92 MHz radio equipment not submitted to harmonised standards. This device is licence exempt and distributed in the European countries which will apply the R&TTE directive: Austria, Belgium, Denmark, Estonia, Finland, France, Germany, Greece, Iceland, Ireland, Italy, Luxembourg, Netherlands, Norway, Portugal, Spain, Sweden, Switzerland and UK.

(Place, date)

Birmingham, England

20/02/2001

(Signature)

JOHN BURGESS

Appendices

DECLARATION OF CONFORMITY

We, Dynex Semiconductor
Doddington Road
Lincoln
Lincolnshire
LN6 3LF
England

declare that the following Car Alarm Mass Movement Sensors:

DA5819-001, DA5819-002

meet the intent of the EMC Directive 89/336/EEC and the Low Voltage Directive 73/23/EEC.
Compliance was demonstrated by conformance to the following specifications, which have been listed in the Official Journal of the European Communities.

EMC (Requirements of ETS 30683)

Emissions

- a) EN 55022 Enclosure
- b) EN 55022/CISPR 16-1 DC power in/out

Immunity

- a) EN 6 1000-4-3 RF electro magnetic field (80 - 1000 MHz)
- b) EN 6 1000-4-2 Electrostatic discharge
- c) EN 61000-4-6 RF common mode (current clamp injection 0.15-80 MHz)
- d) ISO 7637 Parts 1 and 2 Transients and surges

SAFETY

EN 60950



MERVYN K. HOBDEN
Technology Leader — Sensor Products Group
Date: 21/02/01

Appendices



Connaught Electronics Ltd.

IDA INDUSTRIAL ESTATE,
DUNMORE ROAD, TUAM,
CO. GALWAY, IRELAND.

info@cel.ie www.cel-europe.com

Telephone: +353 93 25128
Fax: +353 93 25133
A/C Fax: +353 93 24047

1999/5/EC Declaration of Conformity

| | |
|-----------------------------|--|
| EC Directive: | 1999/5/EC |
| Manufacturer: | Connaught Electronics Ltd (CEL) IDA Industrial Estate Dunmore Road Tuam Co Galway Ireland |
| Apparatus: | <i>L20 Immobiliser</i> |
| Apparatus Class: | 2 |
| Radio Notified Body: | Motor Industry Research Association Watling Street Nuneaton Warwickshire, CV10 0TU |
| Radio Notified Body Number: | 0888 |
| Applicable Documents: | ETSI EN 300 330 (1999-05) CEPT ERC REC 70/03 Annex 9 95/56/EC 95/54/EC |

I certify that the *L20 Immobiliser* conforms with the essential requirements of the 1999/5/EC Directive as defined in article 3. This declaration of conformity has been issued under the sole responsibility of the manufacturer.











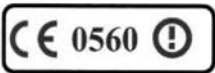











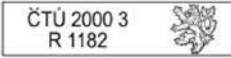

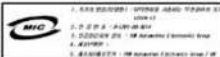
Signed on behalf of CEL by Paul Connors Team leader R&D

Paul Connors

Date: 10th July 2002

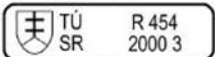
Appendices

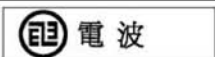
17TN/8RCv3 TYPE APPROVALS

| COUNTRY | | APPROVAL |
|---|---|---|
| Austria, Belgium, Denmark, Estonia, Finland, France, Germany, Greece, Iceland, Ireland, Italy, Luxembourg, Netherlands, Norway, Portugal, Spain, Sweden, Switzerland, Tahiti and UK | |  |
| Canada (Tx) |  | 19841021576 |
| Canada (Rx) |  | 35821032194A |
| Cyprus |  | MCW 129/954/1998 |
| Gibraltar |  | Yes |
| Malta | | WT/962/9211 |
| New Zealand |  | Yes |
| South Africa |  | RX-387/98 |
| USA |  | KHH17TN |
| Brazil |   | 108200-ASP1194 |
| Croatia (Tx) |  | SRD-144/00 |
| Croatia (Rx) |  | SRD-145/00 |
| Czech Republic |  |  |
| Korea |  |  |
| Latvia |  | 313R |
| Lithuania |  | 0261 |
| Poland |   | ML S.H.Nr1155/2000 |
| Saudi Arabia |  | TRW 17TN/8RCv3 made in UK 433.92 MHz, 3V lithium battery SASO 1322/1997 |
| Slovakia |  |  |
| Slovenia |  | C231—1603/00 |
| Taiwan |  |  |
| Tunisia |  | 0292/MAT/2000 |
| Uruguay |  | 059/DFR/2000 |

Index

A

| | |
|---------------------------|--------|
| Accessories | 197 |
| Aerial | 91 |
| Air blower control | 12, 77 |
| Air conditioning | 12, 77 |
| maintenance | 80 |
| operation | 80 |
| Air distribution control | 12, 77 |
| Air recirculation control | 12, 77 |
| Air temperature control | 12, 77 |
| Air vents | 79 |
| Airbag SRS | |
| cleaning | 194 |
| disposal | 50 |
| location | 47 |
| operation | 48 |
| precautions | 47 |
| servicing | 50 |
| warning light | 49 |
| Alarm | 26 |
| Alarm indicator light | 29 |
| Anti-freeze | 177 |
| Anti-lock braking (ABS) | 120 |
| Ashtray | 86 |
| Audio equipment | 91 |
| Audio system | 91 |
| Automatic transmission | 108 |
| Auxiliary power socket | 87 |

B

| | |
|------------------------|----------|
| Battery | |
| charging | 185 |
| disposal | 184 |
| maintenance | 183 |
| remove & replace | 184 |
| specification | 238 |
| Block heaters | 96, 98 |
| Bonnet | 171 |
| Booster cables | 207 |
| Brake fluid | |
| check & top-up | 178 |
| Brakes | |
| anti-lock brakes (ABS) | 120 |
| brake pads | 118 |
| foot brake | 118 |
| handbrake | 119 |
| servo assistance | 118 |
| warning light | 118, 121 |

| | |
|--------------------|-----|
| Breakdown recovery | 210 |
| Bulb replacement | 217 |
| front fog lights | 223 |

C

| | |
|----------------------------|----------|
| Capacities | 235 |
| Catalytic converter | 101 |
| CD autochanger* | 91, 157 |
| Child safety seats | 45 |
| Child-proof door locks | 32 |
| Cigar lighter | 86 |
| Cleaning (exterior) | 190 |
| Cleaning (interior) | 193 |
| Clock | 82 |
| Cold climates | 96, 98 |
| CommandShift, transmission | 108 |
| Controls | |
| centre console | 10, 11 |
| fascia | 5, 24 |
| instrument panel | 6 |
| Coolant | |
| check & top-up | 176 |
| replacement | 167 |
| specification | 177 |
| Cooling system | 176 |
| Courtesy lights | |
| bulb replacement | 226, 227 |
| operation | 81 |
| Cross rails (roof rack) | 148 |
| Cruise control | 116 |
| Cup holders | 84 |

D

| | |
|-----------------------------|----------|
| Data | 236 |
| Defrosting | 78 |
| Demisting | 78 |
| Digital display | 53 |
| Dimensions | 242, 243 |
| Dipstick | 175 |
| Direction indicators | |
| bulb replacement (front) | 221 |
| bulb replacement (rear) | 224 |
| operation | 58 |
| Distance recorder | 53 |
| Door handles (interior) | 31 |
| Door locking cut-off switch | 33 |
| Door mirrors | 65 |
| Door sill locking buttons | 31 |
| Drinks stowage | 83, 84 |

Index

| | | | |
|--|--------------|------------------------------|---------------|
| Driver's storage | 83 | Fuse box (supplementary) | 216 |
| Driving | 98, 101, 111 | Fuses | 211 |
| E | | G | |
| Electronic traction control | 122 | Gauges | |
| Emergency starting | 207 | fuel | 53 |
| Emergency towing | 209 | speedometer | 52 |
| Emission control system | 100, 170 | tachometer | 52 |
| Engine | | temperature | 52 |
| compartment (diesel) | 172 | Gearbox (automatic) | 108 |
| compartment (petrol) | 173, 174 | automatically selected modes | 112 |
| fuse box | 215 | display | 53 |
| oil check & top-up | 175 | 'kick-down' | 112 |
| specifications | 236 | lever positions | 109 |
| starting (diesel) | 97 | selector release button | 108 |
| starting (petrol) | 96 | sport mode | 110 |
| warming-up | 99 | starting | 111 |
| Engine immobilisation | 32 | Gearbox (manual) | 107 |
| Engine oil | | General data | 233 |
| disposal (used oil) | 169 | Glovebox | 82 |
| Exterior mirrors | 65 | Glovebox light | |
| F | | bulb replacement | 228 |
| Face level vents | 79 | operation | 82 |
| Fascia | 5, 24 | Ground clearance | 157, 242, 243 |
| Fluid specifications | 233 | H | |
| Fog lights (front) | | Handbrake | 119 |
| bulb replacement | 223 | Handset | |
| operation | 60 | battery replacement | 34 |
| Fog lights (rear) | | operation | 27 |
| bulb replacement | 222 | replacement | 23 |
| operation | 60 | resynchronise | 34 |
| Foot brake | 118 | Hardback | |
| Fresh air vents | 79 | cleaning | 191 |
| Front door - passenger's window switch | 69 | fitting and removal | 138 |
| Fuel | | Hazard warning lights | 60 |
| cut-off switch (petrol) | 106 | Head restraints | 36 |
| economy | 99 | Headlights | 58 |
| empty tank | 105 | bulb replacement | 218, 219 |
| filling | 104 | levelling | 59 |
| filling difficulties | 105 | main beam | 59 |
| gauge | 53 | operation | 8, 58 |
| priming (diesel) | 105 | Heated front screen* | 76 |
| safety | 104 | Heated front seats* | 12, 37, 76 |
| specification | 103 | Heated rear screen | 12 |
| tank capacity | 235 | Heated rear window | 76 |
| Fuel burning heater* | 79 | Heated seats | 37 |
| Fuel consumption | 247 | | |

Index

| | | | |
|--|----------|--|--|
| Heater | | | |
| Fuel burning* | 79 | | |
| PTC | 79 | | |
| Heater controls | 12, 76 | | |
| Heating | 78 | | |
| High mounted stop light | | | |
| bulb replacement | 225 | | |
| Hill descent control (HDC) | 113 | | |
| Horn | 64 | | |
| I | | | |
| Ignition switch | 95 | | |
| Immobilisation | 32 | | |
| Indicators | | | |
| bulb replacement | 221 | | |
| operation | 58 | | |
| Inertia switch | 33, 106 | | |
| Instrument illumination control | 54 | | |
| Instrument panel | | | |
| digital display | 53 | | |
| instruments | 52 | | |
| warning lights | 55 | | |
| Interior (cleaning) | 193 | | |
| Interior lights | | | |
| bulb replacement | 226, 227 | | |
| operation | 81 | | |
| Interior mirror | 66 | | |
| Interior space protection | 31 | | |
| J | | | |
| Jacking the vehicle | 204 | | |
| Jump leads | 207 | | |
| K | | | |
| Key replacement | 23 | | |
| Kick-down | 112 | | |
| L | | | |
| Lashing rings | 210 | | |
| Leather cleaning | 193 | | |
| Lights (exterior) | | | |
| direction indicators | 58 | | |
| side, tail, headlights | 8, 58 | | |
| Lights (interior) | | | |
| courtesy | 81 | | |
| map-reading | 81 | | |
| Load carrying | | | |
| loading weights | 147 | | |
| lockable stowage box | 146 | | |
| long loads | 38 | | |
| luggage anchor points | 146 | | |
| luggage space (maximum) | 39 | | |
| rear seat folding | 38 | | |
| roof rack | 147 | | |
| Loadspace cover | 89 | | |
| Loadspace light | | | |
| bulb replacement | 228 | | |
| operation | 81 | | |
| Locking | 26 | | |
| Locking switch (interior) | 30 | | |
| Locking wheel nuts | 203 | | |
| Low-fuel warning light | 53 | | |
| Lubricant specifications | 233 | | |
| Luggage anchor points | 146 | | |
| Luggage area | 146 | | |
| M | | | |
| Maintenance | 167, 168 | | |
| Manual transmission | 107 | | |
| Map reading lights | | | |
| bulb replacement | 226 | | |
| operation | 81 | | |
| Mileometer | 53 | | |
| Mirrors (exterior) | | | |
| adjustment | 65 | | |
| folding | 65 | | |
| Mirrors (interior) | 66 | | |
| Mislock | 28 | | |
| Mobile phones | 90 | | |
| N | | | |
| Number plate lights (bulb replacement) | 225 | | |
| O | | | |
| Odometer | 53 | | |
| Off-road driving | 121, 155 | | |
| Oil (engine) | | | |
| check & top-up | 175 | | |
| disposal | 169 | | |
| specification | 175 | | |
| Over-temperature warning light | 52 | | |
| Owner maintenance | 168 | | |

Index

| | | | |
|---------------------------------------|-----|--|----------|
| P | | | |
| Parking | 99 | Screen wash | 181 |
| Parking aid system | 123 | Seat belt | |
| Particle filter* | 75 | adjustment | 42 |
| Parts & accessories | 197 | care | 44 |
| Poisonous fluids | 169 | operation | 41 |
| Polishing (bodywork) | 192 | presenter | 42 |
| Power socket | 87 | pre-tensioners | 43 |
| Power steering top-up | 180 | safety | 40 |
| Pre-tensioners | 43 | testing | 44 |
| Pre-tensioners | | Seat belt pretensioners | |
| servicing | 44 | servicing | 44 |
| PTC Heater | 79 | Seat heaters | 37 |
| Punctured tyres | 188 | Seats | |
| | | child safety seats | 45 |
| R | | front | 35 |
| Radio/cassette player | 91 | front - backrest release | 36 |
| aerial | 91 | heated | 37 |
| display | 82 | rear - folding | 38 |
| remote controls | 91 | Security box | 146 |
| Reading lights | 81 | Security card | 19 |
| Rear door | 88 | Selector lever | 108 |
| Rear door - passenger's window switch | 69 | Service portfolio book | 19, 167 |
| Rear fog guard lights | | Servicing | 167, 168 |
| bulb replacement | 222 | Servo assistance | 118 |
| operation | 60 | Sidelights | |
| Rear lights (bulb replacement) | 222 | bulb replacement | 220 |
| Rear screen - operation | 71 | operation | 8, 58 |
| Rear screen demister | 12 | Side-repeater light (bulb replacement) | 222 |
| Rear seats | 38 | Single point entry | 29 |
| Rear window isolation switch | 69 | Snow chains | 189 |
| Rearscreen washers | 63 | Softback | |
| Rearscreen wipers | 63 | cleaning | 191 |
| Rear-view mirror | 66 | folding | 127 |
| Recovery (of vehicle) | 209 | unfolding | 133 |
| Remote audio controls | 91 | Spare wheel | |
| Remote handset battery | 34 | refitting | 203 |
| Reverse lights (bulb replacement) | 222 | removing | 202 |
| Road testing on dynamometers | 170 | Speedometer | 52 |
| Roof bars | | Sport mode | 110 |
| fitting | 143 | Starter switch | 95 |
| removal | 142 | Starting | |
| Roof rack | 147 | automatic models | 111 |
| cross rails | 148 | diesel models | 97, 101 |
| Running-in | 99 | emergency | 207 |
| | | petrol models | 96, 101 |
| S | | Steering column | |
| Safety in the garage | 169 | adjustment | 51 |
| Safety on the forecourt | 104 | lock | 26 |

Index

| | | | |
|--------------------------------|----------|----------------------------------|--------|
| Stop lights (bulb replacement) | 224 | V | |
| Stowage box | 146 | Vanity mirror | 67 |
| Sun visor | 85 | Vanity mirror (bulb replacement) | 229 |
| Sunglasses pocket | 85 | Vehicle identification number | 196 |
| Sunroof | 73 | Ventilation | 75, 79 |
| Superlocking | 28 | | |
| T | | W | |
| Tachometer | 52 | Wading | 163 |
| Tail lights | | Warning lights | 55 |
| bulb replacement | 224 | ABS | 56 |
| operation | 8, 58 | Airbag SRS | 57 |
| Taildoor | | Battery charging | 57 |
| operation | 145 | Cruise control | 55 |
| Taildoor glass | | Direction indicators | 55 |
| operation | 71 | Door open | 56 |
| recalibration | 72 | Engine malfunction (diesel) | 57 |
| Targa roof | 125 | Engine malfunction (petrol) | 55 |
| T-bar - removal | 126 | Glow plugs | 57 |
| Technical data | 233, 236 | Handbrake & brake system | 56 |
| Telephones | 90 | HDC 'failure' | 56 |
| Temperature display units | 53 | HDC 'information' | 56 |
| Temperature gauge | 52 | Headlight main beam | 55 |
| Temporary use spare wheel | 202 | Low oil pressure | 57 |
| Tool kit | 201 | Overspeed | 57 |
| Tow bars | 151 | overview | 7 |
| Towing eyes | 209 | Seat belt | 57 |
| Towing for recovery | 210 | Traction control | 56 |
| Towing on severe inclines | 150 | Trailer direction indicators | 57 |
| Towing precautions | 149 | Warnings (in handbook) | 19 |
| Towing weights | 246 | Washer fluid | 181 |
| Traction control | 122 | Washer jets | 181 |
| Trailer electrical socket | 151 | Washers (windscreen) | |
| Transporter or trailer lashing | 210 | operation | 9 |
| Trip recorder | | Washing (the bodywork) | 190 |
| display | 53 | Weights | 245 |
| reset button | 52 | Wheel changing | |
| Tyre | | jacking | 204 |
| pressures | 187 | locking wheel nuts | 203 |
| punctures | 188 | spare wheel | 202 |
| replacement | 189 | tools | 201 |
| specifications | 240 | wheel removal | 206 |
| wear indicators | 188 | Wheel sizes | 240 |
| Tyre pressures | 241 | Windows | |
| U | | 'one touch' down (driver's) | 69, 70 |
| Unlocking | 29 | operation | 68 |
| | | rear ventilators (3-door) | 72 |
| | | taildoor | 71 |

Index

| | |
|-------------------------|-------|
| Windscreen washers | |
| fluid top-up | 181 |
| operation | 9, 62 |
| Windscreen wipers | |
| operation | 9, 61 |
| variable delay | 9, 62 |
| wiper blade replacement | 182 |